

LOUISIANA DEPARTMENT OF EDUCATION

**BULLETIN 119 SUPPLEMENT, VOLUME I:
LOUISIANA SCHOOL BUS REGULATIONS,
SPECIFICATIONS, AND INSPECTIONS**

2019 Edition

Adopted by:

The Louisiana Department of Education
Healthy Communities Section
Claiborne Building, 1201 North Third Street
Baton Rouge, LA 70802





CONTENTS

FOREWORD.....	6	BRAKES: AIR	16
ABOUT THIS DOCUMENT.....	7	BUMPER: FRONT	17
GUIDING PRINCIPLES	7	BUMPER: REAR.....	17
INTENDED USE.....	7	CERTIFICATION.....	17
INTERPRETATIONS AND INFORMATION, INTERIM INQUIRIES AND AMENDMENT REQUESTS.....	8	COLOR.....	18
MISCELLANEOUS TRANSPORTATION EQUIPMENT REGULATIONS.....	9	COMMUNICATIONS SYSTEMS.....	18
GENERAL INFORMATION.....	9	CONSTRUCTION.....	18
SCHOOL BUS PURCHASES.....	9	CROSSING CONTROL ARM (crossing gate).....	19
SALES TAX EXCLUSION FOR SCHOOL BUS PURCHASES BY INDEPENDENT OPERATORS.....	10	DEFROSTERS.....	19
FROZEN MILEAGE FOR OWNER/OPERATORS.....	10	DOORS.....	19
SCHOOL BUS INSURANCE	11	DRIVE SHAFT	20
SCHOOL BUS LEASES.....	11	ELECTRICAL SYSTEM.....	20
MEASURING SCHOOL BUS BODIES TO DETERMINE OPERATORS' COMPENSATION.....	11	ELECTRONIC STABILITY CONTROL (ESC).....	22
SCHOOL BUS REPAIRS AND MAINTENANCE	11	EMERGENCY EQUIPMENT.....	23
SCHOOL BUSES SOLD FOR NON-SCHOOL TRANSPORTATION PURPOSES.....	11	EMERGENCY EXITS.....	24
CALCULATING THE AGES OF SCHOOL BUSES	12	EXHAUST SYSTEM.....	25
CALCULATING THE AGES OF SCHOOL BUSES BY MODEL YEAR.....	12	FENDERS: FRONT	25
SCHOOL BUS BODY AND CHASSIS SPECIFICATIONS...13		FIRE SUPPRESSION SYSTEMS (OPTIONAL).....	25
INTRODUCTION TO SCHOOL BUS SPECIFICATIONS....13		FLOORS	25
RESPONSIBILITY FOR COMPLIANCE.....	13	FRAME	26
SCHOOL BUS TYPES	14	FUEL SYSTEM	26
BUS BODY AND CHASSIS SPECIFICATIONS.....	15	GOVERNOR.....	26
GENERAL REQUIREMENTS	15	HANDRAILS.....	26
AIR CLEANER.....	15	HEATING SYSTEM, PROVISION FOR.....	27
AISLE	15	HEATING AND AIR CONDITIONING SYSTEMS	27
AXLES.....	15	HINGES	29
BACK-UP WARNING ALARM.....	16	HORN	29
BRAKES: GENERAL	16	IDENTIFICATION	30
BRAKES: HYDRAULIC.....	16	INSIDE HEIGHT	30
		INSTRUMENTS AND INSTRUMENT PANEL.....	31
		INSULATION (OPTIONAL).....	31
		INTERIOR	32

LAMPS AND SIGNALS	32	UNDERCOATING	41
METAL TREATMENT	34	VENTILATION.....	41
MIRRORS.....	34	WHEELHOUSING.....	41
MOUNTING.....	34	WINDOWS.....	42
MUD GUARDS (MUD FLAPS)	34	WINDSHIELD WASHERS	42
OIL FILTER.....	34	WINDSHIELD WIPERS	42
OPENINGS.....	35	SPECIALLY EQUIPPED SCHOOL BUS SPECIFICATIONS.....	43
OVERALL LENGTH	35	INTRODUCTION.....	43
OVERALL WIDTH.....	35	DEFINITION.....	43
PASSENGER LOAD	35	GENERAL REQUIREMENTS.....	43
PUBLIC ADDRESS SYSTEM (OPTIONAL)	35	AISLES.....	43
RETARDER SYSTEM (OPTIONAL EQUIPMENT).....	35	COMMUNICATION SYSTEM	43
RETROREFLECTIVE MATERIAL	35	FIRE SUPPRESSION SYSTEM (OPTIONAL).....	43
ROAD SPEED CONTROL.....	36	GLAZING.....	43
RUB RAILS.....	36	IDENTIFICATION	44
SEATS AND RESTRAINING BARRIERS.....	36	PASSENGER CAPACITY RATING.....	44
SHOCK ABSORBERS.....	37	POWER LIFTS	44
SIDE SKIRTS	38	REGULAR SERVICE ENTRANCE.....	45
STEERING GEAR.....	38	RESTRAINING DEVICES	46
STEPS	38	SEATING ARRANGEMENTS.....	46
STEP TREADS.....	38	SECUREMENT AND RESTRAINT SYSTEM FOR WHEELCHAIRS AND WHEELCHAIR-SEATED OCCUPANTS	46
STIRRUP STEPS	39	SPECIAL LIGHT	47
STOP SIGNAL ARM	39	SPECIAL SERVICE ENTRANCE	47
STORAGE COMPARTMENT (OPTIONAL).....	39	SPECIAL SERVICE ENTRANCE DOORS	47
SUN SHIELD	39	SUPPORT EQUIPMENT AND ACCESSORIES	48
SUSPENSION SYSTEMS.....	39	TECHNOLOGY AND EQUIPMENT, NEW.....	49
THROTTLE.....	39	SCHOOL BUS INSPECTION PROGRAM	50
TIRES AND RIMS	39	LOUISIANA SCHOOL BUS INSPECTION PROGRAM	50
TOWING ATTACHMENT POINTS	40	INITIAL AND SEMI-ANNUAL SCHOOL BUS INSPECTIONS	50
TRACTION ASSISTING DEVICES (OPTIONAL).....	40	INSPECTION PROCEDURE.....	50
TRANSMISSION	40	OUT-OF-SERVICE CRITERIA.....	50
TRASH CONTAINER AND HOLDING DEVICE (OPTIONAL).....	41	RESOURCE INFORMATION.....	51
TURNING RADIUS.....	41		

SCHOOL BUS RECOMMENDED OUT-OF-SERVICE CRITERIA	51	EXHAUST SYSTEM.....	67
BACKING ALARM	51	FUEL SYSTEM	67
BODY EXTERIOR.....	51	LAMPS/SIGNALS.....	67
BODY INTERIOR.....	51	MIRRORS.....	68
BRAKE SYSTEM(S)	52	STEERING SYSTEM.....	68
CROSSING CONTROL ARM (CROSSING GATE).....	53	SUSPENSION COMPONENTS	70
DIFFERENTIAL.....	53	TIRES/WHEELS/HUBS	71
DRIVESHAFT	53	WHEELCHAIR LIFT-EQUIPPED VEHICLES.....	73
ELECTRICAL/BATTERY	54	WINDOWS.....	73
EMERGENCY EQUIPMENT.....	54	ALTERNATIVE FUELS	74
EMERGENCY EXITS.....	54	INTRODUCTION.....	74
ENGINE	55	GENERAL REQUIREMENTS.....	74
EXHAUST SYSTEM.....	55	EQUIPMENT FOR TRANSPORTATION OF THE TRANSPORTATION OF INFANTS, TODDLERS AND PRE- SCHOOL CHILDREN.....	76
FUEL SYSTEM	55	APPENDIX A: TERMS AND DEFINITIONS	80
LAMPS/SIGNALS.....	55	INTRODUCTION.....	80
MIRRORS (571.111)	56	TERMS AND DEFINITIONS.....	80
STEERING SYSTEM.....	56	APPENDIX B: Supplements to School Bus Body and Chassis Specifications	110
SUSPENSION COMPONENTS.....	57	NATIONAL SCHOOL BUS YELLOW STANDARD.....	110
TIRES/WHEELS/HUBS	58	S1: SCOPE	110
WHEELCHAIR LIFT-EQUIPPED VEHICLES.....	59	S2: PURPOSE.....	110
WINDOWS.....	59	S3: APPLICATION.....	110
RECOMMENDED SCHOOL BUS INSPECTION PROCEDURES.....	60	S4: COLOR DEFINITION	110
BACKING ALARM	60	COLORIMETRIC (CIE) DATA, C/10°	110
BODY EXTERIOR.....	60	S5: REQUIREMENTS.....	110
BODY INTERIOR.....	60	S6: COLOR MATCHING	110
Nut and String Test.....	61	BUS BODY HEATING SYSTEM TEST.....	111
BRAKE SYSTEMS.....	62	Computational Chart 6.1 (Fahrenheit).....	116
DIFFERENTIAL.....	65	Computational Chart 6.1 Optional Measurements (Fahrenheit).....	117
DRIVESHAFT	65	Computational Chart 6.2 (Celsius).....	118
ELECTRICAL/BATTERY	66	Chart 6.2 Optional Measurements (Celcius)	119
EMERGENCY EQUIPMENT.....	66	RETROREFLECTIVE SHEETING DAYTIME COLOR SPECIFICATION	120
EMERGENCY EXITS.....	66		
ENGINE	67		

PLACEMENT OF REFLECTIVE MARKINGS AND WHITE ROOF..... 121

PLACEMENT OF RETROREFLECTIVE MARKINGS122

NOISE TEST PROCEDURE123

SCHOOL BUS SEAT UPHOLSTERY FIRE BLOCK TEST 124

APPENDIX C: Bibliography for Alternative Fuels127

BIBLIOGRAPHY127

APPENDIX D: Sample Procedures and Forms 128

(SAMPLE).....129

FOREWORD

Acting under the authority granted by the Louisiana Legislature (R.S. 17:164 et seq.), the Louisiana Department of Education (LDE) has developed, revised and promulgated school transportation-related specifications and procedures for decades. The specifications and procedures were published in LDOE Bulletins 1191, 1213, 1475 and 1886, and from time to time, they were updated to include changes in vehicle specifications, operational requirements and best practices. In 2007, the LDOE consolidated the four bulletins into one document entitled Bulletin 119, *Louisiana School Transportation Specifications and Procedures*.

The title for Bulletin 119 no doubt was derived from the statutory requirement that “the Louisiana Board of Education (i.e., BESE) is authorized, directed and empowered to establish and adopt regulations relating to the construction, design, equipment and operation of school busses used in transportation of students to and from school” (R.S. 17:164). The statute further references standards of the National Congress on School Transportation (NCST) (previously known as the National Conference on School Transportation) as the primary source of Louisiana school bus specifications. The NCST publication of school bus and related equipment standards is entitled the *National School Transportation Specifications and Procedures*.

Bulletin 119 was intended to include only specific regulatory requirements; however, a blend of regulations and operational procedures were published in the original document. Meanwhile, regulations have been added, rescinded or revised, and constantly requesting the Board of Elementary and Secondary Education to adopt revisions to Bulletin 119 may result in delays in disseminating vital information to LEAs, private transportation companies, school bus manufacturers and other entities that rely on current school transportation information.

With approval of, and adoption by, the Board of Elementary and Secondary Education, the title of Bulletin 119 has been changed from *Louisiana School Transportation Specifications and Procedures* to *Louisiana Student Transportation Regulations*. As described below, two supplementary documents issued by the Louisiana Department of Education combine to provide detailed information regarding school bus and related equipment regulations, specifications, inspections and operational procedures.

Supplement to Bulletin 119, Vol. I: *Louisiana School Bus Regulations, Specifications and Inspections* includes regulations pertaining to new and pre-owned school bus purchases, school bus disposal requirements, NCST specifications with revisions to incorporate Louisiana-specific requirements or preferences and NCST-recommended inspection procedures. Contents of Vol. I are authorized by Louisiana Revised Statutes 17:158.5, et seq and by the Louisiana Board of Elementary and Secondary Education as published in Bulletin 119.

Supplement to Bulletin 119, Vol. II: *Louisiana Student Transportation Operational Procedures* includes Louisiana vehicle operational regulations, pre-employment screening and continued employment requirements for school bus operators and bus attendants, student safety issues, routing and bus stop design and implementation and other operational topics.

ABOUT THIS DOCUMENT

Louisiana School Bus Regulations, Specifications and Inspections consists of the following distinct sections and related appendices: “Miscellaneous Transportation Equipment Bus Regulations,” “School Bus Body and Chassis Specifications,” “Specially Equipped School Bus Specifications,” “School Bus Inspections,” “Alternative Fuels” and “Equipment for the Transportation of Infants, Toddlers and Pre-School Children.” Additional information for specific topics can be found in the appendices.

The document is a “living document,” and, as such, it is designed to provide timely, clear instructions to school bus owners, manufacturers and vendors, inspectors and service personnel regarding Louisiana’s school bus purchase procedures, adopted specifications for school buses and related equipment and for standards and procedures to be incorporated in vehicle and related equipment inspections, replacements and repairs.

Louisiana statutes address specific aspects of school bus acquisition, ownership, vehicle specifications, inspections and operations and various other school transportation-related topics. Additionally, statutes authorize and direct the Louisiana Board of Elementary and Secondary Education (BESE) and the Louisiana Department of Education to oversee school transportation activities in Louisiana. BESE Bulletin 119, as well as its companion Supplements I and II, provide comprehensive descriptions and legal descriptions for all phases of school transportation for use by all parties who share interest and responsibility for compliance with the statutes, regulations and procedures.

With respect to specifications for school buses and related equipment, after each National Congress on School Transportation publishes its adopted changes in the *National School Transportation Specifications and Procedures* (available at ncstonline.org) or distributes interim addenda to that document, the Louisiana Department of Education will activate a process for reviewing the recommendations and will cause the *Louisiana School Bus Regulations, Specifications and Inspections* to be revised accordingly.

Revisions in Louisiana statutes and/or Department of Education regulations will be published as amendments to this document. Compliance shall become effective as stated at the time of publication, or as otherwise specified by statute or another official document.

GUIDING PRINCIPLES

- A. Information published in this document is intended to keep interested parties apprised of statutory requirements and other regulations that apply to various conditions of purchase, ownership, maintenance, inspection and disposal of school buses and related equipment.
- B. The overriding principle for Louisiana’s adoption of the National Congress on School Transportation’s revised *National School Transportation Specifications and Procedures* is to provide the safest modes of transportation to and from school and school-related activities for the school children of Louisiana.
- C. Specifications for school buses and related equipment are adopted so as to promote competition among manufacturers to design and construct equipment that is both reliable and affordable to school districts, owner/operators and independent transportation contractors.
- D. Louisiana’s specifications for school buses and related equipment are designed to allow for approval of the use of new inventions and improvements that are consistent with FMVSSs, Louisiana statutes and goals of safety, security and efficiency and that have been approved by the Louisiana Department of Education.

INTENDED USE

The Louisiana Legislature has “directed and empowered” the Louisiana Board of (Elementary and Secondary) Education “to establish and adopt regulations relating to the construction, design, equipment and operation of school busses (sic) used in transportation of students to and from school” (R.S. 17:164 et seq.). The specifications, regulations and procedures described in this

document, therefore, are intended for use by school districts, charter schools, Head Start grantees and other entities that have been placed under the jurisdiction of the Department of Education, including private companies that contract with LEAs to provide school transportation services, and for use for manufacturers, vendors, inspectors and technicians that have specific interests in school transportation services. The document is made available, also, as a guide for non-public schools to consider when establishing their respective regulations, specifications and inspections.

The following terms are used throughout this document to define the applicability of Louisiana’s specifications and inspection procedures for schools, school districts and private contractors:

- A. **SHALL**: a mandatory condition. Where certain school bus designs, equipment or operations are described with the shall stipulation, it is mandatory that all school buses and all school bus-related operations meet those requirements, as written.
Note: The word shall is used also when referring to items that are already adopted into federal or state laws, standards or regulations.
- B. **SHOULD**: an advisory condition. Where certain school bus designs, equipment or operations are described with the word should, such items are considered to be advisable usage. In other words, the item is recommended, but not mandatory, for all school buses or all school bus-related operations.
- C. **MAY**: a permissive condition. Where certain school bus designs, equipment or related operations are described with the word may, such items are considered for possible usage. However, there is no intent that the item be required for all school buses or all school bus-related operations.

LEAs are required to provide employees, private contractors, vendors of school buses, parts and supplies, motor vehicle inspectors, repair shops and school bus driver instructors with specifications and procedures that apply to their respective roles in the student transportation system and to supplement the contents of this document with applicable local policies and procedures.

The vehicle specifications contained herein, **unless otherwise described**, are intended to apply primarily to **new** vehicles, including all types of school buses, as defined in APPENDIX A: GLOSSARY OF TERMS AND DEFINITIONS, under *Bus, School Bus*, which lists the various types of “school buses.” **It should be noted that vehicles with a capacity of ten (10) or fewer persons, including the driver, cannot be certified as school buses under federal regulations.**

Effective dates of specifications are determined by effective dates of FMVSSs, dates of adoption of the *National School Transportation Specifications and Procedures* by the NCST, published effective dates of new or revised Louisiana statutes or regulations or procedures adopted by the Louisiana Department of Motor Vehicles or the Louisiana Department of Education. **Interested parties, therefore, are responsible for keeping abreast of any changes that may affect them in their respective roles with respect to manufacture, acquisition, sales, maintenance and repair, inspection or operation of school buses and related equipment for use in school transportation activities in Louisiana schools.**

The Louisiana Department of Education ad hoc Specifications Committee agreed that this document should not include only Louisiana-specific items, but should include all applicable specifications for Louisiana school buses and related equipment. Minor variations in specifications can easily be overlooked (e.g., *shall* in the NCST specifications but *should* in LA specifications or vice versa; items included in NCST specifications but omitted in LA specifications or vice versa). **When examining this document, therefore, the reader is advised to have available the applicable edition of the NCST Specifications and Procedures for comparison.**

INTERPRETATIONS AND INFORMATION, INTERIM INQUIRIES AND AMENDMENT REQUESTS

Requests for interpretation of the 2019 regulations, specifications and inspection procedures document, interim inquiries and/or amendment requests shall be sent to the Louisiana Department of Education, Healthy Communities Section, Claiborne Building, 1201 N. Third Street, Baton Rouge, LA 70802, attention Mr. Michael Comeaux, or to michael.comeaux@la.gov.

MISCELLANEOUS TRANSPORTATION EQUIPMENT REGULATIONS

GENERAL INFORMATION

Louisiana statutes and Department of Education policies and procedures address specific transportation equipment topics besides specifications for new buses and school bus inspections. This section describes Louisiana-specific regulations and procedures pertaining to the acquisition and disposal of school buses.

SCHOOL BUS PURCHASES

- A. No vehicle with rated capacity of more than 10 passengers shall be classified as a school bus and thereby used to transport students to and from school and school-related activities unless said vehicle originally was manufactured and certified as a school bus and maintained the certification as a school bus throughout the life of the vehicle, all in accordance with federal and state requirements.
- B. LEAs are authorized to voluntarily pool bids for school bus purchases for economical acquisition of school buses and related equipment and supplies (R.S. 17:158.3).
- C. Any pre-owned school bus purchased for use in Louisiana by or for a public school or school district shall meet Federal Motor Vehicle Safety Standards in effect at the time the bus was manufactured and shall meet Louisiana legal requirements for school buses at the time the bus is placed into service.
- D. All replacement school buses used by owner-operators, school districts or private contractors on daily routes, at the time they are acquired by the owner, must be ten (10) or fewer years old. The number of years shall be reckoned from the date of the introduction of the model year. (See “Calculating the Age of School Buses By Model Year,” this Section).
- E. Any school bus used as an activity or backup (aka “spare”) bus, at the time it is acquired by the owner and placed in service, shall be fifteen (15) or fewer model years old. The number of years shall be reckoned from the date of the introduction of the model year. (See “Calculating the Age of School Buses by Model Year,” this Section).
- F. In addition to FVMSSs, Louisiana statutory specifications and applicable LDE regulations, school buses purchased for the purpose of transporting Head Start students must comply with requirements stated in 45 CFR 1310.
- G. The responsibility of compliance with school bus specifications rests with the vendors, manufacturers and purchasers of school buses.
- H. The vendor who sells a school bus shall, upon delivery, certify to the purchaser (LEA, individual or contractor), that the school bus(es) sold for use by a Louisiana public school or school district meets or exceeds FMVSSs at the time of manufacture, Louisiana statutory requirements and all purchaser’s supplementary specifications in effect at the time the bus is purchased. (See LDE Form T-10 and Sample compliance for Head Start school buses—Appendix D.)
- I. The seller of any new or used school bus shall complete a school bus purchase document (Form T-10—see Appendix D) verifying that the purchased vehicle meets all state and federal school bus specifications applicable at the time of manufacture, Louisiana equipment requirements and all purchaser’s supplementary specification in effect at the time the bus is purchased.
- J. The seller shall provide an original Form T-10 for each bus sold to the purchaser, who shall maintain a copy of the form throughout the purchaser’s ownership of every bus.
- K. T-10 forms shall be forwarded to the Louisiana Department of Education upon request.
- L. At the time of purchase, the seller of any school bus must disclose to the purchaser, which components of the vehicle are subject to a manufacturer’s or vendor’s warranty agreement.
- M. Notwithstanding any provision of this Section (of R.S. 17:493.1) to the contrary, whenever a school

bus operator owning his own bus retires, a route shall be offered first to any person meeting the requirements of the school board who is willing to acquire the bus of the retiring operator by a method which guarantees that the operator receives full appraised value for his bus using regularly accepted appraisal methods to determine fair market value. The provisions of this Subsection shall be applicable only when the bus owned by the retiring operator has been manufactured within a period of five years immediately prior to the operator's retirement and the operator is retiring due to a documented physical disability.

- N. City and parish school boards are authorized to purchase school buses and to resell the buses to school bus operators who are employed by the board or with whom the board has contracted to provide transportation services for students. Details of such transactions and related requirements are available at R.S. 17:158.2.

SALES TAX EXCLUSION FOR SCHOOL BUS PURCHASES BY INDEPENDENT OPERATORS

- A. Independent operators may be exempt from paying sales taxes under the following conditions (R.S. 47:301(10)(i):
1. The school bus must be used exclusively for the purpose of transporting children to and from public schools; and
 2. The bus must be new or less than five (5) years old.
- B. The exclusion shall apply to all sales and use taxes, including those taxes levied by any local political sub-division.

FROZEN MILEAGE FOR OWNER/OPERATORS

- A. Frozen ("guaranteed") mileage applies to owner/operators who are employees of a school district and who purchase a new or pre-owned school bus as a condition of initial employment or to replace an existing school bus, with the following additional provisions:
1. The LEA authorizes the owner/operator to purchase a school bus and specifies the age requirement and the manufacturer's rated capacity of a bus to be purchased (See sample procedure—Appendix D);
 2. The LEA audits the owner/operator's route mileage to establish the official mileage to be frozen before a purchase is authorized (See sample authorization form—Appendix D); and
 3. The owner/operator provides the LEA with a T-10 Form with complete information provided by the vendor and the purchaser (See Form T-10--Appendix D)
- B. Mileage will be "frozen"—that is, operational compensation may not be reduced—for a period of seven (7) school years from the date the purchased bus was placed in service if the bus was not pre-owned, although operational compensation will be increased if route mileage is increased above the pre-purchase audited mileage.
- C. Mileage will be "frozen"—that is, operational compensation may not be reduced—for a period of five (5) school years from the date the purchased bus was placed in service if the bus was pre-owned but was manufactured within five (5) years of the purchase date, although operational compensation will be increased if route mileage is increased above the pre-purchase audited mileage.
- D. Frozen mileage cannot be passed from one owner/operator to another owner/operator.
- E. The transfer of a bus from spouse to spouse, acquisition as a gift, etc., other than a purchase does not afford frozen mileage to the person who acquires the bus.
- F. If an owner/operator's actual route mileage falls below the level of frozen mileage, the owner/operator shall accept longer route assignments or forfeit the benefit of frozen mileage.

SCHOOL BUS INSURANCE

- A. LEAs have the authority to enter into and consummate contracts for insurance covering loss of life or personal injury of the children while being transported to and from school and school related activities (RS 17:159).
- B. All premiums for all insurance policies of public liability and property damage insurance applying to and covering **school buses owned by LEAs** shall be the obligation of and payable by, the board owning such buses [RS 17:159.2(A)] .
- C. LEAs are not prevented from paying the premiums for public liability and property damage insurance covering and applying to privately owned buses used for transportation of students on behalf of the LEA [RS 17:159.2(B)].
- D. State law authorizes LEAs contracting for the use of privately-owned school buses to procure contracts on a fleet or group basis for the owners who are insuring the vehicles [RS 17:159.1(A)].
- E. The amounts required, or to be required, during each year to make the premium payments may be withheld from compensation due the owners in equal monthly installments [RS 17:159.1(B)].

SCHOOL BUS LEASES

- A. LEAs may lease a school bus owned by any school bus operator employed by the LEA or with whom the LEA has contracted to provide transportation services for students from the school bus operator or by a business who is authorized by the state of Louisiana to sell, lease or operate school buses in the state (R.S. 17:158.7).
- B. The school bus shall be used by the operator to transport students on the operator's assigned bus route, or the school bus may be used by the school district to transport students on assigned bus routes and/or for activity trips.
- C. Lease agreements must follow state regulations as described in R.S. 17:158 and R.S. 17:158.7.
- D. Lease agreements must specify that every bus included in the lease has been inspected and certified to meet all applicable federal and state standards and statutory requirements as enumerated or otherwise referenced in this document.

MEASURING SCHOOL BUS BODIES TO DETERMINE OPERATORS' COMPENSATION

- A. Base state-mandated salary computations for school bus operators (R.S. 17:496) and operational pay for owner/operators (R.S. 17:497) are determined by the lengths of buses they operate.
- B. For purposes of determining compensation, the bus body is measured from the base of the windshield to the exterior of the rear of the school bus body, excluding the rear bumper.

SCHOOL BUS REPAIRS AND MAINTENANCE

- A. Repairs or alterations to school buses that transport children to school or related activities shall be made in compliance with FMVSSs in effect at the time the respective buses were manufactured and state specifications in effect at the time of the repairs or alterations.
- B. School bus warranty repair work shall be performed by repair facilities authorized by the manufacturer or distributor.
- C. Manufacturers of school buses licensed by the Louisiana Motor Vehicle Commission are authorized to provide warranty and other repair or maintenance services to be performed at any location of a licensed motor vehicle dealer which holds a franchise from any affiliate or subsidiary of the school bus manufacturer.

SCHOOL BUSES SOLD FOR NON-SCHOOL TRANSPORTATION PURPOSES

Every school bus sold or transferred to any use other than school activities in Louisiana shall be painted by the new owner a color other than national school bus yellow and all lettering of school bus identification and all semaphore arms and alternately flashing signal lights shall be removed from the bus (R.S. 17:162).

CALCULATING THE AGES OF SCHOOL BUSES

- A. The age of a school bus is calculated from the date of introduction of the model year (R.S. 17:158.2) of the bus.
- B. From the date the model was introduced to the first anniversary of the model’s introduction is zero, the following year is one, etc. (See “Calculating the Ages of School Buses by Model Year” chart on the following page.)

CALCULATING THE AGES OF SCHOOL BUSES BY MODEL YEAR

[*Model Years may begin in September or later in previous calendar years or in January of current calendar years. Date of manufacture is indicated inside each school bus on a body data plate. **School buses shall be retired from service when they reach twenty-five years from the date of introduction of the model year (R.S. 17:158.2.)**]

O SCHOOL BUS MODEL YEAR	CALENDAR-YEAR ANNIVERSARY					
	2019	2020	2021	2022	2023	ETC.
2023					25	
2022				25	24	
2021			25	24	23	
2020		25	24	23	22	
2019	25	24	23	22	21	
2018	24	23	22	21	20	
2017	23	22	21	20	19	
2016	22	21	20	19	18	
2015	21	20	19	18	17	
2014	20	19	18	17	16	
2013	19	18	17	16	15	
2012	18	17	16	15	14	
2011	17	16	15	14	13	
2010	16	15	14	13	12	
2009	15	14	13	12	11	
2008	14	13	12	11	10	
2007	13	12	11	10	9	
2006	12	11	10	9	8	
2005	11	10	9	8	7	
2004	10	9	8	7	6	
2003	9	8	7	6	5	
2002	8	7	6	5	4	
2001	7	6	5	4	3	
2000	6	5	4	3	2	
1999	5	4	3	2	1	
1998	4	3	2	1	○	
1997	3	2	1	○		
1996	2	1	○			
1995	1	○				
1996	○					

SCHOOL BUS BODY AND CHASSIS SPECIFICATIONS

INTRODUCTION TO SCHOOL BUS SPECIFICATIONS

The specifications published in this section of Supplement I apply to school buses that are purchased, leased, rented or otherwise used for the purpose of transporting students to or from school or related activities. The specifications incorporate most of the specifications recommended by the National Congress on School Transportation, in 2015. A careful review of the specifications by manufacturers, vendors and other interested parties, however, will reveal that revisions have been made to accommodate specific Louisiana requirements. **Responsibility for assuring compliance with all Louisiana specifications rests with school bus or related product vendors and with purchasers.** As these specifications are revised and adopted by the Louisiana Department of Education, chassis, body and related equipment manufacturers shall incorporate revised specifications in their products as appropriate or necessary.

Every attempt has been made to eliminate conflicts between these specifications and federal regulations. Should conflicts be found to exist or arise through new federal regulations, by legally binding interpretations of those regulations or by Louisiana statutory mandates, they should be brought to the attention of the Louisiana Department of Education. Revisions to this document will be made to accommodate essential revisions.

The vehicle specifications contained herein are intended to apply primarily to **new vehicles**, including all types of school buses, as defined in Appendix A: Terms and Definitions. **Multi-function school activity buses (MFSABs)**, however, are not authorized in Louisiana for transporting students to and from school and school-related activities due to statutes addressing school bus paint color, stop signals and overhead eight-way flashing lamps. References to MFSABs have been retained in anticipation of approval by the Louisiana Legislature in future sessions.

Vendors, prospective buyers, maintenance and repair technicians and supervisory personnel are encouraged to review the preceding section entitled “Miscellaneous School Bus Regulations,” which includes important information regarding sales, purchase and maintenance requirements and responsibilities.

Specifications applicable to **Head Start vehicles**, as may be enumerated in 45 CFR 1310, shall prevail, except for Louisiana statutory requirements where applicable (e.g., two stop signals, crossing control arm, backing alarm, drug-free and firearm-free signage, etc.).

Specifications for **pre-owned school buses** shall comply with specifications applicable to the date of manufacture and to applicable Louisiana statutes that are in effect at the time the bus is placed into service in Louisiana.

RESPONSIBILITY FOR COMPLIANCE

- A. The responsibility for compliance with school bus and related equipment specifications rests with the manufacturers, vendors, purchasers, inspectors and maintenance and repair technicians.
- B. If any vendor or manufacturer sells school transportation equipment that does not conform to all applicable state and federal specifications, the vendor shall be required to make necessary conversions to bring the vehicle into compliance. **All costs related to such alteration shall be borne by the vendor.**
- C. School bus manufacturers shall certify compliance with applicable federal standards by installing a certification plate or label in the driver’s area on each vehicle.
- D. Vendors must certify compliance with applicable FMVSSs and with Louisiana requirements at the time a school bus or related equipment is sold.
- E. Louisiana Department of Education Form T-10 (see Appendix A and Appendix D) shall be

completed by the vendor and purchaser, as indicated, for new and pre-owned school buses. Copies of T-10 forms shall be maintained by vehicle owners and by respective LEAs (as applicable) for the useful life of the bus in the service of the LEA or private owner.

- F. As the school bus or related equipment is maintained over its useful life, it is the responsibility of those who supervise and perform work on the vehicle or related equipment to assure on-going compliance with all applicable federal and state standards and specifications, as well to coordinate recalls. For this reason, maintenance personnel training, quality components, quality workmanship and thorough maintenance records are essential.
- G. Any school bus that does not meet the applicable specifications enumerated in this edition must be removed from service until such time the bus is in full compliance.

SCHOOL BUS TYPES



TYPE A: A Type A school bus is a conversion bus constructed utilizing a cutaway front section vehicle with a left side driver's door. This definition includes two classifications: Type A-1, with a gross vehicle weight rating (GVWR) of 14,500 pounds or less; and a Type A-2, with a GVWR greater than 14,500 pounds and less than or equal to 21,500 pounds.



TYPE B: A Type B school bus is constructed utilizing a stripped chassis. The entrance door is behind the front wheels. This definition includes two classifications: Type B-1, with a GVWR of 10,000 pounds or less, and Type B-2, with a GVWR greater than 10,000 pounds.



TYPE C: A Type C school bus is constructed utilizing a chassis with a hood and front fender assembly. The entrance door is behind the front wheels—also known as a conventional-style school bus. This type also includes the cutaway truck chassis or truck chassis with cab with or without a left side door and with a GVWR greater than 21,500 pounds.



Type D: A Type D school bus is constructed utilizing a stripped chassis. The entrance door is ahead of the front wheels—also known as a rear-engine or front-engine transit-style bus.

BUS BODY AND CHASSIS SPECIFICATIONS

GENERAL REQUIREMENTS

- A. No vehicle with a rated capacity of ten (10) or more passengers (excluding the driver) shall be classified as a *school bus* and thereby used to transport students to and fro school and school-related activities, unless said vehicle originally was manufactured and certified as a *school bus* and maintained the certification throughout the life of the vehicle.
- B. All school buses and school bus equipment (owned, leased, rented or under contract) shall meet or exceed all applicable FMVSSs at the time of manufacture.
- C. All school buses shall comply with Louisiana statutory and Department of education regulatory requirements throughout the time they are used to transport students to and from school or school related activities.
- D. All replacement school buses used on daily routes and/or activity trips by all owner/operators, schools, school districts and private transportation companies, at the time they are acquired by the owner, must be ten (10) or less model years old, unless conforming with specific qualifications stated in Sub-sections F and G, below. The number of years shall be reckoned from the date of the introduction of the model year model year. (See “Calculating the Ages of School Buses by Year of Manufacture” in the previous section of this document.)
- E. Any school bus used as an activity or backup bus, at the time it is acquired by the owner and placed in service, shall be fifteen or fewer model years old. The number of years shall be reckoned from the date of introduction of the model year. (R.S. 17:158.2.D)
- F. Any school bus used as an activity or backup bus that is older than fifteen model years shall not be used more than sixty consecutive school days in a school year. (R.S. 17:158.2.E.)
- G. No school bus used to transport students, including an activity or backup (spare) bus, shall exceed the age of twenty-five (25) model years, reckoned from the date of manufacture stamped on the data plate provided by the manufacturer at the time of manufacture (R.S. 17:158.2.D.). (See “Calculating the Ages of School Buses by Year of Manufacture” at the end of the Miscellaneous Transportation Equipment Regulations section.)
- H. School buses assigned to transport Head Start students shall meet the above applicable requirements and all applicable Head Start vehicle and safety restraint requirements as set forth in 45 CFR 1310 and related regulations.

AIR CLEANER

- A. A dry element air cleaner shall be provided.
- B. All diesel engine air filters shall include a latch-type restriction indicator that retains the maximum restriction developed during operation of the engine. The indicator should include a reset control so the indicator can be returned to zero when desired.

AISLE

All emergency exit doors shall be accessible by a 12-inch minimum aisle. The aisle shall be unobstructed at all times by any type of barrier, seat, wheelchair or tie-down, unless a flip seat is installed and occupied. The track of a track seating system is exempt from this requirement. A flip seat in the unoccupied (up) position shall not obstruct the 12-inch minimum aisle to any side emergency exit door.

AXLES

The front and rear axle and suspension systems shall have a gross axle weight rating (GAWR) at ground commensurate with the respective front and rear weight loads of the bus loaded to the rated passenger capacity.

BACK-UP WARNING ALARM

Every new school bus ordered or purchased after August 15, 1993, and every used bus not in service as a school bus on that date, but put into service as a school bus thereafter, shall be equipped with an automatic back-up audible alarm which sounds on backing and which is capable of emitting sound audible under normal conditions from a distance of not less than one hundred feet. The alarm shall also be capable of operating automatically when the vehicle is in neutral or a forward gear but rolls backward. (R.S. 32:378.D)

BRAKES: GENERAL

- A. The chassis brake system shall conform to the provisions of FMVSS Nos. 105, Hydraulic and Electric Brake Systems, 106, Brake Hoses, and 121, Air Brake Systems, as applicable. All buses shall have either a parking pawl in the transmission or a park brake interlock that requires the service brake to be applied to allow release of the parking brake.
- B. The anti-lock brake system (ABS), provided in accordance with FMVSS No. 105, Hydraulic and Electric Brake Systems or No. 121, Air Brake Systems, shall provide wheel speed sensors for each front wheel and for each wheel on at least one rear axle. The system shall provide anti-lock braking performance for each wheel equipped with sensors (Four-Channel System).
- C. All brake systems shall be designed to permit visual inspection of brake lining wear without removal of any chassis component(s).
- D. The brake lines, booster-assist lines, and control cables shall be protected from excessive heat, vibration and corrosion and installed in a manner that prevents chafing.
- E. The parking brake system for either air or hydraulic service brake systems may be of a power-assisted design. The power parking brake actuator should be a device located on the instrument panel within reach of a seated 5th percentile female driver. As an option, the parking brake may be set by placing the automatic transmission shift control mechanism in the "park" position.
- F. The power-operated parking brake system may be interlocked to the engine key switch. Once the parking brake has been set and the ignition switch turned to the "off" position, the parking brake cannot be released until the key switch is turned back to the "on" position.

BRAKES: HYDRAULIC

Buses using hydraulic-assist brakes shall meet requirements of FMVSS 105.

BRAKES: AIR

- A. The air pressure supply system shall include a desiccant-type air dryer installed according to the manufacturer's recommendations. The air pressure storage tank system may incorporate an automatic drain valve.
- B. The chassis manufacturer shall provide an accessory outlet for air-operated systems installed by the body manufacturer. This outlet shall include a pressure protection valve to prevent loss of air pressure in the service brake reservoir.
- C. For air brake systems, an air pressure gauge shall be provided in the instrument panel capable of complying with Commercial Driver's License (CDL) pre-trip inspection requirements.
- D. Air brake systems shall include a system for anti-compounding of the service brakes and parking brakes.
- E. Air brakes shall have both a visible and audible warning device whenever the air pressure falls below the level where warnings are required under FMVSS No. 121, Air Brake Systems.

BUMPER: FRONT

- A. School buses shall be equipped with a front bumper.
- B. The front bumper on buses of Type A-2 (with GVWR greater than 14,500 pounds), Type B, Type C, and Type D shall be equivalent in strength and durability to pressed steel channel at least 3/16 inches thick and not less than 8 inches wide (high). It shall extend beyond the forward-most part of the body, grille, hood and fenders and shall extend to the outer edges of the fenders at the bumper's top line. Type A buses having a GVWR of 14,500 pounds or less may be equipped with an OEM-supplied front bumper. The front bumper shall be of sufficient strength to permit being pushed by another vehicle on a smooth surface with a 5-degree, (8.7 percent) grade, without permanent distortion. The contact point on the front bumper is intended to be between the frame rails, with as wide a contact area as possible. If the front bumper is used for lifting, the contact points shall be under the bumper attachments to the frame rail brackets unless the manufacturer specifies different lifting points in the owner's manual. Contact and lifting pressures should be applied simultaneously at both lifting points.
- C. The front bumper, except breakaway bumper ends, shall be of sufficient strength to permit pushing a vehicle of equal gross vehicle weight, per Section B, without permanent distortion to the bumper, chassis or body.
- D. The bumper shall be designed or reinforced so that it will not deform when the bus is lifted by a chain that is passed under the bumper (or through the bumper if holes are provided for this purpose) and attached to both tow hooks/eyes. For the purpose of meeting this specification, the bus shall be empty and positioned on a level, hard surface, and both tow hooks/eyes shall share the load equally.

BUMPER: REAR

- A. The bumper on Type A-1 buses shall be a minimum of 8 inches wide (high). Bumpers on Types A-2, B, C and D buses shall be a minimum of 9½ inches wide (high). The bumper shall be of sufficient strength to permit being pushed by another vehicle of similar size and being lifted by the bumper without permanent distortion.
- B. The bumper shall wrap around the back corners of the bus. It shall extend forward at least 12 inches, measured from the rear-most point of the body at the floor line, and shall be mounted flush with the sides of the body or protected with an end panel.
- C. The bumper shall be attached to the chassis frame in such a manner that it may be removed. It shall be braced to resist deformation of the bumper resulting from impact from the rear or the side. It shall be designed to discourage hitching of rides by an individual.
- D. The bumper shall extend at least one inch beyond the rear-most part of the body surface, measured at the floor line.
- E. The bottom of the rear bumper shall not be more than 30 inches above ground level.

CERTIFICATION

- A. The chassis and body manufacturer(s) shall certify that its(their) product(s) meets Louisiana's minimum standards on items which are not covered by FMVSS certification requirements of 49 CFR, Part 567: Certification. Louisiana Department of Education Form T-10 (see Appendix D) shall be provided by the vendor to the purchaser for each school bus sold for the purpose of transporting school students in Louisiana.

COLOR

- A. The school bus body shall be painted National School Bus Yellow (NSBY). (See paint formula, Appendix B.)
- B. The body exterior trim, as defined by Louisiana, shall be black.
- C. Except for the vertical portion of the front and rear roof caps, the roof of the bus may be painted white. (See illustration in Appendix B, Placement of Retroreflective Markings.)
- D. The chassis and front bumper shall be painted glossy black, except that for increased night visibility they may be covered with a retroreflective material (R.S. 32:378.A.).
- E. The body, cowl, hood and fenders shall be in National School Bus Yellow (NSBY). (See Appendix B.)
- F. Wheels shall be black (no chrome permitted).
- G. Any school bus **acquired for any purpose other than transporting children to and from school** shall be painted a color other than national school bus glossy yellow and all lights, signals, and other devices and any lettering identifying the vehicle as a school bus shall be removed (R.S. 32:378.B).

COMMUNICATIONS SYSTEMS

- A. Each bus shall have a two-way communication system capable of providing communication with the operation's base, or at least local 911 operators where technologically feasible. All school buses that transport individuals with disabilities should be equipped with a two-way electronic voice communication system that can be used at any point on the vehicle's route.
- B. The end user shall be responsible for the purchase, installation and maintenance of the two-way communication system.

CONSTRUCTION

- A. Side Intrusion Test: The bus body shall be constructed to withstand an intrusion force equal to the curb weight of the vehicle or 20,000 pounds, whichever is less. Each vehicle shall be capable of meeting this requirement when tested in accordance with the procedures set forth below. The complete body structure, or a representative seven-body section mock up with seats installed, shall be load-tested at a location 24 ± 2 inches above the floor line, with a maximum 10 inch-diameter cylinder, 48 inches long, mounted in a horizontal plane.

The cylinder shall be placed as close as practical to the mid-point of the tested structure, spanning two internal vertical structural members. The cylinder shall be statically loaded to the required force of curb weight or 20,000 pounds, whichever is less, in a horizontal plane with the load applied from the exterior toward the interior of the test structure. When the minimum load has been applied, the penetration of the loading cylinder into the passenger compartment shall not exceed 10 inches from its original point of contact. There can be no separation of lapped panels or construction joints. Punctures, tears or breaks in the external panels are acceptable but are not permitted on any adjacent interior panel. Body companies shall certify compliance with this intrusion requirement, and include test results, as requested.
- B. Construction shall be reasonably dust-proof and watertight.

CROSSING CONTROL ARM (CROSSING GATE)

- A. School buses shall be equipped with a crossing control arm (R.S. 17: 164.1) mounted on the right side of the front bumper. When opened, this arm shall extend in a line parallel to the body side and aligned with the right front wheel.
- B. All components of the crossing control arm and all connections shall be weatherproofed.
- C. The crossing control arm shall incorporate system connectors (electrical, vacuum or air) at the gate and shall be easily removable to allow for towing of the bus.
- D. The crossing control arm shall be constructed of non-corrodible or nonferrous material or shall be treated in accordance with the body sheet metal specification. (See BUS BODY AND CHASSIS SPECIFICATIONS, Metal Treatment.)
- E. There shall be no sharp edges or projections that could cause injury or be a hazard to students. The end of the arm shall be rounded.
- F. The crossing control arm shall extend a minimum of 70 inches (measured from the bumper at the arm assembly attachment point) when in the extended position. The crossing control arm shall not extend past the end of the bumper when in the stowed position.
- G. The crossing control arm shall extend simultaneously with the stop signal arm(s), activated by stop signal arm controls.
- H. An automatic recycling interrupt switch may be installed for temporarily disabling the crossing control arm.
- I. The assembly shall include a device attached to the bumper near the end of the arm to automatically retain the arm while in the stowed position. That device shall not interfere with normal operations of the crossing control arm.

DEFROSTERS

- A. Defrosting and defogging equipment shall direct a sufficient flow of heated air onto the windshield, the window to the left of the driver and the glass in the viewing area directly to the right of the driver to eliminate frost, fog and snow.
Note: The requirements of this standard do not apply to the exterior surfaces of double pane storm windows.
- B. The defrosting system shall conform to SAE J381, Windshield Defrosting Systems Test Procedure and Performance Requirements—Trucks, Buses, and Multipurpose Vehicles.
- C. The defroster and defogging system shall be capable of furnishing heated, outside ambient air, except that the part of the system furnishing additional air to the windshield, entrance door and stepwell may be the re-circulating air type.
- D. Auxiliary fans are not considered defrosting or defogging systems.
- E. Portable heaters shall not be used.

DOORS

- A. The entrance door shall be under the driver's control, designed to afford easy release and to provide a positive latching device on manual operating doors to prevent accidental opening. When a hand lever is used, no part shall come together that will shear or crush fingers. Manual door controls shall not require more than 25 pounds of force to operate at any point throughout the range of operation, as tested on a 10% grade, both uphill and downhill.
- B. The entrance door shall be located on the right side of the bus, opposite and within direct view of the driver.
- C. The entrance door shall have a minimum horizontal opening of 24 inches and a minimum vertical opening of 68 inches.

- D. The entrance door shall be a split-type door and shall open outward.
- E. All entrance door glass shall be approved safety glass. The bottom of each lower glass panel shall be not more than 10 inches from the top surface of the bottom step. The top of each upper glass panel when viewed from the interior shall be not more than 3 inches below the interior door control cover or header pad.
- F. Vertical closing edges on entrance doors shall be equipped with flexible material.
- G. All door openings shall be equipped with padding at the top edge of the opening. Padding shall be at least three inches wide and one inch thick and extend the full width of the door opening.
- H. On power-operated entrance doors, the emergency release valve, switch or device to release the entrance door must be placed above or to the immediate left or immediate right of the entrance door and must be clearly labeled. The emergency release valve, switch or device shall work in the absence of power.

DRIVE SHAFT

The drive shaft shall be protected by a metal guard or guards around the circumference of the drive shaft to reduce the possibility of the drive shaft's whipping through the floor or dropping to the ground, if broken.

ELECTRICAL SYSTEM

A. Battery

1. The storage batteries shall have minimum cold cranking capacity rating (cold cranking amps) equal to the cranking current required for 30 seconds at 0 degrees Fahrenheit and a minimum reserve capacity rating of 120 minutes at 25 amps. Higher capacities may be required, depending upon optional equipment and local environmental conditions.
2. The manufacturer shall securely attach the battery on a slide-out or swing-out tray in a closed, vented compartment in the body skirt or chassis frame so that the battery is accessible for convenient servicing from the outside. When in the stored position, the tray shall be retained by a securing mechanism capable of holding the tray [with battery(ies)] in position when subjected to a 5g load from any direction. The battery compartment door or cover, if separate from the tray, shall be hinged at the front or top. It shall be secured by a positive operated latching system or other type fastener. The door may be an integral part of the battery slide tray. The door or cover must fit tightly to the body, and not present sharp edges or snagging points. Battery cables shall meet SAE requirements. Battery cables shall be of sufficient length to allow the battery tray to fully extend. Any chassis frame-mounted batteries shall be relocated to a battery compartment on Type A buses
3. All batteries are to be secured in a sliding tray except that on van conversion or cutaway front-section chassis, batteries may be secured in accordance with the manufacturer's standard configuration. In these cases, the final location of the battery and the appropriate cable lengths shall be agreed upon mutually by the chassis and body manufacturers. However, in all cases the battery cable provided with the chassis shall have sufficient length to allow some slack, and shall be of sufficient gauge to carry the required amperage.
4. Buses may be equipped with a battery shut-off switch. The switch is to be placed in a location not readily accessible to the driver or passengers.

B. Alternator

1. All Type A and Type B buses with a GVWR of 15,000 pounds or less shall have a minimum 130-amp alternator. Buses equipped with an electrically powered wheelchair lift and/or air conditioning shall be equipped with the highest rated capacity available from the chassis OEM.
2. All buses over 15,000 pounds GVWR shall be equipped with a heavy-duty truck-or bus-type

alternator having a minimum output rating of 200 amps or higher, and should produce a minimum current output of 50 percent of the rating at engine idle speed.

3. All other buses than those described in B1 equipped with an electrically powered wheelchair lift and/or air conditioning shall have a minimum alternator output of 240 amps and may be equipped with a device that advances the engine idle speed when the voltage drops to, or below, a pre-set level.
4. A belt-driven alternator shall be capable of handling the rated capacity of the alternator with no detrimental effect on any other driven components. (For estimating required alternator capacity, see School Bus Manufacturers Technical Council's publication, "School Bus Technical Reference," available at <http://www.nasdpts.org>.)
5. A direct/gear-drive alternator is permissible in lieu of a belt-driven alternator.

C. Electrical Components

Materials in all electrical components shall contain no mercury.

D. Wiring, Chassis

1. All wiring shall conform to current applicable recommended practices of the Society of Automotive Engineers (SAE). All wiring shall use color and at least one other method for identification. The other method shall be either a number code or name code, and each chassis shall be delivered with a wiring diagram that illustrates the wiring of the chassis.
2. The chassis manufacturer of an incomplete vehicle shall install a readily accessible terminal strip or connector on the body side of the cowl or in an accessible location in the engine compartment of vehicles designed without a cowl. The strip or connector shall contain the following terminals for the body connections:
 - a. Main 100-amp body circuit;
 - b. Tail lamps;
 - c. Right turn signal;
 - d. Left turn signal;
 - e. Stop lamps;
 - f. Back-up lamps; and
 - g. Instrument panel lamps (controlled by dimmer switch).
3. An appropriate identifying diagram (color plus a name or number code) for all chassis electrical circuits shall be provided to the body manufacturer for distribution to the end user.
4. Wiring for the headlamp system must be separate from the electronic controlled body solenoid/module.

E. Wiring, Body

1. All wiring shall conform to current applicable SAE recommended practices.
2. All wiring shall have an amperage capacity exceeding the design load by at least 25%. All wiring splices are to be accessible and noted as splices on the wiring diagram.
3. A body wiring diagram, sized to be easily read, shall be furnished with each bus body or affixed to an area convenient to the electrical accessory control panel.
4. The body power wire shall be attached to a special terminal on the chassis.
5. Each wire passing through metal openings shall be protected by a grommet.
6. Wires not enclosed within the body shall be fastened securely at intervals of not more than 18 inches. All joints shall be soldered or joined by equally effective connectors, which shall be water-resistant and corrosion-resistant.
7. Wiring shall be arranged in circuits, as required, with each circuit protected by a fuse breaker

or electronic protection device. A system of color and number-coding shall be used and an appropriate identifying diagram shall be provided to the end user, along with the wiring diagram provided by the chassis manufacturer. The wiring diagrams shall be specific to the bus model supplied and shall include any changes to wiring made by the body manufacturer. Chassis wiring diagrams shall be supplied to the end user. The following body interconnecting circuits shall be color-coded, as noted:

FUNCTION	COLOR
Left Rear Directional Lamp	Yellow
Right Rear Directional Lamp	Dark Green
Stop Lamps	Red
Back-up Lamps	Blue
Tail Lamps	Brown
Ground	White
Ignition Feed, Primary Feed	Black

The color of the cables shall correspond to SAE J1128, *Low-Tension Primary Cable*.

8. Wiring shall be arranged in at least six regular circuits, as follows:
 - a. Head, tail, stop (brake), clearance and instrument panel lamps;
 - b. Step well lamps shall be actuated when the entrance door is open;
 - c. Dome lamps;
 - d. Ignition and emergency door signal;
 - e. Turn signal lamps; and
 - f. Alternately flashing signal lamps.
 9. Any of the above combination circuits may be subdivided into additional independent circuits.
 10. Heaters and defrosters shall be wired on an independent circuit.
 11. Whenever possible, all other electrical functions (such as sanders, if equipped, and electric-type windshield wipers) shall be provided with independent and properly protected circuits.
 12. Each body circuit shall be coded by number or letter on a diagram of circuits and shall be attached to the body in a readily accessible location.
- F. Buses may be equipped with a 12-volt power port in the driver's area.
 - G. There shall be a manual noise suppression switch installed in the control panel. The switch shall be labeled and alternately colored. This switch shall be an on/off type, which deactivates body equipment that produces noise, including at least the AM/FM radio, heaters, air conditioners, fans and defrosters. This switch shall not deactivate safety systems, such as windshield wipers, lighting systems or child check systems. Once the switch has been reactivated, all electronic controls shall return to their original operations without driver reset.
 - H. The entire electrical system of the body shall be designed for the same voltage as the chassis on which the body is mounted.

ELECTRONIC STABILITY CONTROL (ESC)

Buses should be equipped with Electronic Stability Control (ESC).

EMERGENCY EQUIPMENT

Head Start buses shall have locations of emergency equipment indicated by appropriate signage (45 CFR 1310.10(d)(2, 3 and 4).

A. Fire Extinguisher

1. The bus shall be equipped with at least one UL-approved pressurized, dry chemical fire extinguisher. The extinguisher shall be secured in a mounted bracket, located in the driver's compartment and readily accessible to the driver and passengers. A pressure gauge shall be mounted on the extinguisher and shall be easily read without moving the extinguisher from its mounted position.
2. The fire extinguisher shall have a rating of 2-A:10-BC, or greater. The operating mechanism shall be secured with a type of seal that will not interfere with the use of the fire extinguisher.

B. First Aid Kit

1. The bus shall have a removable, moisture-proof and dust-proof first aid kit in an accessible place in the driver's compartment. It shall be mounted and identified as a first aid kit. The location for the first aid kit shall be marked.
2. Contents shall include:
 - 2 – 1-inch x 2 ½ yards of adhesive tape rolls
 - 24 – Sterile gauze pads 3x3 inches
 - 100 – ¾ x 3 inches adhesive bandages
 - 8 – 2-inch bandage compress
 - 10 – 3-inch bandage compress
 - 2 – 2-inch x 6 foot sterile gauze roller bandages
 - 2 – Non-sterile triangular bandages, minimum 39x35x54 inches with two safety pins
 - 3 – Sterile gauze pads 36x36 inches
 - 3 – Sterile eye pads
 - 1 – Rounded-end scissors
 - 1 – Pair nitrile medical examination gloves
 - 1 – Mouth-to-mouth airway

C. Body Fluid Clean-Up Kit

Each bus shall have a removable, moisture-proof body fluid clean-up kit stored in a metal container, accessible to the driver. The kit shall be properly mounted and identified as a body fluid clean-up kit and must meet OSHA regulations.

D. Warning Devices

Each school bus shall contain three retroreflective triangle road warning devices that meet the requirements of FMVSS No. 125, Warning Devices. They shall be mounted in an accessible place.

- E. Any piece of emergency equipment may be mounted in an enclosed compartment, provided the compartment is labeled in not less than one-inch letters, identifying each piece of equipment contained therein.

EMERGENCY EXITS

- A. Any installed emergency exit shall comply with the design and performance requirements of FMVSS No. 217, *Bus Emergency Exits and Window Retention and Release*, applicable to that type of exit, regardless of whether or not that exit is required by FMVSS No. 217.
- B. Emergency Window Requirements
1. On vehicles equipped with rear engines, the rear emergency window shall have a lifting assistance device that will aid in lifting and holding the rear emergency window open.
 2. Side emergency exit windows shall be vertically hinged on the forward side of the window or horizontally hinged on the bottom of the window.
 3. No side emergency exit window will be located above a stop arm.
- C. Emergency Door Requirements
1. The exposed area of the upper panel of emergency doors shall be a minimum of 400 square inches of approved safety glazing.
 2. If installed, all other glass panels on emergency doors shall be approved safety glazing.
 3. There shall be no steps leading to an emergency door.
 4. There shall be no obstruction higher than ¼ inch across the bottom of any emergency door opening. Fasteners used within the emergency exit opening shall be free of sharp edges or burrs.
- D. Emergency Exit Requirements

The use of the following tables is to determine the required number and types of emergency exits to comply with this specification, based on the bus manufacturer's equipped seating capacity.

1. Use Table 1 if the bus contains a rear emergency door, or
2. Use Table 2 if the bus contains a rear pushout emergency window AND a left side emergency door, as required by FMVSS No. 217 for school buses without a rear emergency door.
3. When using either Table 1 or Table 2:
 - a. Enter the Table at the appropriate "CAPACITY" and select the desired row from the options for that capacity.
 - b. A school bus will meet the requirements of this specification and the requirements of FMVSS 217 if it contains the types and quantities of emergency exits listed on the row selected.

TABLE 1 BUSES WITH REAR EMERGENCY DOOR (All Front Engine Buses)						TABLE 2 BUSES WITH REAR PUSHOUT WINDOW AND LEFT SIDE EMERGENCY DOOR (All Rear Engine Buses)					
Available Combinations By Capacity	Manufacturers Equipped Capacity	Shall Have	And Shall Also Have			Available Combinations By Capacity	Manufacturers Equipped Capacity	Shall Have	And Shall Also Have		
		Roof Hatch	L. Side Emerg. Exit Windows	R. Side Emerg. Exit Windows	L. Side Emerg. Exit Door			Roof Hatch	L. Side Emerg. Exit Windows	R. Side Emerg. Exit Windows	R. Side Emerg. Exit Door
1-45	1-45	1	0	0	0	1-45	1-45	1	0	0	0
46-77	46-77	2	1	1	0	46-89	46-89	2	1	1	0
	46-77	2	0	0	1		46-89	2	0	0	1
78-93	78-93	2	2	2	0	90-105	90-105	2	2	2	0
	78-93	2	1	1	1		90-105	2	1	1	1

EXHAUST SYSTEM

- A. The exhaust pipe, after-treatment system and tailpipe shall be outside the bus body compartment and shall be attached to the chassis so that any other chassis component is not damaged.
- B. The tailpipe and after-treatment system shall be constructed of a corrosion-resistant tubing material at least equal in strength and durability to 16-gauge steel tubing of equal diameter.
- C. The tailpipe may be flush with, or shall not extend more than two inches beyond, the perimeter of the body for side-exit pipe or the bumper for rear-exit pipe. The exhaust system shall be designed such that exhaust gas will not be trapped under the body of the bus.
- D. The tailpipe shall exit to the left or right of the emergency exit door in the rear of the vehicle or to the left side of the bus in front of or behind the rear drive axle or the tailpipe may extend through the bumper. The tailpipe exit location on all Types A-1 or B-1 buses may be in accordance to the manufacturer's standards. The tailpipe shall not exit beneath any fuel filler location, emergency door or lift door.
- E. The exhaust system shall be insulated in a manner to prevent any damage to any fuel system component.
- F. The design of the after-treatment systems shall not allow active (non-manual) regeneration of the particulate filter during the loading and unloading of passengers. Manual regeneration systems will be designed such that unintentional operation will not occur.
- G. For after treatment systems that require Diesel Exhaust Fluid (DEF) to meet federally mandated emissions:
 - 1. The composition of Diesel Exhaust Fluid (DEF) must comply with International Standard ISO 22241-1. Refer to engine manufacturer for any additional DEF requirements.
 - 2. The DEF supply tank shall be sized to meet a minimum ratio of 3 diesel fills to 1 DEF fill.
 - 3. (See lettering for DEF supply tank compartment under "IDENTIFICATION," this section.)

FENDERS: FRONT

- A. When measured at the fender line, the total spread of the outer edges of front fenders shall exceed the total spread of front tires when front wheels are in a straight-ahead position.
- B. Front fenders shall be properly braced and shall not require attachment to any part of the body.

FIRE SUPPRESSION SYSTEMS (OPTIONAL)

- A. A fire suppression system is recommended for installation in the engine compartment.
- B. The chassis manufacturer may provide an automatic fire extinguisher system in the engine compartment.
- C. Fire suppression system nozzles shall be located in the engine compartment, under the bus, in the electrical panel or under the dash, but they shall not be located in the passenger compartment. The system must include a lamp or buzzer to alert the driver that the system has been activated.

FLOORS

- A. The floor in the under-seat area, including tops of wheel housings, driver's compartment and toeboard, shall be covered with an elastomer floor covering, having a minimum overall thickness of .125 inch and a calculated burn rate of 0.1 mm per minute or less, using the test methods, procedures and formulas listed in FMVSS No. 302, *Flammability of Interior Materials*. The driver's area and toeboard area in all Type-A buses may be manufacturer's standard flooring and floor covering.
- B. The floor covering in the aisles shall be ribbed or other raised pattern elastomer and shall have a calculated burn rate of 0.1 mm per minute or less using the test methods, procedures and formulas listed in FMVSS No. 302. Minimum overall thickness shall be .187 inch measured from tops of ribs.

- C. The floor covering must be permanently bonded to the floor and must not crack when subjected to sudden changes in temperature. Bonding or adhesive material shall be waterproof and shall be a type recommended by the manufacturer of floor-covering material. All seams shall be sealed with waterproof sealer.
- D. On Types B, C and D buses, a flush-mounted, screw-down plate that is secured and sealed shall be provided to access the diesel or gasoline fuel tank sending unit and/or fuel pump. This plate shall not be installed under flooring material.

FRAME

- A. Frame lengths shall be established in accordance with the design criteria for the complete vehicle.
- B. Making holes in top or bottom flanges or side units of the frame and welding to the frame shall not be permitted except as provided or accepted by the chassis manufacturer.
- C. Frames shall not be modified for the purpose of extending the wheel base.
- D. Any secondary manufacturer that modifies the original chassis frame shall provide a warranty at least equal to the warranty offered by the original equipment manufacturer (OEM), and shall certify that the modification and other parts or equipment affected by the modification shall be free from defects in material and workmanship under normal use and service intended by the OEM.

FUEL SYSTEM

- A. Fuel tank(s) having a minimum 25-gallon capacity shall be provided by the chassis manufacturer. Each tank shall be filled from and vented to the outside of the passenger compartment, and each fuel filler should be placed in a location where accidental fuel spillage will not drip or drain on any part of the exhaust system.
- B. The fuel system shall comply with FMVSS No. 301, *Fuel System Integrity*.
- C. Fuel tank(s) may be mounted between the chassis frame rails or outboard of the frame rails on either the left or right side of the vehicle.
- D. The actual draw capacity of each fuel tank shall be a minimum of 83 percent of the tank capacity.
- E. Installation of alternative fuel systems, including fuel tanks and piping from the tank to the engine, shall comply with all applicable fire codes in effect on the date of manufacture of the bus.
- F. Installation of Liquefied Petroleum Gas (LPG) tanks shall comply with National Fire Protection Association (NFPA) 58, *Liquefied Petroleum Gas Code*.
- G. Installation of Compressed Natural Gas (CNG) containers shall comply with FMVSS No. 304, *Compressed Natural Gas Fuel Container Integrity*.
- H. The CNG Fuel System shall comply with FMVSS No. 303, *Fuel System Integrity of Compressed Natural Gas Vehicles*.

GOVERNOR

An electronic engine speed limiter shall be provided and set to limit engine speed, not to exceed the maximum revolutions per minute, as recommended by the engine manufacturer.

HANDRAILS

At least one handrail shall be installed. The handrail shall be a minimum of 1" diameter and be constructed from corrosion resistant material(s). The handrail(s) shall assist passengers during entry or exit and shall be designed to prevent entanglement, as evidenced by the passing of the NHTSA string and nut test.

HEATING SYSTEM, PROVISION FOR

The engine shall be capable of supplying coolant at a temperature of at least 170 degrees Fahrenheit at the engine coolant thermostat opening. The coolant flow rate shall be 50 pounds per minute at the return end of 30 feet of one inch inside diameter automotive hot water heater hose. (See SBMTC-001, *Standard Code for Testing and Rating Automotive Bus Hot Water Heating and Ventilating Equipment.*)

HEATING AND AIR CONDITIONING SYSTEMS

A. Heating System

1. The heater shall be hot water combustion type, electric heating element or heat pump.
2. If only one heater is used, it shall be fresh-air or combination fresh-air and recirculation type.
3. If more than one heater is used, additional heaters may be re-circulating air type.
4. The heating system shall be capable of maintaining bus interior temperatures, as specified in test procedure SAE J2233.
5. Auxiliary fuel-fired heating systems are permitted, provided they comply with the following:
 - a. The auxiliary heating system shall utilize the same type fuel as specified for the vehicle engine;
 - b. The heater(s) may be direct, hot air-type or may be connected to the engine coolant system;
 - c. An auxiliary heating system, when connected to the engine coolant system, may be used to preheat the engine coolant or preheat and add supplementary heat to the heating system;
 - d. Auxiliary heating systems must be installed pursuant to the manufacturer's recommendations and shall not direct exhaust in such a manner that will endanger bus passengers;
 - e. All combustion heaters shall be in compliance with current Federal Motor Carrier Safety Regulations;
 - f. The auxiliary heating system shall require low voltage.
 - g. Auxiliary heating systems shall comply with FMVSS No. 301, *Fuel System Integrity*, and all other applicable FMVSS, as well as with SAE test procedures.
6. All forced-air heaters installed by body manufacturers shall bear a name plate that indicates the heater rating in accordance with SBMTC-001, *Standard Code for Testing and Rating Automotive Bus Hot Water Heating and Ventilating Equipment*. The plate shall be affixed by the heater manufacturer and shall constitute certification that the heater performance is as shown on the plate.
7. Heater hoses shall be adequately supported to guard against excessive wear due to vibration. The hoses shall not dangle or rub against the chassis or any sharp edges and shall not interfere with or restrict the operation of any engine function. Heater hoses shall conform to SAE J20c, *Coolant System Hoses*. Heater lines, cores, and elements on the interior of the bus shall be shielded to prevent scalding or burning of the driver or passengers.
8. Each hot water system installed by a body manufacturer shall include one shutoff valve in the pressure line and one shut-off valve in the return line, with both valves at the engine in an accessible location, except that on Types A and B buses, the valves may be installed in another accessible location.
9. All heaters of hot water type in the passenger compartment shall be equipped with a device, installed in the hot water pressure line, which regulates the water flow to all passenger heaters.

The device shall be conveniently operated by the driver while seated. The driver and passenger heaters may operate independently of each other for maximum comfort.

10. On hot water type systems, accessible bleeder valves for removing air from the heater shall be installed in an appropriate place in the return lines of body company-installed heater.
11. Access panels shall be provided to make heater motors, cores, elements and fans readily accessible for service. An exterior access panel to the driver's heater may be provided.

B. Passenger Compartment Air Conditioning (Optional)

The following specifications are applicable to all types of school buses that may be equipped with air conditioning. This section is divided into three parts. Part 1 covers performance specifications, Part 2 covers test conditions and Part 3 covers other requirements applicable to all buses.

1. Performance Specifications

a. Standard Performance

The installed air conditioning system should cool the interior of the bus from 100 degrees to 80 degrees Fahrenheit, measured at three points (minimum) located four feet above the floor on the longitudinal centerline of the bus. The three required points shall be: (1) three feet above the center point of the horizontal driver seat surface, (2) at the longitudinal midpoint of the body, and (3) three feet forward of the rear emergency door or, for Type D rear-engine buses, three feet forward of the end of the aisle. Note for the Type A vehicles placement of the rear thermocouple should be centered in the bus over the rear axle. The independent temperature reading of each temperature probe inside the bus shall be within a range of ± 3 degrees Fahrenheit of the average temperature at the conclusion of the test.

b. High Performance

The installed air conditioning system should cool the interior of the bus from 100 degrees to 70 degrees Fahrenheit, measured at three points (minimum) located four feet above the floor on the longitudinal centerline of the bus. The three required points shall be: (1) three feet above the center point of the horizontal driver seat surface, (2) at the longitudinal midpoint of the body, and (3) three feet forward of the rear emergency door or, for Type D rear-engine buses, three feet forward of the end of the aisle. Note for the Type A vehicles placement of the rear thermocouple should be centered in the bus over the rear axle. The independent temperature reading of each temperature probe inside the bus shall be within a range of ± 3 degrees Fahrenheit of the average temperature at the conclusion of the test.

2. Test Conditions

The test conditions under which the above performance standards must be achieved shall consist of (1) placing the bus in a room (such as a paint booth) where ambient temperature can be maintained at 100 degrees Fahrenheit; (2) heat-soaking the bus at 100 degrees Fahrenheit at a point measured two feet horizontally from the top of the windows on both sides of the bus, with windows open for two hours; and (3) closing windows, turning on the air conditioner with the engine running at 1250 ± 50 RPM, and cooling the interior of the bus to 80 degrees Fahrenheit, (standard performance) or 70 degrees Fahrenheit (high performance), within 30 minutes while maintaining 100 degrees Fahrenheit outside temperature.

The manufacturer shall provide test results that show compliance with standard systems. If the bid specifies, the manufacturer shall provide facilities for the user or user's representative to confirm that a pilot model of each bus design meets the above performance requirements.

3. Other Requirements

- a. Evaporator cases, lines and ducting (as equipped) shall be designed in such a manner that all condensation is effectively drained to the exterior of the bus below the floor level under all conditions of vehicle movement and without leakage on any interior portion of the bus;
- b. Evaporators and ducting systems shall be designed and installed to be free of projections or sharp edges. Ductwork shall be installed so that exposed edges face the front of the bus and do not present sharp edges;
- c. On school buses equipped with Type-2 seatbelts having anchorages above the windows, the ducting (if used) shall be placed at a height sufficient to not obstruct occupant securement anchorages. This clearance shall be provided along the entire length (except at evaporator locations) of the passenger area on both sides of the bus interior;
- d. The body may be equipped with insulation, including sidewalls, roof, firewall, rear, inside body bows and plywood or composite floor insulation to reduce thermal transfer;
- e. All glass (windshield, service and emergency doors, side and rear windows) may be equipped with maximum integral tinting allowed by federal, state or ANSI standards for the respective locations, except that windows rear of the driver's compartment, if tinted, shall have approximately 28 percent light transmission;
- f. Electrical generating capacity shall be provided to accommodate the additional electrical demands imposed by the air conditioning system;
- g. Roofs may be painted white to aid in heat dissipation (See Appendix B).
- h. Air intake for any evaporator assembly(ies), except for front evaporator of Type A-1, shall be equipped with replaceable air filter(s) accessible without disassembly of evaporator case.
- i. For all buses (except Type D rear engine transit) equipped with a rear evaporator assembly, evaporator shall not encroach upon head impact zone, but may occupy an area of less than 26.5 inches from the rear wall and 14 inches from the ceiling.
- j. For Type D rear engine transit buses equipped with a rear evaporator over the davenport, the evaporator assembly may not interfere with rear exit window and may not extend above the rear seating row.

HINGES

All exterior metal door hinges shall be designed to allow lubrication to be channeled to the center 75% of each hinge loop without disassembly, unless they are constructed of stainless steel, brass or non-metallic hinge pins or other designs that prevent corrosion.

HORN

The bus shall be equipped with a horn(s) of standard make with the horn(s) capable of producing a complex sound in bands of audio frequencies between 250 and 2,000 cycles per second, and tested in accordance with SAE J377, *Horn—Forward Warning— Electric—Performance, Test, and Application*.

IDENTIFICATION

- A. The body shall bear the words “SCHOOL BUS” in black letters at least eight inches high on both front and rear of the body or on signs attached thereto. Lettering shall be placed as high as possible without impairment of its visibility. Letters shall conform to “Series B” of Standard Alphabets for Highway Signs. “SCHOOL BUS” lettering shall have a reflective background, or as an option, may be illuminated by backlighting.
- B. Required lettering and numbering shall include:
 - 1. District or school(s) name(s) displayed at the beltline **in letters that are a minimum of 5 inches in height.**
 - 2. Company name or owner of the bus displayed below the driver’s side window.
 - 3. The bus identification number displayed on the sides, on the rear and on the front.
 - 4. Exterior firearm-free zone sign displayed to the left of the entrance door. (R.S. 14:95.6)
 - 5. Exterior drug-free zone sign displayed to the left of the entrance door. (R.S. 40:981.3)
 - 6. Mandatory signage described in B.4 and B.5 (above) may be combined into one sign.
- C. Other lettering, numbering or symbols that may be displayed on the exterior of the bus shall be limited to:
 - 1. Bus identification number, minimum 12-inch high characters, on top of the bus, in addition to required numbering on the sides, rear and front;
 - 2. The location of the battery(ies) identified by the word “BATTERY” or “BATTERIES” on the battery compartment door in two-inch lettering;
 - 3. Symbols or letters not to exceed 64 square inches of total display near the entrance door, displaying information for identification by the students of the bus or route served;
 - 4. Manufacturer, dealer or school identification or logos;
 - 5. Symbols identifying the bus as equipped for or transporting students with special needs as noted in SPECIALLY EQUIPPED SCHOOL BUS SPECIFICATIONS;
 - 6. Electronic warning sign related to school bus flashing signal;
 - 7. Lettering relating to railroad stop procedures; and
 - 8. Identification of fuel type in 1-inch lettering adjacent to the fuel filler opening.
 - 9. Manufacturer’s identification of DEF compartment, if applicable.

INSIDE HEIGHT

Inside body height shall be 72 inches or more, measured metal to metal, at any point on the longitudinal centerline from the front vertical bow to the rear vertical bow. Inside body height of Type A-1 buses shall be 62 inches or more. Inside height measurement does not apply to air conditioning equipment.

INSTRUMENTS AND INSTRUMENT PANEL

A. The chassis shall be equipped with the instruments and gauges listed below:

Note: Telltale warning lamps in lieu of gauges are not acceptable, except as noted.

1. Speedometer;
2. Odometer that can be read without using a key and that will give accrued mileage (to seven digits), including tenths of miles, unless tenths of miles are registered on a trip odometer;
3. Tachometer;
Note: For types B, C and D buses, a tachometer shall be installed so as to be visible to the driver while seated in a normal driving position.
4. Voltmeter;
Note: An ammeter with graduated charge and discharge indications is permitted in lieu of a voltmeter; however, when used, the ammeter wiring must be compatible with the current flow of the system.
5. Oil pressure gauge;
6. Water temperature gauge;
7. Fuel gauge;
8. High beam headlamp indicator;
9. Brake air pressure gauge (air brakes), brake indicator lamp (vacuum/hydraulic brakes), or brake indicator lamp (hydraulic/hydraulic);
10. Turn signal indicator; and
11. Glow-plug indicator lamp, where appropriate.

B. All instruments shall be easily accessible for maintenance and repair.

C. The instruments and gauges shall be mounted on the instrument panel so that each is clearly visible to the driver while seated in a normal driving position.

D. Instruments and controls must be illuminated as required by FMVSS No. 101, *Controls and Displays*.

E. Multi-Function Gauge (MFG)

1. The driver must be able to manually select any displayable function of the gauge on a MFG, whenever desired.
2. Whenever an out-of-limits condition that would be displayed on one or more functions of a MFG occurs, the MFG controller should automatically display this condition on the instrument cluster. This should be in the form of an illuminated telltale warning lamp, as well as having the MFG automatically display the out-of-limits indications. If two or more functions displayed on the MFG go out of limits simultaneously, then the MFG should sequence automatically between those functions continuously until the condition(s) are corrected.
3. The use of a MFG does not relieve the need for audible warning devices, where required.

INSULATION (OPTIONAL)

A. If thermal insulation is specified, it shall be fire-resistant (FMVSS 302), with a minimum R-value of 5.5. Insulation shall be installed so as to prevent sagging.

B. If floor insulation is required, it shall be five-ply softwood plywood, nominal $\frac{5}{8}$ -inch thickness and shall be equal to or exceed properties of the exterior-type, C-D Grade, as specified in the standard issued by U.S. Department of Commerce. When plywood is used, all exposed edges shall be sealed. Type A-1 buses may be equipped with nominal $\frac{1}{2}$ -inch-thick plywood or equivalent material meeting the above requirements.

Equivalent material may be used to replace plywood, provided it has equal or greater insulation R-value, sound abatement, deterioration-resistant and moisture-resistant properties.

INTERIOR

- A. The interior of the bus shall be free of all unnecessary projections, which include luggage racks and attendant handrails, to minimize the potential for injury. This specification requires inner lining on ceilings and walls. If the ceiling is constructed with lap joints, the forward panel shall be lapped by rear panel and exposed edges shall be beaded, hemmed, flanged or otherwise treated to minimize sharp edges. Buses may be equipped with a storage compartment for tools, tire chains and/or tow chains. (See STORAGE COMPARTMENT, this section.)
- B. Interior overhead storage compartments may be provided if they meet the following criteria:
 - 1. Head protection requirements of FMVSS No. 222, *School Bus Passenger Seating and Crash Protection*, where applicable;
 - 2. Be completely enclosed and equipped with latching door (both door and latch sufficient to withstand a pushing force of 50 pounds applied at the inside center of the door);
 - 3. Have all corners and edges rounded with a minimum radius of one inch or be padded equivalent to door header padding;
 - 4. Be attached to the bus sufficiently to withstand a force equal to 20 times the maximum rated capacity of the compartment; and
 - 5. Have no protrusions greater than $\frac{1}{4}$ inch.
- C. The driver's area forward of the foremost padded barriers will permit the mounting of required safety equipment and vehicle operation equipment.
- D. Every school bus shall be constructed so that the noise level at the ear of the occupant nearest to the primary vehicle noise source shall not exceed 85 dBA when tested according to the procedure described in Appendix B.

LAMPS AND SIGNALS

- A. Interior lamps which illuminate the aisle and the stepwell shall be provided. The stepwell lamp shall be illuminated by an entrance door-operated switch, to illuminate only when headlamps and clearance lamps are on and the entrance door is open.
- B. Body instrument panel lamps may be controlled by an independent dimmer switch or may be controlled by the dimmer that operates the gauge lighting.
- C. School bus alternately flashing signal lamps shall be provided, as described by R.S. 32:289.
 - 1. The bus shall be equipped with two red lamps at the rear of the vehicle and two red lamps at the front of the vehicle.
 - 2. In addition to the four red lamps described above, four amber lamps shall be installed so that one amber lamp is located near each red signal lamp, at the same level, but closer to the vertical centerline of the bus. The system of red and amber signal lamps shall be wired so that amber lamps are energized manually. The red lamps are automatically energized and amber lamps are automatically de-energized when stop signal arms and the crossing control arm are extended or when the bus entrance door is opened.

The above-mentioned activation sequence can be accomplished with either a "sequential operation" or a "non-sequential operation" warning lamp system. While each of the systems can be configured to include components such as a master switch, amber activation switch, interrupt switch, etc., the presence (or absence) of these components does not affect the classification of the system as either *sequential* or *non-sequential*. Both *sequential* and *non-sequential* systems can be configured with a multitude of switch combinations to provide a unique system meeting specific user requirements. An amber pilot lamp and a red pilot lamp shall be installed adjacent to the driver controls for the flashing signal lamp to indicate to the driver which lamp system is activated.

3. If air or electric doors are used, the amber lights shall be activated from a momentary switch. A Three position switch shall activate the sequence as follows:
 - a. Position one—Door closed; lights off.
 - b. Position two—Activate red lights, stop arm and crossing control arm.
 - c. Position three—Red lights activated, door open, stop arm activated and crossing control arm activated.
 4. Background color may be SBY or glossy black.
 5. Red lamps shall flash at any time the stop signal arm is extended.
 6. All flashers for alternately flashing red and amber signal lamps shall be enclosed in the body in a readily accessible location.
- D. Turn signal and stop/tail lamps
1. The bus body shall be equipped with amber rear turn signal lamps that are at least seven inches in diameter or, if a shape other than round, a minimum 38 square inches of illuminated area and shall meet FMVSS No. 108, *Lamps, Reflective Devices, and Associated Equipment*. These signal lamps must be connected to the chassis hazard warning switch to cause simultaneous flashing of turn signal lamps when needed as a vehicular traffic hazard warning. Turn signal lamps are to be placed as wide apart as practical and their horizontal centerline shall be a maximum of 12 inches below the rear window.
 2. Buses shall be equipped with amber side-mounted turn signal lamps. The turn signal lamp on the left side shall be mounted rearward of the stop signal arm and the turn signal lamp on the right side shall be mounted rearward of the entrance door.
 3. Buses shall be equipped with four combination red stop/tail lamps.
 - a. Two combination lamps with a minimum diameter of seven inches, or if a shape other than round, a minimum 38 square inches of illuminated area shall be mounted on the rear of the bus just inside the turn signal lamps
 - b. Two combination lamps with a minimum diameter of four inches, or if a shape other than round, a minimum of 12 square inches of illuminated area, shall be placed on the rear of the body between the beltline and the floor line. The rear license plate lamp may be combined with one lower tail lamp. Stop lamps shall be activated by the service brakes and shall emit a steady light when illuminated.
- E. On buses equipped with a monitor for the front and rear lamps of the school bus, the monitor shall be mounted in full view of the driver. If the full circuit current passes through the monitor, each circuit shall be protected against any short circuit or intermittent shorts by a fuse circuit breaker, or electronic protection device.
- F. An optional white flashing strobe lamp may be installed on the roof of a school bus at a location not closer than 12 inches or more than 6 feet from the rear of the roof edge. However, if the bus is equipped with a roof hatch or other roof mounted equipment falling within the above-mentioned measurements, the strobe lamp may be located directly behind that equipment. The lamp shall have a single clear lens emitting light 360 degrees around its vertical axis, meeting the requirements of SAE J845. It may not extend above the roof more than the maximum legal height. A manual switch and a pilot lamp shall be included to indicate when the lamp is in operation. Optionally, the strobe lamp may be wired to activate with the amber alternately flashing signal lamps, continuing through the full loading or unloading cycle, and may be equipped with an override switch to allow activation of the strobe at any time for use in inclement weather.
- G. The bus body shall be equipped with two white rear backup lamps that are at least four inches in diameter or, if a shape other than round, a minimum of 12 square inches of illuminated area, and shall meet FMVSS No. 108. If backup lamps are placed on the same horizontal line as the brake

lamps and turn signal lamps, they shall be to the inside.

- H. Clearance, identification and side marker lamps and reflectors shall comply with Louisiana R.S. 32:308.A. and F, R.S. 32:309, 32:310 and 32:311.
- I. A daytime-running-lamps (DRL) system shall be provided.

METAL TREATMENT

- A. All metal except high-grade stainless steel or aluminum used in construction of the bus body shall be zinc-coated or aluminum-coated or treated to prevent corrosion. This includes but is not limited to such items as structural members, inside and outside panels, door panels and floor sills. Excluded are such items as door handles, grab handles, interior decorative parts and other interior plated parts.
- B. All metal parts that will be painted, in addition to the above requirements, shall be chemically cleaned, etched, zinc phosphate-coated and zinc chromate- or epoxy-primed to improve paint adhesion. This includes, but is not limited to, such items as crossing control arm and stop arm.
- C. In providing for these requirements, particular attention shall be given to lapped surfaces, welded connections of structural members, cut edges on punched or drilled hole areas in sheet metal, closed or box sections, unvented or undrained areas and surfaces subjected to abrasion during vehicle operation.
- D. As evidence that the above requirements have been met, samples of materials and sections used in the construction of the bus body shall be subjected to a cyclic corrosion testing as outlined in SAE J1563.

MIRRORS

- A. The interior glass mirror shall be either laminated or tempered and shall have rounded corners and protected edges. Mirrors shall be 6x16 inches minimum for Type A buses and be 6x30 inches minimum for Types C and D buses.
- B. Each school bus shall be equipped with exterior mirrors meeting the requirements of FMVSS No. 111, *Rearview Mirrors*. The right side, rear view mirror shall not be obscured by the unwiped portion of the windshield. Mirrors shall be easily adjustable, but shall be rigidly braced, so as to reduce vibration.
- C. Heated external mirrors may be used.
- D. Remote controlled external rear view mirrors may be used.

MOUNTING

- A. The rear body cross member shall be supported by the chassis frame. Except where chassis components interfere, the bus body shall be attached to the chassis frame at each main floor sill in such a manner as to prevent shifting or separation of the body from the chassis under severe operating conditions.
- B. Isolators shall be installed at all contact points between the body and the chassis frame on Types A-2, B, C and D buses, and shall be secured by a positive means to the chassis frame or body to prevent shifting, separation, or displacement of the isolators under severe operating conditions.

MUD GUARDS (MUD FLAPS)

Mud guards shall be rubber and meet requirements of R.S. 32:364. Mud guards shall be at least the width of the vehicle's tires.

OIL FILTER

An oil filter with a replaceable element shall be provided and connected by flexible oil lines if it is not

a built-in or an engine-mounted design. The oil filter shall have a capacity in accordance with the engine manufacturer's recommendation.

OPENINGS

All openings in the floorboard or firewall between the chassis and the passenger compartment (e.g., for gearshift selector and parking brakes lever) shall be sealed.

OVERALL LENGTH

Overall length of the bus shall not exceed 45 feet, excluding accessories.

OVERALL WIDTH

Overall width of bus shall not exceed 102 inches, excluding accessories.

PASSENGER LOAD

- A. Actual gross vehicle weight (GVW) is the sum of the chassis weight plus the body weight, plus the driver's weight, plus total seated student weight. For purposes of calculation, the driver's weight is 150 pounds and the student weight is 120 pounds per student.
- B. Actual GVW shall not exceed the chassis manufacturer's GVWR for the chassis, nor shall the actual weight carried on any axle exceed the chassis manufacturer's Gross Axle Weight Rating (GAWR).

PUBLIC ADDRESS SYSTEM (OPTIONAL)

- A. Buses may be equipped with an AM/FM/audio and/or public address system having interior and exterior speakers.
- B. No internal speakers, other than the driver's communication systems, may be installed within four feet of the driver's seat back in its rearmost upright position.

RETARDER SYSTEM (OPTIONAL EQUIPMENT)

A retarder system, if used, shall limit the speed of a fully loaded school bus to 19.0 mph on a 7% grade for 3.6 miles.

RETROREFLECTIVE MATERIAL

(See also Appendices A and B, [Retroreflective Sheeting](#).)

- A. The front and/or rear bumper may be marked diagonally 45 degrees down toward the centerline of the pavement with two $\pm \frac{1}{4}$ inch-wide strips of non-contrasting retroreflective material.
- B. The rear of the bus body shall be marked with strips of retroreflective NSBY material to outline the perimeter of the back of the bus using material which conforms with the requirements of FMVSS No. 131, *School Bus Pedestrian Safety Devices*, Table 1. The perimeter marking of rear emergency exits per FMVSS No. 217, *Bus Emergency Exits and Window Retention and Release*, and/or the use of retroreflective "SCHOOL BUS" signs partially accomplishes the objective of this requirement. To complete the perimeter marking of the back of the bus, strips of retroreflective NSBY material, a minimum of 1 inch and a maximum of 2 inches in width shall be applied horizontally above the rear windows and above the rear bumper, extending from the rear emergency exit perimeter, marking outward to the left and right rear corners of the bus. Vertical strips shall be applied at the corners connecting these horizontal strips. Multifunction school activity buses (MFSABs) shall be exempt from these color requirements.
- C. "SCHOOL BUS" signs, if not a lighted design, shall be marked with retroreflective NSBY material

comprising background for lettering of the front and/or rear “SCHOOL BUS” signs.

- D. Sides of the bus body shall be marked with at least 1¾ inch retroreflective NSBY material, extending the length of the bus body and located (vertically) between the floor line and the beltline.

ROAD SPEED CONTROL

When it is desired to accurately control vehicle maximum speed, a vehicle speed limiter may be utilized.

RUB RAILS

- A. There shall be one rub rail on each side of the bus located at, or no more than eight inches above, the seat cushion level. They shall extend from the rear side of the entrance door completely around the bus body (except at the emergency door or any maintenance access door) to the point of curvature near the outside cowl on the left side.
- B. There shall be one additional rub rail on each side located 10 inches or less above the floor line. The rub rail shall cover the same longitudinal span as the upper rub rail, except at the wheel housing, and it shall extend only to the longitudinal tangent of the right and left rear corners.
- C. Rub rails above the floor line shall be attached at each body post and at all other upright structural members.
- D. Each rub rail shall be four inches or more in width in its finished form and shall be constructed of 16-gauge metal or other material of equivalent strength suitable to help protect body side panels from damage. Rub rails shall be constructed in corrugated or ribbed fashion.
- E. Rub rails shall be applied outside the body or outside the body posts. (Pressed-in or snap-on rub rails do not satisfy this requirement.) For Type A-1 vehicles using the body provided by the chassis manufacturer or for Types A-2, B, C and D buses containing the rear luggage or the rear engine compartment, rub rails need not extend around the rear corners.
- F. The bottom edge of the body side skirts shall be stiffened by application of a rub rail, or the edge may be stiffened by providing a flange or other stiffeners.
- G. Rub rails shall be painted glossy black.

SEATS AND RESTRAINING BARRIERS

- A. Passenger Seating
 1. School bus design capacities shall be in accordance with 49 CFR, Part 571.3, *Definitions*, and FMVSS No. 222, *School Bus Passenger Seating and Crash Protection*.
 2. All seats shall have a minimum cushion depth of 15 inches, a seat back height of 24 inches above the seating reference point, and must comply with all other requirements of FMVSS No. 222.
 3. All restraining barriers and passenger seats shall be constructed with materials that enable them to meet the criteria of the *School Bus Seat Upholstery Fire Block Test*.
 4. Each seat leg shall be secured to the floor by bolts, washers and nuts in order to meet the performance requirements of FMVSS No. 222. Flange-head nuts may be used in lieu of nuts and washers. All seat frames attached to the seat rail shall be fastened with two or more bolts, washers and nuts, or with flange-head nuts. Seats may be track-mounted in conformance with FMVSS No. 222.
 5. If track seating is installed, the manufacturer shall supply minimum and maximum seat spacing dimensions (applicable to the bus) which comply with FMVSS No. 222. This information shall be on a label permanently affixed to the bus.

6. All school buses (including Type A) shall be equipped with restraining barriers which conform to FMVSS No. 222.
7. A flip-up seat may be installed at any side emergency door. If provided, the flip-up seat shall conform to FMVSS No. 222 and aisle clearance requirements of FMVSS No. 217, *Bus Emergency Exits and Window Retention and Release*. The flip-up seat shall be free of sharp projections on the underside of the seat bottom. The underside of the flip-up seat bottoms shall be padded or contoured to reduce the possibility of clothing being snagged. Flip-up seats shall be constructed to prevent passenger limbs from becoming entrapped between the seat back and the seat cushion when the seat is in the upright position. The seat cushion shall be designed to rise to a vertical position automatically when it is not occupied.
8. Lap belts shall not be installed on passenger seats in large school buses (over 10,000 pounds GVWR) except in conjunction with child safety restraint systems that comply with the requirements of FMVSS No. 213, *Child Restraint Systems*.

B. Pre-School Age Seating

Passenger seats designed to accommodate a child or infant carrier seat shall comply with FMVSS No. 225, *Child Restraint Anchorage Systems*. These seats shall be in compliance with NHTSA's "Guideline for the Safe Transportation of Pre-school Age Children in School Buses."

Note: See A.8, above.

C. Driver Seat

1. The driver's seat supplied by the body manufacturer shall be a high back seat. The seat back shall be adjustable to 15 degrees minimum, without requiring the use of tools. The seat shall be equipped with a head restraint to accommodate a 5th percentile female to a 95th percentile adult male, as defined in FMVSS No. 208, *Occupant Crash Protection*.
2. Type A buses may utilize the standard driver's seat provided by the chassis manufacturer.

D. Driver Restraint System

A Type 2 lap/shoulder belt shall be provided for the driver. On buses where the driver's seat and upper anchorage for the shoulder belt are both attached to the body structure, a driver's seat with an integrated Type 2 lap/shoulder belt may be substituted. On buses where the driver's seat and upper anchorage for the shoulder belt are separately attached to both body and chassis structures (i.e., one attached to the chassis and the other attached to the body), a driver's seat with an integrated Type 2 lap/shoulder belt should be used.

The assembly shall be equipped with an emergency locking retractor for the continuous belt system. On all buses except Type A that are equipped with a standard chassis manufacturer's driver's seat, the lap portion of the belt system shall be guided or anchored to prevent the driver from sliding sideways under the belt system. The lap/shoulder belt shall be designed to allow for easy adjustment in order to fit properly and to effectively protect drivers varying in size from 5th percentile adult female to 95th percentile adult male. The belt may be of a high visibility contrasting color.

- E. Each bus shall be equipped with a durable webbing cutter having a full width handgrip and a protected, replaceable or non-corrodible blade. The required webbing cutter shall be mounted in a location accessible to the seated driver in an easily detachable manner.

SHOCK ABSORBERS

The bus shall be equipped with double-action shock absorbers compatible with the manufacturer's rated axle capacity at each wheel location.

SIDE SKIRTS

School bus body side skirts between the front and rear axles shall extend down to within two inches, plus or minus, of the horizontal line from the center of the front spindle to the center of the rear axle. The manufacturer may offer optional side skirt lengths that extend lower than this requirement. This measurement shall apply to a new unloaded school bus located on a flat, level surface.

STEERING GEAR

- A. The steering gear shall be approved by the chassis manufacturer and designed to ensure safe and accurate performance when the vehicle is operated with maximum load and at maximum speed.
- B. If external adjustments are required, the steering mechanism shall be accessible to make adjustments.
- C. Changes shall not be made to the steering apparatus which are not approved by the chassis manufacturer.
- D. There shall be a clearance of at least two inches between the steering wheel and cowl, instrument panel, windshield or any other surface.
- E. Power steering is required and shall be of the integral type with integral valves.
- F. The steering system shall be designed to provide a means for lubrication of all wear-points that are not permanently lubricated.

STEPS

- A. The first step at the entrance door shall be not less than 10 inches and not more than 14 inches from the ground when measured from the top surface of the step to the ground, based on standard chassis specifications, except that on Type D vehicles, the first step at the entrance door shall be 12 inches to 16 inches from the ground. An auxiliary step may be provided to compensate for the increase in ground-to-first-step clearance. The auxiliary step is not required to be enclosed.
- B. Step risers shall not exceed a height of 10 inches.

Note: When plywood is used on a steel floor or step, the riser height may be increased by the thickness of the plywood.

- C. Steps shall be enclosed to prevent accumulation of ice and snow.
- D. Steps shall not protrude beyond the side body line.

STEP TREADS

- A. All steps, including the floor line platform area, shall be covered with an elastomer floor covering having a minimum overall thickness of 0.187 inch.
- B. The step covering shall be permanently bonded to a durable backing material that is resistant to corrosion.
- C. Steps, including the floor line platform area, shall have a 1 ½-inch nosing that contrasts in color by at least 70 percent measured in accordance with the contrasting color specification in 36 CFR, Part 1192, ADA, *Accessibility Guidelines for Transportation Vehicles*.
- D. Step treads shall have the following characteristics:
 - 1. Abrasion resistance: Step tread material weight loss shall not exceed 0.40 percent, as tested under ASTM D-4060, *Standard Test Method for Abrasion Resistance of Organic Coatings by the Taber Abraser*, (CS-17 Wheel, 1000- gram, 1000 cycle).
 - 2. Weathering resistance: Step treads shall not break, crack, or check after ozone exposure (seven days at 50 pphm at 40 degrees C) and Weatherometer exposure (ASTM D-750, *Standard Test Method for Rubber Deterioration in Carbon-Arc Weathering Apparatus*, seven days).

3. Flame resistance: Step treads shall have a calculated burn rate of .01 mm per minute or less using the test methods, procedures and formulas listed in FMVSS No. 302, Flammability of Interior Materials.

Note: A spray on application type material may be used in lieu of item A. that meets the requirements of items B. through D. The material shall be applied not only to the interior surfaces of the service door step treads but also to the exterior, if not covered by undercoating.

STIRRUP STEPS

If the windshield and lamps are not easily accessible from the ground, there may be at least one folding stirrup step or recessed foothold installed on each side of the front of the body for easy accessibility for cleaning. There also may be a grab handle installed in conjunction with the step. Steps are permitted in or on the front bumper in lieu of the stirrup steps if the windshield and lamps are easily accessible for cleaning from that position.

STOP SIGNAL ARM

The stop signal arm(s) shall comply with the requirements of FMVSS No. 131, *School Bus Pedestrian Safety Devices* and with RS 32: 318.

STORAGE COMPARTMENT (OPTIONAL)

A storage container for tools, tire chains and/or other equipment may be located either inside or outside the passenger compartment. If inside, the storage compartment shall be fastened to the floor and have a cover with a positive fastening device, and chemicals shall not be stored in interior storage compartment.

SUN SHIELD

- A. On Types B, C and D vehicles, an interior adjustable transparent sun shield, with a finished edge and dimensions not less than 6x30 inches, shall be installed in a position convenient for use by the driver.
- B. On Type A buses, the sun shield (visor) shall be installed by the chassis manufacturer.

SUSPENSION SYSTEMS

- A. The capacity of springs or suspension assemblies shall be commensurate with the chassis manufacturer's GVWR.
- B. Rear leaf springs shall be of a progressive rate or multi-stage design. Front leaf springs shall have a stationary eye at one end and shall be protected by a wrapped leaf, in addition to the main leaf.

THROTTLE

The force required to operate the throttle shall not exceed 16 pounds throughout the full range of accelerator pedal travel.

TIRES AND RIMS

- A. Rims and tires of the proper size and load rating commensurate with the chassis manufacturer's GVWR shall be provided. The use of multi-piece rims and/or tube-type tires shall not be permitted on any school bus initially placed into service to transport students to and from Louisiana school after December 31, 1995.
- B. Dual rear tires shall be provided on Type A-2, Type B, Type C and Type D school buses.

- C. All tires on a vehicle shall be of the same size, and the load range of the tires shall meet or exceed the GVWR, as required by FMVSS No. 120, *Tire Selection and Rims for Vehicles other than Passenger Car*.
- D. If the vehicle is equipped with a spare tire and rim assembly, it shall be the same size as those mounted on the vehicle.
- E. If a tire carrier is required, it shall be suitably mounted in an accessible location outside of the passenger compartment.

TOWING ATTACHMENT POINTS

Front and/or rear towing devices (i.e., tow hooks, tow eyes, or other designated towing attachment points) shall be furnished to assist in the retrieval of buses that are stuck and/or for towing buses when a tow truck with a “wheel lift” or an “axle lift” is not available or cannot be applied to the towed vehicle.

- A. Towing devices shall be attached to the chassis frame either by the chassis manufacturer or in accordance with the chassis manufacturer’s specifications.
- B. Each towing device shall have a strength rating of 13,500 pounds each, for a combined rating of 27,000 pounds with the force applied in the rearward direction, parallel to the ground, and parallel to the longitudinal axis of the chassis frame rail. For pulling and lifting purposes, tow hooks are meant to be used simultaneously. For pulling, angularity applied to the tow hooks will decrease the capacities of the tow hooks.
- C. The towing devices shall be mounted such that they do not project forward of the front bumper or rearward of the rear bumper.

Note: Type A buses are exempt from the requirement for front tow hooks or eyes due to built-in crush zones.

TRACTION ASSISTING DEVICES (OPTIONAL)

- A. Where required or used, sanders shall:
 - 1. Be hopper cartridge-valve type;
 - 2. Have a metal hopper with all interior surfaces treated to prevent condensation of moisture;
 - 3. Have at least 100 pounds (grit) capacity;
 - 4. Have a cover that screws in place on the filler opening of the hopper, thereby sealing the unit airtight;
 - 5. Have discharge tubes extending under the fender wheelhousing to the front of each rear wheel;
 - 6. Have non-clogging discharge tubes with slush-proof, non-freezing rubber nozzles;
 - 7. Be operated by an electric switch with a pilot lamp mounted on the instrument panel located so as to be exclusively controlled by the driver;
 - 8. Be equipped with a gauge to indicate that the hopper has reached the one-quarter level (and needs to be refilled); and
 - 9. Be designed to prevent freezing of all activation components and moving parts.
- B. Automatic traction chains may be installed.

TRANSMISSION

- A. Automatic transmissions shall have no fewer than three forward speeds and one reverse speed. Mechanical shift selectors shall provide a detent between each gear position when the gear selector quadrant and shift selector are not steering-column mounted.
- B. Automatic transmissions shall have a transmission shifter interlock controlled by the application of the service brake to prohibit accidental engagement of the transmission.

TRASH CONTAINER AND HOLDING DEVICE (OPTIONAL)

When requested or used, the trash container shall be secured by a holding device that is designed to prevent movement and to allow easy removal and replacement. It shall be installed in an accessible location **in the driver's compartment**, not obstructing passenger access to the entrance door.

TURNING RADIUS

- A. A chassis with a wheelbase of 264 inches or less shall have a right and left turning radius of not more than 42 ½ feet, curb-to-curb measurement.
- B. A chassis with a wheelbase of 265 inches or more shall have a right and left turning radius of not more than 44 ½ feet, curb-to-curb measurement.

UNDERCOATING

- A. The entire underside of the bus body, including floor sections, cross member and below floor-line side panels, shall be coated with rust-proofing material for which the material manufacturer has issued to the bus body manufacturer a notarized certification to the bus body manufacturer that materials meet or exceed all performance requirements of SAE J1959, Sept. 2003 Edition of the Standard.
- B. The undercoating material shall be applied with suitable airless or conventional spray equipment to the undercoating material manufacturer recommended film thickness and shall show no evidence of voids in the cured film.
- C. The undercoating material shall not cover any exhaust components of the chassis.

VENTILATION

- A. Auxiliary Fan(s) shall meet the following requirements:
- B. Fan(s) shall be placed in a location where they can be adjusted for maximum effectiveness and where they do not obstruct the driver's vision to the mirrors or interfere with the safe operation of the vehicle.
 - 1. Fans shall have six-inch (nominal) diameter.
 - 2. Fan blades shall be enclosed in a protective cage. Each fan shall be controlled by a separate switch.
- C. The bus body shall be equipped with a suitably controlled ventilating system with capacity sufficient to maintain the proper quantity of air flow under operating conditions without having to open a window except in extremely warm weather.
- D. Static-type, non-closeable exhaust ventilation shall be installed in a low-pressure area of the roof.
- E. Roof hatches designed to provide ventilation in all types of exterior weather conditions may be provided.

WHEELHOUSING

- A. The wheelhousing opening shall allow for easy tire removal and service.
- B. Wheel housings shall be attached to the floor panels in a manner to prevent any dust, water or fumes from entering the body. Wheel housings shall be constructed of 16- gauge (or thicker) steel.
- C. The inside height of the wheel housings above the floor line shall not exceed 12 inches.
- D. The wheel housings shall provide clearance for installation and use of tire chains on single or dual (if so equipped) power-driving wheels.
- E. No part of a raised wheelhousing shall extend into the emergency door opening.

WINDOWS

- A. Other than emergency exits designated to comply with FMVSS No. 217, *Bus Emergency Exits and Window Retention and Release*, each side window shall provide an unobstructed opening of at least nine inches high (but not more than 13 inches high) and at least 22 inches wide, obtained by lowering the window. One window on each side of the bus may be less than 22 inches wide.
- B. All glass (windshield, service and emergency doors, side and rear windows) may be equipped with maximum integral tinting allowed by federal, Louisiana (RS 32:361.1) or ANSI standards for the respective locations, except that windows rear of the driver's compartment, if tinted, shall have approximately 28 percent light transmission;
- C. Windshields shall comply with federal, Louisiana state and local regulations.

WINDSHIELD WASHERS

A windshield washer system shall be provided.

WINDSHIELD WIPERS

- A. A two-speed or variable speed windshield wiping system, with an intermittent feature, shall be provided and shall be operated by a single switch.
- B. The wipers shall meet the requirements of FMVSS No. 104, *Windshield Wiping and Washing Systems*.

SPECIALLY EQUIPPED SCHOOL BUS SPECIFICATIONS

INTRODUCTION

The specifications in this section are intended to supplement specifications in the BODY AND CHASSIS section. In general, specially equipped buses shall meet all the requirements of the preceding sections, plus those listed in this section. It is recognized that the field of special transportation is characterized by varied needs for individual cases and by rapidly emerging technologies for meeting individual student needs. Additional specifications may be required to fulfill applicable requirements of specific students' IEPs.

DEFINITION

A *specially equipped school bus* is any school bus that is designed, equipped and/or modified to accommodate students with special transportation needs.

GENERAL REQUIREMENTS

- A. Specially equipped school buses shall comply with the *National School Transportation Specifications and Procedures* and with the Federal Motor Vehicle Safety Standards (FMVSSs) applicable to their respective model year and with gross vehicle weight rating (GVWR) category.
- B. Specially equipped school buses shall comply with Louisiana specifications as enumerated in the Bus Body and Chassis Specifications section of this document.
- C. Any school bus to be used for the transportation of children who utilize a wheelchair or other mobile positioning device, or who require life-support equipment that prohibits use of the regular service entrance, shall be equipped with a power lift.

AISLES

All school buses equipped with a power lift shall provide a minimum 30-inch pathway leading from any wheelchair position to at least one 30 inches-wide emergency exit door. A wheelchair securement position shall never be located directly in front of (blocking) a power lift door location.

COMMUNICATION SYSTEM

- A. All school buses that transport individuals with disabilities shall be equipped with a two-way electronic voice communication system that can be used at any point on the vehicle's route.
- B. Each bus should have a public address system capable of driver communication with passengers inside and outside the bus.

FIRE SUPPRESSION SYSTEM (OPTIONAL)

- A. A fire suppression system is recommended for installation in the engine compartment.
- B. The chassis manufacturer may provide an automatic fire extinguisher system in the engine compartment.
- C. Fire suppression system nozzles shall be located in the engine compartment, under the bus, in the electrical panel or under the dash, but they shall not be located in the passenger compartment. The system must include a lamp or buzzer to alert the driver that the system has been activated.

GLAZING

Tinted glazing may be installed in all doors, windows and windshields consistent with federal, state (RS 32:361.1) and local regulations.

IDENTIFICATION

Specially equipped school buses shall display the International Symbol of Accessibility below the window line and/or on the metal portion of the rear emergency door. Such emblems shall be white on blue or black background, shall not exceed 12 inches square in size and shall be of a high-intensity retroreflective material meeting the requirements of Federal Highway Administration (FHWA) FP-85, *Standard Specifications for Construction of Roads and Bridges on Federal Highway Projects*.

PASSENGER CAPACITY RATING

In determining the passenger capacity of a school bus for purposes other than actual passenger load (e.g., vehicle classification or various billing/reimbursement models), any location in a school bus intended for securement of a wheelchair during vehicle operation shall be regarded as four (4) designated seating positions, and each lift area shall count as four (4) designated seating positions.

POWER LIFTS

- A. The power lift shall be located on the right side of the bus body.
- B. Vehicle lift and installation

General: Vehicle lifts and installations shall comply with the requirements set forth in FMVSS 403, Platform Lift Systems for Motor Vehicles, and FMVSS 404, *Platform Lift Installations in Motor Vehicles*.

1. Design loads: The design load of the lift shall be at least 800 pounds; however, lifts with a greater capacity are recommended to accommodate heavy motorized mobility devices. Working parts, such as cables, pulleys and shafts, which can be expected to wear, and upon which the lift depends for support of the load, shall have a safety factor of at least six (6), based on the ultimate strength of the material. Non-working parts, such as platform, frame and attachment hardware that would not be expected to wear, shall have a safety factor of at least three (3), based on the ultimate strength of the material.
2. Lift capacity: The lifting mechanism and platform shall be capable of operating effectively with a wheelchair and occupant mass of at least 800 pounds.
3. Controls: (See 49 CFR 571.403, S6.7, *Control systems*.)
4. Emergency operations: (See 49 CFR 571.403, S6.9, *Backup operation*.)
5. Power or equipment failures: (See 49 CFR 571.403, S6.2.2, *Maximum platform velocity*.) Platform barriers: (See 49 CFR 571.403, S6.4.7, *Wheelchair retention*.)
6. Platform surface: (See 49 CFR 571.403, S6.4.2, S6.4.3, *Platform requirements*.) (See also "Wheelchair or Mobility Aid Envelope" figure at the end of this subsection.)
7. Platform gaps and entrance ramps: (See 49 CFR 571.403, S6.4.4, *Gaps, transitions and openings*.)
8. Platform deflection: (See 49 CFR 571.403, S6.4.5, *Platform deflection*.)
9. Platform movement: (See 49 CFR 571.403, S6.2.3, *Maximum platform acceleration*.)
10. Boarding direction: The lift shall permit both inboard and outboard facing of wheelchair and mobility aid users.
11. Handrails: (See 49 CFR 571.403, S6.4.9, *Handrails*.)
12. Circuit breaker: A resettable circuit breaker shall be installed between the power source and the lift motor if electrical power is used. It shall be located as close to the power source as possible, but not within the passenger/driver compartment.
13. Excessive pressure: (See 49 CFR 571.403, S6.8, *Jacking prevention*.)
14. Documentation: The following information shall be provided with each vehicle equipped with a lift:

- a. A phone number where information can be obtained about installation, repair and parts. (Detailed written instructions and a parts list shall be available upon request.)
- b. Detailed instructions regarding use of the lift shall be readily visible when the lift door is open, including a diagram showing the proper placement and positioning of wheelchair/mobility aids on the lift.
- c. Training materials: The lift manufacturer shall make training materials available to ensure the proper use and maintenance of the lift. These may include instructional videos, classroom curriculum, system test results or other related materials.
- d. Identification and certification: Each lift shall be permanently and legibly marked or shall incorporate a non-removable label or tag that states that the lift conforms to all applicable (for the date of manufacture) requirements of the National School Transportation Specifications and Procedures. In addition, and upon request of the original titled purchaser, the lift manufacturer or an authorized representative shall provide a notarized Certificate of Conformance, either original or photocopied, which states that the lift system meets all the applicable requirements of the current National School Transportation Specifications and Procedures.

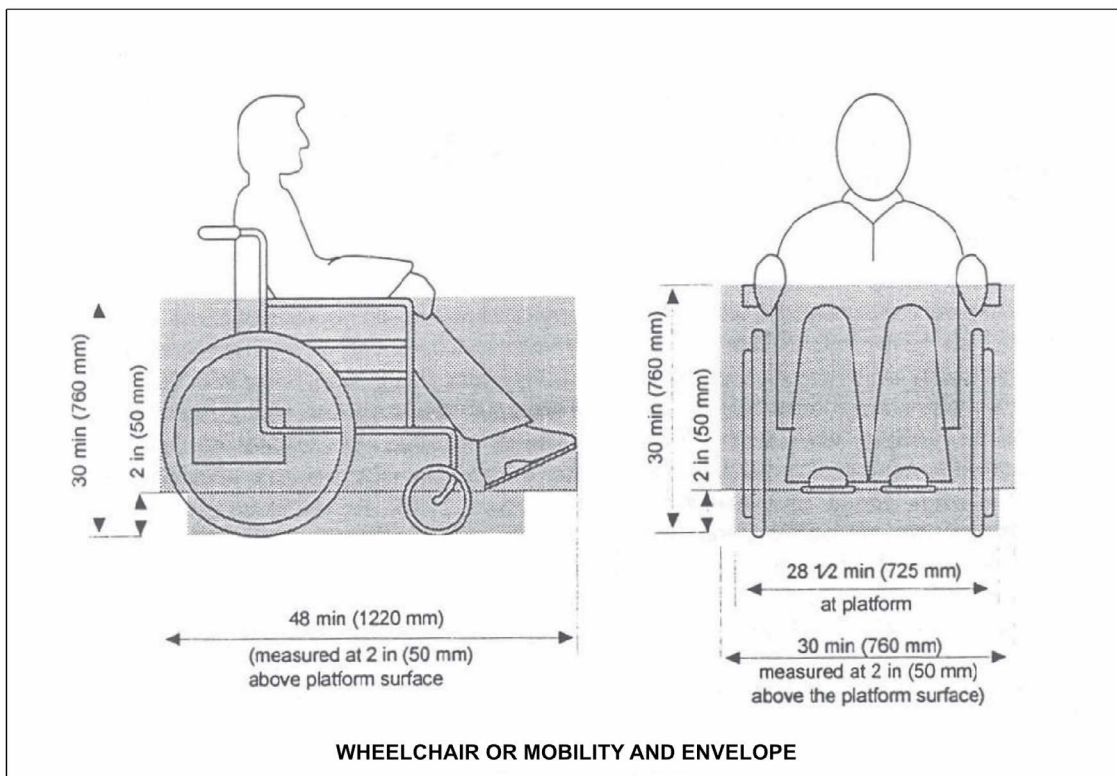

REGULAR SERVICE ENTRANCE

- A. On power lift-equipped vehicles, steps shall be the full width of the step well, excluding the thickness of the doors in the open position.
- B. In addition to the handrail required in the SCHOOL BUS BODY AND CHASSIS section, an additional handrail may be provided on all specially equipped school buses. This handrail shall be located on the opposite side of the entrance door from the handrail required in the SCHOOL BUS BODY AND CHASSIS section and shall meet the same requirements for handrails.

RESTRAINING DEVICES

- A. On power lift-equipped school buses with a GVWR of 10,000 pounds or more, seat frames may be equipped with attachment points to which belt assemblies can be attached for use with child safety restraint systems (CSRs) that comply with FMVSS No. 213, Child Restraint Systems. Any belt assembly anchorage shall comply with FMVSS No. 210, *Seat Belt Assembly Anchorages*.
- B. Alternatively, a child restraint anchorage system that complies with FMVSS No. 225, Child Restraint Anchorage Systems, may be installed.
- C. Seat belt assemblies, if installed, shall conform to FMVSS No. 209, Seat Belt Assemblies.
- D. Child safety restraint systems, which are used to facilitate the transportation of children who in other modes of transportation would be required to use a child, infant or booster seat, shall conform to FMVSS No. 213.

SEATING ARRANGEMENTS

Flexibility in seat spacing to accommodate special devices shall be permitted to meet passenger requirements. All seating shall meet the requirements of FMVSS No. 222, *School Bus Passenger Seating and Crash Protection*.

SECUREMENT AND RESTRAINT SYSTEM FOR WHEELCHAIRS AND WHEELCHAIR-SEATED OCCUPANTS

For purposes of understanding the various aspects and components of this section, the terms securement and tie down and the phrases securement system or tie down system are used exclusively in reference to the devices that anchor the wheelchair to the vehicle. The term restraint and the phrase restraint system are used exclusively in reference to the equipment that is intended to limit the movement of the wheelchair occupant in a crash or sudden maneuver. The term wheelchair tie down and occupant restraint system (WTORS) is used to refer to the total system that secures the wheelchair and restrains the wheelchair occupant.

- A. **WTORS** – general requirements:
 - 1. A wheelchair tie down and occupant restraint system installed in specially equipped school buses shall be designed, installed, and operated for use with forward-facing wheelchair-seated passengers and shall comply with all applicable requirements of FMVSS 222, *School Bus Passenger Seating and Crash Protection*, and SAE J2249, *Wheelchair Tie down and Occupant Restraint Systems for Use in Motor Vehicles*.
 - 2. The WTORS, including the anchorage track, floor plates, pockets or other anchorages, shall be provided by the same manufacturer or shall be certified to be compatible by manufacturers of all equipment/systems used.
 - 3. Wheelchair securement positions shall be located such that wheelchairs and their occupants do not block access to the lift door.
 - 4. A device for storage of the WTORS shall be provided. When the system is not in use, the storage device shall allow for clean storage of the system, shall keep the system securely contained within the passenger compartment, shall provide reasonable protection from vandalism and shall enable the system to be readily accessed for use.
 - 5. The WTORS, including the storage device, shall meet the flammability standards established in FMVSS No. 302, *Flammability of Interior Materials*.
 - 6. The following information shall be provided with each vehicle equipped with a securement and restraint system:
 - a. A phone number where information can be obtained about installation, repair and parts. (Detailed written instructions and a parts list shall be available upon request.)

- b. Detailed instructions regarding use, including a diagram showing the proper placement of the wheelchair/mobility aids and positioning of securement devices and occupant restraints, including correct belt angles.
- 7. The WTORS manufacturer shall make training materials available to ensure the proper use and maintenance of the WTORS. These may include instructional videos, classroom curriculum, system test results or other related materials.
- B. Wheelchair Securement/Tiedown: (See 49 CFR 571.222, S5.4.1, S5.4.2.) Each wheelchair position in a specially equipped school bus shall have a minimum clear floor area of 30 inches laterally by 48 inches longitudinally. Additional floor area may be required for some wheelchairs. Consultation between the user and the manufacturer is recommended to ensure that adequate area is provided.
- C. Occupant restraint system: (See 49 CFR 571.222, S5.4.3, S5.4.4.) If the upper torso belt anchorage is higher than 44 inches measured from the vehicle floor, an adjustment device, as part of the occupant restraint system, shall be supplied.

SPECIAL LIGHT

Doorways in which lifts are installed shall be equipped with a special light that provides a minimum of two foot-candles of illumination measured on the floor of the bus immediately adjacent to the lift during lift operation.

SPECIAL SERVICE ENTRANCE

- A. Power lift-equipped bodies shall have a special service entrance to accommodate the power lift.

Note: A special service entrance shall not be required if the lift is designed to operate within the regular service entrance, is capable of stowing such that the regular service entrance is not blocked in any way and a person entering or exiting the bus is not impeded in any way.

- B. The special service entrance and door shall be located on the right side of the bus and shall be designed so as not to obstruct the regular service entrance.

Note: A special service entrance and door may be located on the left side of the bus only if the bus is used only to deliver students to the left side of one-way streets and its use is limited to that function.

- C. The opening may extend below the floor through the bottom of the body skirt. If such an opening is used, reinforcements shall be installed at the front and rear of the floor opening to support the floor and give the same strength as other floor openings.
- D. A drip molding shall be installed above the special service entrance to effectively divert water from the entrance.
- E. Door posts and headers at the special service entrance shall be reinforced sufficiently to provide support and strength equivalent to the areas of the side of the bus not used for the special service entrance.

SPECIAL SERVICE ENTRANCE DOORS

- A. A single door or double doors may be used for the special service entrance.
- B. A single door shall be hinged to the forward side of the entrance unless this would obstruct the regular service entrance. If the door is hinged to the rearward side of the doorway, the door shall utilize a safety mechanism that will prevent the door from swinging open should the primary door latch fail. If double doors are used, the system shall be designed to prevent the door(s) from being blown open by the aerodynamic forces created by the forward motion of the bus, and/or shall incorporate a safety mechanism to provide secondary protection should the primary latching

mechanism(s) fail.

- C. All doors shall have positive fastening devices to hold doors in the “open” position when the special service entrance is in use.
- D. All doors shall be weather sealed.
- E. When manually operated dual doors are provided, the rear door shall have at least a one-point fastening device to the header. The forward-mounted door shall have at least three one-point fastening devices. One shall be to the header, one to the floor line of the body, and the other shall be into the rear door. The door and hinge mechanism shall have strength that is greater than, or equivalent to, the strength of the emergency exit door.
- F. Door materials, panels and structural components shall have strength equivalent to the conventional service and emergency doors. Color, rub rail extensions, lettering and other exterior features shall match adjacent sections of the body.
- G. Each door shall have windows set in a waterproof manner that are visually similar in size and location to adjacent non-door windows. Glazing shall be of the same type and tinting (if applicable) as standard fixed glass in other body locations.
- H. Door(s) shall be equipped with a device that will actuate an audible or visible signal located in the driver’s compartment when the door(s) is not securely closed and the ignition is in the “on” position.
- I. A switch shall be installed so that the lift mechanism will not operate when the lift platform door(s) is closed.
- J. Special service entrance doors shall be equipped with padding at the top edge of the door opening. The padding shall be at least three inches wide and one inch thick and shall extend the full width of the door opening.

SUPPORT EQUIPMENT AND ACCESSORIES

- A. In addition to the webbing cutter required in the BUS BODY AND CHASSIS section, each specially equipped school bus that is set up to accommodate wheelchairs or other assistive or restraint devices with webbing attached shall contain an additional webbing cutter properly secured in a location to be determined by the purchaser. The webbing cutter shall meet the requirements listed in the SCHOOL BUS BODY AND CHASSIS section, Seats and Restraining Barriers, paragraph E.
- B. Special equipment or supplies that are used in the bus for mobility assistance, health support or safety purposes shall meet local, federal and engineering standards that may apply, including requirements for proper identification. Equipment that may be used for these purposes includes, but is not limited to:
 - 1. Wheelchairs and other mobile seating devices. (See subsection on Securement and Restraint System for Wheelchairs and Wheelchair-seated Occupants.)
 - 2. Crutches, walkers, canes and other ambulating devices to assist ambulation.
 - 3. Medical support equipment. This may include respiratory devices, such as oxygen bottles (which should be no larger than 38 cubic feet for compressed gas) or ventilators. Tanks and valves should be located and positioned to protect them from direct sunlight, bus heater vents or other heat sources. Other equipment may include intravenous and fluid drainage apparatus.
- C. Each specially equipped school bus that is set up to accommodate wheelchairs or other assistive restraint devices should be equipped with an emergency evacuation device that is certified and tested to withstand at least a 300-pound load when used as an emergency stretcher or drag. This evacuation device shall be properly secured to the bus in a location to be determined by the purchaser.
- D. If transporting oxygen, refer to AMD Standard 003.

TECHNOLOGY AND EQUIPMENT, NEW

It is the intent of these specifications to accommodate new technologies and equipment that will better facilitate the transportation of students with special needs. New technology and equipment are acceptable for use in specially equipped vehicles if:

- A. Items do not compromise the effectiveness or integrity of any major safety system. (Examples of safety systems include, but are not limited to, compartmentalization, the eight-lamp warning system, emergency exits and the approved color scheme.)
- B. Items do not diminish the safety of the bus interior.
- C. Items do not create additional risk to students who are boarding or exiting the bus or are in or near the school bus loading zone.
- D. Items do not require undue additional activity and/or responsibility for the driver.
- E. Items generally increase efficiency and/or safety of the bus, generally provide for a safer or more pleasant experience for the occupants and pedestrians in the vicinity of the bus and/or generally assist the driver and make his/her many tasks easier to perform.

SCHOOL BUS INSPECTION PROGRAM

LOUISIANA SCHOOL BUS INSPECTION PROGRAM

The Louisiana Department of Education (Bulletin 119, §701) requires thorough semi-annual (or more frequent) inspections of school buses by inspectors who have been approved and authorized by the Louisiana Department of Public Safety and Corrections and by the driver who is preparing to drive (“pre-trip”), or who has just completed a trip (“post-trip”) in a school bus. Semi-annual inspections are more fully described in this section; pre-trip and post-trip inspections are described in Bulletin 119, Supplement II: *Louisiana Student Transportation Operational Procedures*.

School bus inspection programs vary among school districts, civil parishes and cities in Louisiana. The Louisiana Department of Public Safety approves inspection stations throughout Louisiana except for municipalities that have been authorized by the Louisiana Legislature to operate independently. School districts and private contractors can be authorized by the Department of Public Safety to inspect their respective bus fleets, provided they meet certain inspection criteria; otherwise, buses must be inspected by facilities and inspectors that are approved by the Department of Public Safety and Corrections for inspecting commercial motor vehicles.

INITIAL AND SEMI-ANNUAL SCHOOL BUS INSPECTIONS

- A. All school buses (i.e., route buses, spares and activity buses) shall be inspected initially within thirty (30) days of delivery and acceptance by the purchaser and shall be documented as complying with Louisiana school bus specifications and as “safe for transporting school students.”
- B. Additional inspections of all school buses shall be completed and documented not less than every six (6) months after the initial inspection described in paragraph A, above.
- C. Re-inspections or more frequent inspections may be ordered by the designated school bus inspector, the LEA representative or other authorized agent.
- D. All school buses shall be inspected by a Commercial Motor Vehicle Inspection Station that has been approved by the Louisiana Department of Public Safety.
- E. Inspectors shall ensure that all school buses comply with applicable FMVSSs, Louisiana statutory requirements and Louisiana Department of Education regulations and that each bus is certified as “safe for the transportation of passengers.”

INSPECTION PROCEDURE

Inspectors are provided CMV inspection handbooks that have been published by the Louisiana Department of Public Safety. Handbooks include items that must be inspected and applicable inspection procedures. Inspection tags (“stickers”) are placed inside the front windshield on the left side, out of the line of vision of the driver. Although inspections must be conducted every six months or more frequently, inspection tags may sometimes be affixed to the windshield only once during a twelve-month period. Alternative methods of documenting inspections are permitted to replace inspection tags that are mounted on the vehicle’s windshield.

OUT-OF-SERVICE CRITERIA

The purpose of criteria is to identify critical school bus components and provide tolerances that inspectors can utilize to determine if a school bus is safe for student transportation. While it is recognized that each state may enforce more stringent standards, this document includes criteria that are recommended by the National Congress on School Transportation in the publication *National School Transportation Specifications and Procedures* (2015 edition), which are intended to establish a baseline for inspecting and placing school buses out-of-service.

RESOURCE INFORMATION

49 CFR PARTS 570.1-570.63, *Vehicle in Use Inspection Standards*

49 CFR PARTS 400-599, *Federal Motor Vehicle Safety Standards*

49 CFR PARTS 393, 396, *Federal Motor Carrier Safety Regulations*

49 CFR APPENDIX G to Subchapter B, *Minimum Periodic Inspection Standards*

SCHOOL BUS RECOMMENDED OUT-OF-SERVICE CRITERIA

BACKING ALARM

Failure of the backing alarm to operate in compliance with Louisiana R.S. 32:378.D.

BODY EXTERIOR

- A. Any panel, rub rail or trim that is loose, torn, dislocated or protruding from the surface of the bus, creating a hazard (393.203); or
- B. Any engine, battery or other door that is not properly secured (393.203).

BODY INTERIOR

Aisle

- A. Aisle does not have the required clearance (571.217); or
- B. Obstructions in aisle that prevent passengers from egress to emergency exits (393.62) (393.203).

Door (Entrance)

- A. The student entrance door does not open or close properly;
- B. Door control handle does not lock in the closed position; or
- C. Door is equipped with a padlock or similar locking device (excludes interlock systems).

Floor

Floor not maintained to prevent slipping or tripping by passenger(s).

Handrail

- A. Handrail loose or missing; or
- B. Handrail fails the nut/drawstring test as defined by NHTSA and described in "Recommended Inspection Procedures," "School Bus Body Interior," "Nut and String Test," this document.

Panels

Any panel (e.g., ceiling, side or wheel well) protruding, having sharp edges or not secured so is likely to cause injury.

Seat (Driver)

- A. Driver seat is not securely fastened to vehicle and/or fails to maintain adjusted position (393.93); or
- B. Any part of the driver's safety restraint assembly is missing, not properly installed or defective as to prevent proper securement of occupant [393.93(a)(b)] (571.209).

Seat(s) and Barrier(s)

- A. Any seat or barrier that is not securely attached to the vehicle (393.91);
- B. Any seat or barrier material(s) that compromises the integrity of compartmentalization and occupant protection (571.222); or
- C. Seat spacing fails to comply with 571.222.

Stepwell

- A. Any part of the step well or support structure that is damaged; or
- B. Any part of the step well tread that is loose, torn or damaged that would present a tripping hazard.

BRAKE SYSTEM(S)

Adjustment

Any one brake beyond the adjustment limit (See Table 1: Brake Adjustment Specifications in Recommended School Bus Inspection Procedures section, this document.)

Air System

- A. Absence of effective braking action upon application of service brakes [393.48 (a)];
- B. Audible air leak at chamber (e.g., ruptured diaphragm, loose chamber clamp, etc.) [386.3(a)(1)];
- C. If an air leak is discovered and either the primary or secondary reservoir pressure is not maintained when these conditions exist [396.3(a)(1)]:
 - 1. Governor is cut-in;
 - 2. Reservoir pressure is between 80-90 psi;
 - 3. Engine is at idle; and
 - 4. Service brakes are either fully applied or released; or
- D. ABS malfunction indicator light not functioning as designed or illuminated on all ABS required vehicles.

Axle Brakes, General

- A. Chamber size mismatched on axle [393.47(b)];
- B. Mismatched brake chamber long stroke verses regular stroke [393.47(b)]; or
- C. Mismatched slack adjuster length [393.47(c)].

Brake Shoe/Pad/Lining

- A. Any lining thickness less than allowed by 393.47;
- B. Lining pad is cracked, broken, not firmly attached or missing (393.47) (*surface or heat cracks in the lining should not be considered out of service*);
- C. The friction surface of drum, rotor or friction material are contaminated by oil, grease or brake fluid (393.47);
- D. Loose or missing component (e.g., chambers, spiders, support brackets) (393.47);
- E. Fails to make contact with drum/rotor (e.g., frozen, binding, uneven) [393.48(a)];
- F. Absence of braking action on any axle (e.g., failing to move upon application of a wedge, S-cam, cam or disc brake);
- G. Rotor or drum has evidence of metal to metal contact on the friction surface [393.47(d)(1)]; or
- H. Brake pad, lining or shoe missing [393.47(a)].

Drums/Rotors

- A. External crack(s) that open upon application [393.47(a)]; or
- B. Any portion of the drum or rotor (discs) missing, broken, misplaced or cracked through rotor to center vent [393.47(a)].

Hoses and Tubing

- A. Brake hose with any damage extending through the outer reinforcement ply [393.45(a)];
- B. Audible leak at other than a proper fitting or connection [393.45(a)];
- C. Any bulge or swelling when brake are applied [393.45(a)];
- D. Any restriction due to cracked, broken or crimped line/hose [393.45(a)]; or
- E. Any line, tubing, hose or connection that is not constructed to meet standard (571.106).

Hydraulic Brake System

- A. System brake failure light or low fluid light on or inoperative (393.51);
- B. Reservoir is below minimum level [393.45(a)] (571.106);
- C. Any seeping, leaking or swelling of hose(s) under pressure [393.45(a)];
- D. Any leak in master cylinder unit [393.45(a)] (571.106).
- E. Any observable fluid leak in the brake system;
- F. Brake failure warning system is missing, inoperative, disconnected, defective, or activated while the engine is running with or without brake application [393.51(b)];
- G. ABS malfunction indicator light not functioning as designed or illuminated on all ABS required vehicles.

Parking Brake

- A. Fails to hold vehicle in stationary position on normal roadway conditions (absence of ice or snow) in forward or reverse (393.41) [571.105 S5.2.1 and S5.2.3(b)].
- B. Parking brake warning lamp fails to function as designed.

Pedal Reserve

No pedal reserve with engine running [393.40(b)].

Power Assist Unit

Fails to operate [396.3(a)(1)].

CROSSING CONTROL ARM (CROSSING GATE)

Failure of the crossing control arm to be properly installed and in complete working order, in compliance with Louisiana R.S. 17:164.1 and FMVSS 131.

DIFFERENTIAL

Cracked or leaking housing [393.207(a)].

DRIVESHAFT

- A. Driveshaft guard loose, missing, improper placement or bent (393.89); or
- B. Universal joint(s) worn or faulty, or obvious welded repair [393.209(2)(d)].

ELECTRICAL/BATTERY

Battery

- A. Battery not secured (393.30);
- B. Signs of leaking or excessive corrosion; or
- C. Battery lacks cranking capacity to start engine.

Cables

- A. Electrical cable insulation chafed, frayed, damaged or compromised insulation burnt, causing bare cable to be exposed [393.28, 396.3(a)(1)];
- B. Loose or corroded connections at battery posts or compromised insulation protection to electrical components [393.28, 393.77(b), 396.3(a)(1)]; or
- C. Missing or damaged protective grommets insulating main electrical cables through metal compartment panels (393.30).

Components

- A. Broken or unsecured mounting of electrical components [396.3(a)(1)]; or
- B. Electrical cable unsupported, hanging or missing clamps that may cause chafing or frayed conditions [393.28, 396.3(a)(1)].

Windshield Wipers

- A. Inoperative, missing or damaged wiper (393.78); or
- B. Wiper does not clean sweep area of driver's windshield (393.78).

EMERGENCY EQUIPMENT

- A. Fire extinguisher missing, not of proper type or size, not fully charged, has no pressure gauge, is not secured or is not readily accessible to the driver or passengers (393.95);
- B. Properly stocked and secured first aid kit and body fluid cleanup kit, webbing cutter (on Head Start and other buses equipped with occupant restraints); or
- C. Missing emergency triangles or unsecured triangle kit (571.125).

EMERGENCY EXITS

- A. Any emergency door, window or roof hatch that fails to open freely or completely as defined in 571.217;
- B. Door prop-rod device is missing or inoperative (571.217);
- C. Any emergency exit equipped with a padlock or similar locking device (excludes interlock systems);
- D. Any vehicle that lacks the required number of emergency exits (571.217);
- E. Any emergency exit not properly labeled and marked both inside and outside the vehicle as specified by 571.217;
- F. Any item blocking access to an emergency exit;
- G. Any item or modification that reduces the size of the opening and limits egress to the emergency exit by all passengers; or
- H. Emergency exit warning device is not audible in the driver seating position and in the vicinity of the emergency door or window (571.217).

ENGINE

- A. Any critical component that fails to function as designed (396.3); or
- B. Any fluid leak that would affect the safe operation of the vehicle (396.3).

EXHAUST SYSTEM

- A. The exhaust system is leaking or discharging directly below or at a point forward of the driver or passenger compartment [393.83(g)];

Note: Does not apply to proper venting for emission systems.

- B. No part of the exhaust system shall be located and likely to result in burning, charring or damaging the electrical wiring, the fuel supply or any combustible part of the vehicle [393.83(a)]; or
- C. The tail pipe not extending beyond the school bus body or extending more than two (2) inches beyond the rear bumper.

FUEL SYSTEM

CNG or LPG Fuels

- A. Any fuel leakage from the CNG Or LPG system detected audibly or by smell and verified by either a bubble test using non-ammonia, non-corrosive soap solution, or a flammable gas detection meter [396.3(a)(1)].

Note: Verification is needed to ensure that the sound is not either internal to the fuel system (such as gas flowing in a pressure regulator, or pressure equalizing between manifold tanks) or a leak in the air brake system.

- B. Any fuel leakage from the CNG or LPG system detected visibly (evidence such as ice buildup at fuel system connections and fittings) and verified by either a bubble test using non-ammonia, non-corrosive soap solution, or a flammable gas detection meter [396.3(a)(1)].

Note: Some brief fuel leakage or decompression may occur during refueling, causing temporary frosting of CNG or LPG fuel system parts. If the vehicle has been refueled shortly before inspection, care must be taken to distinguish these temporary frosting occurrences from actual leaks.

Liquid Fuels

- A. Any part of the fuel tank or fuel system not securely attached to the vehicle (393.65);
- B. A fuel system with a dripping leak at any point (393.67 Tank); or
- C. Dripping leak (396.3(a)(1) leak other than tank); or
- D. Missing fuel cap or system does not seal as designed.

LAMPS/SIGNALS

- A. Any one of the following lamps not working: brake, turn signal, tail, head (low beam), school bus overhead warning light (amber or red), hazard warning or stop arm lamp (571.108, 571.131);

Note: vehicle LED lamps must have more than 25% of the diodes unlit to be considered not working.

- B. Horn fails to function as designed (393.81);
- C. Backing lamp not working;
- D. Backing alarm not sounding when transmission is placed in reverse or forward gear or neutral, all when the vehicle is rolling backward;
- E. Any critical brake, telltale lamp, buzzer or gauge that fails to function as designed;

- F. Required stop arm(s) fail to operate with overhead red lights as mandated (571.131); or
- G. The crossing control arm fails to extend and retract as designed.

MIRRORS (571.111)

- A. Any mirror required to provide the driver with the entire field of view, missing, damaged, clouded or otherwise obscured so as to place children in a hazardous position;
- B. Any crossover mirror system or portion thereof that fails to hold a set adjustment;
- C. Any crossover mirrors directed to view any area other than for which they were intended; or
- D. Any part of the required field of vision obscured or not visible from the driver seated position.

STEERING SYSTEM

Ball/Socket Joints

- A. Any movement under steering load of a nut stud [396.3(a)(1)];
- B. Any motion, other than rotational, between any linkage member and its attachment point of more than $\frac{1}{8}$ inch measured with hand pressure only [393.209(d)]; or
- C. Any obvious welded repair [393.209(d)].

Front Axle Beam

Any crack(s) or obvious welded repair [396.3(a)(1)].

Nuts

Loose or missing fasteners on tie rod, pitman arm, drag link, steering arm or tie rod arm [396.3(a)(1)].

Pitman Arm

- A. Looseness of the pitman arm on the steering gear output shaft [393.209(d)]; or
- B. Any obvious welded repair [396.3(a)(1)] [393.209(d)].

Power Steering

- A. Auxiliary power assist cylinder loose [393.209(e)];
- B. Power steering system belts frayed, cracked or slipping [393.209(2)(e)]; or
- C. Power steering system leaking or insufficient fluid in reservoir [393.209(2)(e)].

Steering

- A. Any modification or condition that interferes with free movement of any steering component [393.209(d)]; or
- B. Steering travel restricted through the limit of travel in both directions [570.60(c)].

Steering Column/Wheel

- A. Absence or looseness of U-bolts or other positioning part(s) [393.209(c)];
- B. Welded or repaired universal joint(s) [393.209(d)];
- C. Steering wheel not properly secured [393.209(a)]; or
- D. Steering wheel lash/free play exceeds performance test (see Table #2) [393.209(b)].

Steering Gear Box

- A. Mounting bolt(s) loose or missing [393.209(d)];
- B. Crack(s) in gearbox or mounting brackets (393.209(d)) [396.3(a)(1)];
- C. Any obvious welded repair(s) [396.3(a)(1)] [393.209(d)]; or
- D. Looseness of yoke-coupling to the steering gear input shaft [393.209(d)].

Tie Rods/Drag Links

- A. Loose clamp(s) or clamp bolt(s) on tie rod or drag link(s) [396.3(a)(1)]; or
- B. Any looseness in any threaded joint [396.3(a)(1)].

SUSPENSION COMPONENTS

Air Suspension

- A. Deflated air suspension (one or more deflated air spring/bag) [393.207(f)]; or
- B. Air spring/bag is missing, broken, or detached at either the top or bottom (393.207(f)).

Axle Parts/Members

- A. Any U-bolt or other spring to axle clamp bolt(s) which are cracked, broken, loose or missing [393.207(a)];
- B. Any axle, axle housing, spring hanger(s), or other axle positioning parts which are cracked, broken, loose or missing that result in shifting of an axle from its normal position [393.207(a)];
- C. Any worn (beyond manufacturer specifications) or improperly assembled U-bolt, shock, kingpin, ball joint, strut, air bag or positioning component [570.61 (a)];
- D. Any spring hanger, assembly part or portion of leaf which is broken, separated or missing [393.207(c)]; or
- E. Any broken coil spring [393.207(d)].

Bumpers

- A. Front bumper is missing or not properly secured [393.203(e)]; or
- B. Rear bumper is missing or not properly secured (393.86).

Chassis/Frame/Unibody

- A. Any cracked, loose, sagging or broken, frame side rail. [393.201(a)];
- B. Any damage permitting the shifting of the body or imminent collapse of frame [393.201(a)];
- C. Any cracked, loose, broken frame member affecting support of functional components (e.g., steering gear, engine, transmission, body part or suspension) [393.201(a)];
- D. Any crack 1 ½ inch or longer in the frame side rail web which is directed toward bottom flange [393.201(a)]; or
- E. Any crack extending from the frame side rail web around the radius and into the bottom flange [393.201(a)].

Crossmembers

- A. Any cross member, outrigger or other structural support which is cracked, missing or deformed that affects the structural integrity of the vehicle (393.201);
- B. Three or more adjacent crossmembers broken or detached (393.201); or
- C. Any area of the floor that is sagging or soft due to broken crossmembers (393.201).

Outriggers/Body Supports

Any cross member, outrigger or other structural support which is cracked, missing, deformed or has rust holes where damage affects the safe operation of the vehicle.

TIRES/WHEELS/HUBS

Hub

- A. Excessive wheel bearing or kingpin play that exceeds ¼ inch (393.70) (570.61).
- B. Any bearing (hub) cap, plug, or filler plug that is missing or broken, allowing an open view into hub assembly [396.3(a)(1)];
- C. Smoking from wheel hub assembly due to bearing failure [396.3(a)(1)];
- D. When any wheel seal is leaking. This must include evidence of contamination of the brake friction material [396.5(b)];
- E. Note: Grease/oil on the brake lining edge, back of shoe, or drum edge and oil stain with no evidence of fresh oil leakage are not conditions for an out-of-service violation.
- F. Lubricant is leaking from the bearing hub and is accompanied by evidence that further leakage will occur [396.5(b)]; or
- G. No visible or measurable amount of lubricant showing in bearing hub [396.5(a)].

Tire Inflation

Tire is flat or has noticeable leak [393.75(a)(3)].

Tire Sidewall

- A. Any sidewall cut, worn or damaged to the extent that the steel or fabric cord is exposed [393.75(a)];
or
- B. Any observable bump, bulge or knot related to sidewall or tread separation [393.75(a)].

Tire Tread Depth

- A. Any front tire tread worn to less than 4/32 inch [393.75(b)]; or
- B. Any rear tire tread worn to less than 2/32 inch [393.75(c)].

Tire Type

- A. Any school bus operated with regrooved, recapped or retreaded tires on the front axle [393.75(d)];
or
- B. Any tire not of proper type (e.g., load range, size, mismatched on axle).

Wheels/Rims/Spiders

- A. Any nuts, bolts, studs, lugs or holes that are elongated, broken, missing, damaged or loose [393.205(b)];
- B. Any cracked or broken wheel or rim [393.205(a)]; or
- C. Any lock or slide ring broken, cracked, improperly seated, sprung or has mismatched rings [393.205(a)].

WHEELCHAIR LIFT-EQUIPPED VEHICLES

- A. Wheelchair lift does not function as designed or is inoperable;
- B. Missing manual pump handle;
- C. Platform lift manufactured after April 1, 2005 must meet all the following criteria, (as referenced in FMVSS 403 and 404):
 - 1. Jacking prevention;
 - 2. Manual backup operating mode;
 - 3. Interlocks to prevent forward or rearward mobility of the vehicle unless lift is stowed and lift doors are closed;
 - 4. Wheelchair retention device; and
 - 5. Platform outer barrier, inner roll stop and threshold warning device.
- D. Any hydraulic line leaking during lift operation;
- E. Wheelchair restraint system is missing, incomplete or improperly installed, loose, damaged or does not adhere to the securement manufacturer's recommendations; or
- F. Any required wheelchair occupant restraint system not in compliance (571.222).

WINDOWS

- A. Any glass or glazing that is broken through or missing (393.60);
- B. Any glass not of approved type [393.60(a)];
- C. Windshield has discoloration or other damage in that portion extending upward from the height of the topmost portion of the steering wheel, but not including a two-inch border at the top and a one-inch border at each side of the windshield or each panel thereof, except as follows:
 - 1. Color or tint applied by the manufacturer for the reduction of glare;
 - 2. Tinting that does not comply with Louisiana RS 32:361.1;
 - 3. Any crack not over $\frac{1}{4}$ inch long, if not intersected by any other crack;
 - 4. Any damaged area, that can be covered by a disc $\frac{3}{4}$ inch in diameter, if not closer than three inches to any other such damaged area; or
 - 5. Driver's side area window(s) have chips, clouding, or cracks that obscure the driver's vision [393.60(c)]; or
- D. No operable defrosting and defogging system to clear the driver's windshield (571.103).

RECOMMENDED SCHOOL BUS INSPECTION PROCEDURES

WARNING! Please **READ and follow** these instructions to avoid personal injury or death. Prior to performing any inspection procedures, always ensure that the vehicle is properly secured, wheels chocked, and that the ignition key is controlled. Proper safety equipment should always be used.

When working on or around a vehicle, the following general precautions should be observed at all times:

- A. Park the vehicle on a level surface, apply the parking brakes and always block the wheels.
- B. Always wear safety glasses and other appropriate safety gear.
- C. Stop the engine and remove ignition key when working under or around the vehicle.
- D. When working in the engine compartment, the engine should be shut off and the ignition key should be removed. Where circumstances require that the engine be in operation, **EXTREME CAUTION** should be used to prevent personal injury resulting from contact with moving, rotating, leaking, heated or electrically charged components.

BACKING ALARM

With engine running, place transmission in reverse, release the parking brake and accelerate. Alarm should be sounding. With bus rolling backward, shift into neutral. If the backing alarm stops operating, the alarm does not meet Louisiana specifications (R.S. 32:378), and should be “out of service” until the alarm is replaced.

BODY EXTERIOR

Visually inspect the body exterior to ensure that there is not any panel, rub rail or trim that is loose, torn, dislocated or protruding from the surface of the bus that would create a hazard.

All engine, battery or other doors must be securely mounted and properly installed.

BODY INTERIOR

Aisle

- A. Visually inspect the aisle to ensure that all aisles, including aisle (or passageway between seats) leading to emergency door are a minimum of 12 inches.
- B. Visually inspect to ensure that there are no obstructions in an aisle that would prevent passengers from egress to emergency exits.
- C. On school buses with a side emergency door, check that aisle space from center aisle to side of emergency door is 12 inches by measuring between the vertical line of the seat back and the face of the next seat cushion or bottom of a flip seat.
- D. On buses equipped with flip up seats, inspect to ensure the seat cushion rises to a vertical position automatically when not occupied.

Door, Entrance

Visually inspect and operate entrance door and inspect door to properly open and close without any obstruction of movement. Inspect manually operated door to make sure door will maintain an open and closed position. Door shall not have any locking device except for interlock systems. On power-operated entrance doors, the emergency release valve, switch or device to release the entrance door must be placed above or to the immediate left or immediate right of the entrance door and must be clearly labeled.

Floor

Visually inspect floor covering, aisle and cove molding strips for condition and adhesion. Check fastening holes for cracks, and check condition of rubber in aisle to ensure that there are no unsealed holes or cracks through the underside of the bus and that there is no damage to the coverings which could cause a trip or slip hazard.

Handrail

Handrail must be securely mounted and all OEM hardware present. Perform the NHTSA *Nut and String Test* as described and illustrated below.

Nut and String Test

The Handrail Inspection Tool and Procedure

The inspection tool is inexpensive and the procedure for detecting potentially fatal handrail designs is quite simple. The inspection tool is a standard $\frac{1}{2}$ inch hex nut measuring $\frac{3}{4}$ inch across the flats. This nut is tied to $\frac{1}{8}$ inch thick cotton cord measuring 36 inches in length with overhand knots. The drawstring should have a minimum length of 30 inches, when tied to the nut and attached so that a pull of at least 10 pounds does not separate the nut from or break the drawstring.

Steps to conduct a handrail inspection are:

- Stand on the ground outside of the bus;
- Drop the inspection tool between the handrail and step well wall, simulating the typical way students exit the bus;
- Draw the inspection tool through the handrail in a smooth, continuous slow motion; and
- Repeat this procedure several times (minimum of three times).



Note: It is important to drop the inspection tool over the handrail in such a way as to simulate a child exiting the bus. This is a drop-and-drag test. Do not create a snagging situation by placing the nut in an area that would not be exposed to a drawstring or other articles.

Inspection Results

Take the bus out of service and repair it if the inspection tool catches or snags anywhere on the handrail. If the nut separates from the drawstring or the drawstring breaks, reassemble the tool and retest. If the inspection tool pulls freely without catching or snagging, the bus should not be rejected.

Panels

Visually inspect all interior sidewall, rear, ceiling and driver's area paneling for secure fastening, projections or sharp edges and general condition.

Seat(s) and Barrier(s)

- A. Visually inspect all seats and barriers to ensure that all are securely mounted and are not loose or broken.
- B. All seats shall be forward-facing and securely fastened to the bus body. Passenger seat cushions shall be fastened to prevent the cushions from disengaging from the seat frames in the event of an accident. There shall be a minimum space of 24 inches between the forward surface of a seat back and the rear surface of the seat or barrier ahead measured across the seat cushion without depressing any surface. The forward surface may have side bolsters that briefly reduce the width to

less than 24 inches provided the remainder of the seat measures at least 24 inches.

- C. Seats and barriers should appear symmetrical. Seats/barriers that do not appear symmetrical should be physically inspected to ensure seat covering and/or padding is not significantly compromised and complies with FMVSS 571.222.

Seat, Driver

- A. Visually inspect driver's seat to ensure that it is securely fastened to the vehicle.
- B. Visually inspect the driver's seat for its ability to maintain the adjusted position. Inspect driver's restraining device (seat belt) for fraying, attaching hardware and the capacity of the seat belt for maintaining the driver in the seated position.

Stepwell

Visually inspect the stepwell for the condition of support structure to ensure structural stability. Inspect stepwell treads to ensure proper securing and adhesion to stepwell. Visually inspect step treads for any excessively worn areas that may pose a tripping or slip hazard.

BRAKE SYSTEMS

Air System

- A. With full system air pressure, depress the brake pedal and inspect each wheel end brake to determine if effective braking forces are applied to each wheel end brake. There should be no audible air loss at supply lines, fittings, valves or brake chambers.
- B. With full system pressure, make a single full service brake application with the parking brake and ignition off. Note the gauges and listen for air leaks. Release the service brake.
- C. If an air leak is detected at any point in the inspection process, the inspector should check the vehicle's air loss rate following these procedures:
 - 1. Set engine at idle and release brakes;
 - 2. Reduce air pressure in reservoir to 80 psi;
 - 3. Make a full brake application with governor cut-in; and
 - 4. Check air pressure gauge after initial application for air loss. Air pressure should be maintained or increase. A drop in pressure indicates a serious air leak in the brake system.

Air Brakes Measurement

The following procedure is based on the applied stroke method for measuring the movement of the brake chamber push rod:

- A. Release the spring brakes and visually check each brake to ensure that it is in the normal released position.
- B. With the brakes released, make a mark where the pushrod exits the brake chamber.
- C. With the engine off, make a series of brake applications to reduce the reservoir pressure to between 90 to 100 psi.
- D. Apply and hold a full brake application (90 to 100 psi).
- E. Measure the distance between the mark and the face of the brake chamber. The difference between measurements is called the chamber applied stroke.

Note: Any brake that is beyond the re-adjustment limit will require repairs and/or adjustment. (See Table 1: *Brake Adjustment Specifications* below.)

Table 1: Brake Adjustment Specifications

Brake adjustment: Shall be less than those specifications contained herein relating to “Brake Adjustment Limit.” (Dimensions are in inches.)

Clamp Type Chamber Data		
Type	Outside Diameter	Brake Adjustment Limit
6	4 ¹ / ₂	1.25
9	5 ¹ / ₄	1.375
12	5 ¹¹ / ₁₆	1.375
16	6 ³ / ₈	1.75
20	6 ²⁵ / ₃₂	1.75
24	7 ⁷ / ₃₂	1.75
30	8 ³ / ₃₂	2
36	9	2.25

“Long Stroke” Clamp Type Brake Chamber Data		
Type	Outside Diameter	Brake Adjustment Limit
12	5 ¹¹ / ₁₆	1.75
16	6 ³ / ₈	2.0
20 (2 ½” Rated Stroke)	6 ²⁵ / ₃₂	2.0
20 (3” Rated Stroke)	6 ²⁵ / ₃₂	2.5
24 (2 ½” Rated Stroke)	7 ⁷ / ₃₂	2.0
24 (3” Rated Stroke)	7 ⁷ / ₃₂	2.5
30	8 ³ / ₃₂	2.5

DD-3 Brake Chamber Data		
Type	Outside Diameter	Brake Adjustment Limit
30	8 ¹ / ₈	2.25

Note: This chamber has three air lines and found on motorcoaches.

Wedge Brake Data
The combined movement of both brake shoe lining scribe marks shall not exceed 1/8 inch (3.18mm).

Brake Shoe/Pad/Lining

- A. Visually inspect all brake linings/shoes/pads. Linings may be checked through inspection slots. All shoes/pads/linings shall comply with the applicable standards.
- B. The brake lining/pad thickness shall not be less than $\frac{3}{16}$ inch at the shoe center for a shoe with a continuous strip of lining, less than $\frac{1}{4}$ inch at the shoe center for a shoe with two pads, or worn to the wear indicator if the lining is so marked, for air drum brakes.
- C. The brake lining/pad thickness shall not be less than $\frac{1}{16}$ inch for air disc brakes, or $\frac{1}{16}$ inch or less for hydraulic disc brakes.
- D. Visually inspect the brake lining/pad to ensure that it is firmly attached to the shoe, is not cracked or broken, and that the friction surface is not saturated with oil, grease, or brake fluid.
- E. Visually inspect all brake components mounting hardware for any loose, cracked, broken or missing items. This inspection should be performed with the brakes released and with the brakes applied. It may be necessary to remove inspection access covers, brake dust covers or, in some instances, pull wheels and drums to accomplish the inspection.

Chamber Size

Visually inspect all brake chambers to ensure they are properly marked, in good operating condition, have no visible damage, and are properly matched. Chambers must be matched by size, type and stroke.

Drums/Rotors

- A. Visually inspect all brake drums/rotors for any external cracks that open when brakes are applied. (Do not confuse short hairline internal check cracks with flexural cracks.)
- B. Inspect for any portion of the drum/rotor missing or in danger of falling away.

Note: It may be necessary to remove inspection access covers, brake dust covers or, in some instances, pull wheels and drums to accomplish the inspection.

Hoses and Tubing

- A. Carefully perform a visual inspection of all system hoses, lines, and tubing.
- B. Inspect all hoses, lines, and tubing for any audible leak (if air), or visible leak (if hydraulic), any bulging/swelling when the system is pressurized, any hose, line, or tubing is cracked, broken or crimped in such a manner as to restrict flow, any hose abraded (chafed) through outer cover to fabric layer or any line/tubing, and for proper securement and support.

Hydraulic Brakes Measurement

- A. With the brake pedal in the full upright position, the inspector shall measure the distance between the brake pedal and the floor or firewall. With the engine running, a single firm brake application shall be made and the distance between the brake pedal and the floor or firewall shall be measured a second time. The difference shall be recorded.
- B. With vehicle stopped and engine running, depress brake pedal. The system must be able to maintain brake pedal height under moderate foot force (40-60 pounds) for one minute without pumping. With vehicle in stopped position and brake pedal depressed under moderate foot force (40-60 pounds) there should be a minimum of $\frac{1}{3}$ of the total available pedal travel (manufacturer's specification) remaining on non-powered systems.

Hydraulic Brake System

- A. With the engine off, turn the ignition switch to the "on" position and check the instrument panel for visible and audible warning signals to indicate system malfunction. If bus is equipped with vacuum assist, it shall have a visible warning signal and gauge to indicate any loss of vacuum. Audible signals must be loud enough to be heard over engine noise.

- B. Visually inspect the master cylinder to determine if it is below the minimum fill requirements, is leaking, is loose or improperly mounted.
- C. Visually inspect the hydraulic fluid reservoir level in the master cylinder unit. Inspect for any fluid leaks on wheel cylinders/calipers, master cylinders, hose connection and hydrovac and on buses using vacuum-assisted brakes. Check for brake fluid around the brake booster between the booster and firewall.

Parking Brake

- A. With the engine operating and the park brakes set, place the transmission in both forward and reverse gears to determine if brakes will hold vehicle stationary.
- B. Visually and physically check condition of parking brake system and parking brake warning light.

Pedal Reserve

- A. With the brake pedal in the full upright position, the inspector shall measure the distance between the brake pedal and the floor or firewall. With the engine running, a single firm brake application shall be made and the distance between the brake pedal and the floor or firewall shall be measured a second time. The difference shall be recorded.
- B. With vehicle stopped and engine running, depress brake pedal. The system must be able to maintain brake pedal height under moderate foot force (40-60 pounds) for one minute without pumping. With vehicle in stopped position and brake pedal depressed under moderate foot force (40-60 pounds) there should be a minimum of $\frac{1}{3}$ of the total available pedal travel (manufacturer's specification) remaining on non-powered systems.

Power Assist Unit

- A. Electric/Hydraulic Assist: With engine off, depress the brake pedal. The electric/hydraulic brake assist motor must operate.
- B. Hydrovac Assist: With engine off, the driver shall pump the brakes to exhaust all reserve. Hold firm pressure on the brake pedal and start the engine. The pedal should fall slightly. Failure of the pedal to fall slightly indicates a malfunction of the power-assist unit.
- C. Hydro-boost: After 2-3 brake applications with the engine off, start the vehicle while maintaining pressure on the brake pedal. The pedal should push briefly, and then fall as the power assist engages.

Slack Adjuster Length

Measure from the center of the S-cam to the center of the push rod clevis pin. All slack adjusters on a single axle shall be of the same type and length.

DIFFERENTIAL

The Inspector shall visually inspect the differential and differential housing for cracks and leaks. Careful attention shall be made to the areas of mounting attaching hardware and wheel end areas. Housing vent shall be inspected to ensure that it is not clogged and is functional by twisting the vent cap by hand.

DRIVESHAFT

- A. Visually and physically inspect each segment of the driveshaft and associated hardware. Inspect for bends, cracks, missing weights or debris entangled in the shaft. Each shaft more than 18 inches long shall be equipped with a suitable guard to prevent an accident or injury in the event of its fracture or disconnection. The inspector shall check to ensure that the driveshaft guards are not loose, bent or missing.

- B. Visually and physically inspect each universal joint center bearing(s) shall not be loose or worn and shall have all attaching hardware securely fastened. The inspector shall check for lateral and vertical movement of the universal joints and center bearing by grasping the universal joint and attempting to move the joint laterally and vertically. Inspector shall inspect universal joints for substandard or welded repairs.
- C. Visually inspect driveshaft for proper phasing. (See illustration.)

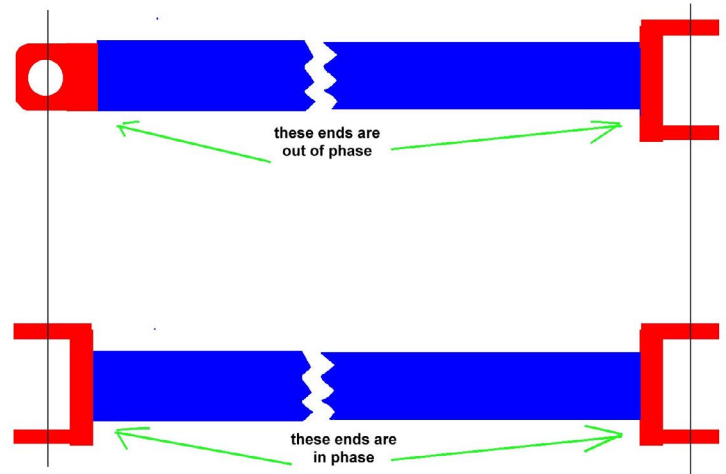

ELECTRICAL/BATTERY

Battery

- A. Visually and physically inspect that the battery(ies) is(are) securely mounted and no signs of leaking, or excessive corrosion.
- B. Crank engine to ensure adequate battery capacity to start engine.

Cables

- A. Visually inspect all electrical cabling and wiring for chafed, frayed, damaged or burnt insulation.
- B. Visually and physically inspect for corroded or loose connections at the battery terminals. Inspect for unsuitable insulation to electrical cabling.
- C. Inspect for missing or damaged protective grommets insulating all electrical cables through metal compartment panels. All electrical cabling passing through a metal surface shall pass through an insulated grommet as to provide adequate protection against chafing and shorting.
- D. Visually and physically inspect for any broken or unsecured mounting of electrical components.
- E. Visually and physically inspect electrical cabling for securement, routing or any unsecured wiring that may cause chafing or frayed conditions.

Windshield Wipers

Operate wiper and washer system. The wiping system should be power-driven with at least two speeds and should be able to clean the area of the windshield within the wiping pattern. Wipers should operate with a minimum of 45 cycles per minute.

EMERGENCY EQUIPMENT

- A. Visually inspect that the fire extinguisher is readily accessible to the driver and passengers, that it is fully charged of proper type and size, is properly secured and has a working pressure gauge.
- B. Visually inspect any other emergency equipment (first aid kit, body fluid kit, webbing cutters and emergency reflective triangles) and ensure that these items are fully stocked (see Specifications section), functional and properly secured.

EMERGENCY EXITS

- A. Visually inspect all emergency exits.
 1. Operate all emergency exits. Exits must open freely and completely.
 2. Door prop rods must operate freely and hold door or exit in open position without obstructing exit.

3. There shall be no padlocks or any other locking devices on exits except interlocking systems.
- B. Visually inspect all exits to ensure they are clearly labeled and marked on both the inside and outside of the bus.
- C. Ensure that all exits have an audible device to alert the driver of an open exit door or window.

Note: FMVSS 571.217 defines the number of exits for each type of bus.

ENGINE

- A. Visually inspect engine and surrounding components for evidence of fluid leaks and loose or damaged components. Inspector shall start engine. While engine is operating, inspector shall visually and audibly monitor engine for proper operation, leaks and unusual noises of engine or components.
- B. Inspect cooling fan per manufacturer's recommendations.
- C. Visually and physically inspect all drive belts for proper alignment and tension per manufacturer's recommendations. All belts shall be free of cracking, frays, fluid, glazing and excessive wear. Inspect belt-tensioner per manufacturer's recommendations.
- D. Visually inspect all hydraulic, coolant, fuel and pneumatic hoses for damage, proper routing, proper type and proper securement. Hoses shall be routed in such a way as to avoid contact with exhaust, rotating or moving engine components or sharp edges. Hoses shall not be cracked, leaking, swollen or chaffed.

EXHAUST SYSTEM

- A. Visually and audibly inspect the complete exhaust system including muffler, diesel particulate filter (DPF) and diesel oxidation catalyst (DOC) for leaks, restrictions and damage and to ensure that exhaust is not discharging directly below the driver or passenger compartment. All exhaust emission control devices shall be installed and operating per the manufacturer's recommendations.
- B. Inspect for the presence and condition of heat shielding over and around all piping, and components where specified by vehicle manufacturer.
- C. Visually and physically inspect all exhaust system mounting hardware for loose, missing or damaged components and that it is securely attached. Inspect to ensure that all clamps are in place and secure.
- D. Visually inspect exhaust system for indications of, and areas likely to result in, burning, charring or damaging the electrical wiring, the fuel supply or any combustible part of the vehicle.
- E. Visually check the tailpipe to ensure that if it extends to the rear of the bus, it extends beyond the rear of the bus body but not more than two inches beyond the rear bumper.

FUEL SYSTEM

- A. Visually inspect all parts of the fuel tank, fuel tank cage and fuel system to include lines, hoses, filters, fill cap and fittings for indications of damage or leaks.
- B. Visually and physically inspect fuel lines and hoses for proper securement, routing and missing or loose clamps that may cause chafing or come in contact with electrical components.

LAMPS/SIGNALS

- A. Visually inspect all lamps, such as brakes, turn signals, tail, head (low beam), overhead warning lights (amber and red), hazard warning and stop arm lights to ensure proper visibility and operation. Turn signals should flash at a rate of 60 to 120 times per minute.
- B. Inspect that the horn functions and is audible from approximately 200 feet away.

- C. Inspect the crossing control device, if equipped, for proper operation (e.g., that it extends and retracts as designed).

MIRRORS

Visually inspect all mirrors to identify any mirror that is damaged, clouded or otherwise has an obscured area. All mirrors should hold a set adjustment. All mirrors should be directed to view the intended area for which they are designed.

STEERING SYSTEM

Ball and Socket Joints

- A. With the bus on the ground, the inspector shall examine the ball joint nut stud for movement while the steering wheel is being rocked in a back-and-forth action. The inspector shall examine the ball/socket joint for weld repairs.
- B. Check for lateral and vertical movement by grasping the tie rod and drag link sockets attempting to laterally and vertically move the ball joint. (Rotational movement will not be considered.) Any motion other than rotational, greater than 1/8 inch that can be detected by movement with two hands with moderate strength in any connecting joint is a defect.

Front Axle Beam

Visually examine the front axle beam for any obvious bend or twist, any cracks, or any welded repair.

Hoses/Fluids

Visually examine the power steering fluid reservoir for proper fluid level. With the system operating, inspect all system components, hoses and fittings for leaks.

Nuts

Visually examine all tie rods, pitman arm, drag link, steering arm and tie rod arm for looseness and missing fasteners.

Pitman Arm

- A. While the steering wheel is being rotated in a back-and-forth motion; visually inspect the pitman arm and output shaft connection for looseness at the output shaft joint.
- B. The pitman arm shall also be inspected for damage, cracks or welded repairs.

Power Steering

- A. The inspector shall manually manipulate the auxiliary power assist cylinder to check for looseness. The inspector shall start the bus and rotate the steering wheel in a back-and-forth action to ensure the power steering pump is operable.
- B. With the engine stopped inspect the system drive belt(s) for any fraying, cracks or fluid saturation. Check belt tension. On units equipped with automatic tensioner ensure that tensioner moves freely.
- C. Inspect the fluid reservoir while at operating temperature to ensure that the fluid level is not below add mark. Inspect for signs of fluid leakage.

Steering

- A. Visually inspect for any modification or other condition that interferes with free movement of any steering component. Turn steering wheel through a full right and left turn and feel for binding or jamming conditions. Both front wheels must be capable of being turned to full right or full left without binding or interference.

- B. Inspect turn stops by observing for shiny spots and/or signs of wear due to contact with other vehicle components on the sides of tires, drag links, pitman arm, shock absorbers or brake lines.

Steering Column/Wheel

- A. Inspect steering column for any looseness in bolts, clamps, positioning parts or universal joints. Inspect flexible coupling in steering column (if the vehicle is so equipped) for excessive misalignment and tightness of clamp bolt or nut.
- B. The steering column and components shall also be inspected for damage, cracks or welded repairs. Inspect steering wheel to ensure that it is properly positioned and secured.
- C. Place steering axle wheels in a straight ahead position have an assistant turn the steering wheel until movement is observed at the left road wheel and measure the steering wheel movement from starting position to wheel movement position. Compare this measurement to the applicable listing in Table 2: Steering Wheel Free Play, below.

Table 2: Steering Wheel Free Play

Steering Wheel Free Play: Steering wheel free play shall not exceed the requirements listed in the following chart:

Steering Wheel Diameter	Manual System Movement 30	Power System Movement 45
16" (41cm)	2" (5.1cm)	4 1/2" (11.5cm)
18" (46cm)	2 1/4" (5.4cm)	4 3/4" (12cm)
20" (51cm)	2 1/2" (6.4cm)	5 1/4" (13.5cm)
22" (56cm)	2 3/4" (7cm)	5 3/4" (14.5cm)

Steering Gear Box

- A. Visually examine the steering gear box for any loose, damaged or missing mounting bolts. Inspect for cracks in the gear box, mounting brackets or any obvious welded repairs.
- B. While having an assistant rock the steering wheel back-and-forth; visually inspect the steering shaft and gear box for any looseness where the steering gear box is mounted to the frame. Visually inspect steering shaft coupler for cracks, damage or looseness.
- C. With the engine operating inspect for excessive fluid and/or oil leak (observable movement of fluid).

Tie Rods/ Drag Links

- A. While having an assistant to rock the steering wheel back-and-forth, visually inspect the tie rod ends, crossbar, and drag links for any looseness at the steering linkage pivot points.
- B. Check for lateral and vertical movement by grasping the tie rod and drag link sockets attempting to laterally and vertically move the ball joint (rotational movement will not be considered). Any motion, other than rotational, greater than 1/8 inch that can be detected by movement with two hands with moderate strength in any connecting joint is a defect.
- C. Check crossbar for structural damage and crossbar clamps for secure mounting.

SUSPENSION COMPONENTS

Axle Parts/Members

- A. Visually and physically inspect all front and rear axle components. Inspect all U-bolts and other suspension to axle mounting hardware for cracks, breaks, looseness or improper type.
- B. Inspect axle, axle housing, spring hanger(s), shackles or other axle components for alignment, cracks, breaks and loose or missing items that could result in shifting of an axle from its normal position.
- C. Inspect front axle beam for signs of improper repair (e.g., welding or heating).
- D. Inspect for any worn (beyond manufacturer specifications) or improperly assembled U-bolt, shock, kingpin, ball joint, strut, air spring or positioning components.
- E. Inspect all leaf spring hangers, hanger assemblies or portions of leaf for broken, separated, sagging, bent, abnormally worn (beyond manufacturer specifications), shifted or missing components.
- F. Inspect pins and bushings for wear, off-center spring eye, rubbing shackle or non-symmetric joints. Inspect for any broken, weak or damaged coil spring and mounting assemblies.
- G. Visually and physically inspect all hydraulic shock absorbers for leaks, looseness, damage or missing components.
- H. Inspect air suspension (if equipped). Observe that the vehicle is lifting level. With the air system fully charged, inspect for any audible or visual air leakage at the air spring assembly, supply hoses and connections.

Caution: Inspector should use caution whenever underneath the vehicle. There may not be sufficient room underneath the vehicle should a problem occur with the air suspension system.

Bumpers

Visually inspect front and rear bumpers for missing attaching hardware or broken hardware. Ensure bumpers are properly mounted and secure and that there is no point protruding beyond the confines of the vehicle so as to create a hazard.

Chassis/Frame/Unibody

- A. Visually inspect frame for cracks, loose attaching hardware, sagging, broken, or unapproved welds to frame side rail or flange.
- B. Visually and physically inspect for body hold-down components for damage that would permit the shifting of the body.
- C. Inspect for cracked, loose, bent, broken or unapproved welds to frame member that affect support of functional components (e.g., steering gear, engine, transmission, body parts or suspension). Welding to frame should be performed only by manufacturer or designee.

Note: Inspect for any crack 1 ½ inch or longer in the frame side rail web which is directed toward bottom flange or any crack extending from the frame side rail web around the radius and into the bottom flange.

Crossmembers

- A. Visually and physically inspect all crossmembers, attaching hardware and other structural supports for cracks or deformations. Visually inspect for three or more adjacent cross members that are missing, broken, damaged or loose.
- B. Inspect any area of the floor that is sagging, weak or damaged due to broken, damaged or loose crossmembers.

Outriggers/Body Supports

Visually inspect all outriggers and attaching hardware for cracks, missing bolts and damage.

TIRES/WHEELS/HUBS

Hub & Assemblies

- A. Visually inspect kingpin and wheel bearing assemblies for looseness, damage, missing or loose fasteners. This shall include locking pins, draw keys, caps and bearings.
- B. Physically inspect kingpin and bearing assemblies for play as follows: with the tire raised off the ground, grasp tire at top and attempt to move the wheel assembly in and out. If movement is present, inspector can help to identify the source by following this procedure:
- C. Have an assistant fully apply brakes while rechecking play. If movement disappears with brakes applied, then play is in the wheel bearings. If movement remains, it is most likely in the kingpin area. Assembly shall not have excessive kingpin play that exceeds .250 inch measured at outside edge of tire or wheel bearing movement that exceeds .010 inch measured at bearing hub.
- D. Visually inspect A-frames and bushings on Type A vehicles. Inspect bushings for wear, cracking, splitting, or severe extrusion from suspension parts.
- E. For vehicles equipped with “wet hubs” or oil bath hubs the inspector should visually check the site glass for lubricant level.

Tire Inflation

- A. Visually inspect that tires are properly inflated and do not have noticeable leaks. (See 393.76 (h) (1),(2).) If pressure is questionable, inspector shall use a tire pressure gauge to verify pressure.
- B. Visually inspect valve stem for damage and presence of valve cap.

Tire Sidewall

Inspector shall inspect tire sidewall for cuts, wear and any observable bumps or bulges.

Tire Tread Depth

- A. Visually inspect for any front tire worn to less than $\frac{1}{32}$ inch.
- B. Visually inspect for any rear tire worn to less than $\frac{2}{32}$ inch.
- C. If a visual inspection cannot determine that the tire meets the minimum depth requirement, the inspector shall use a commercial tire depth gauge to verify tread depth.

Tire Type

- Visually inspect the steer axle (front) to ensure that no recapped, re-grooved tires are present.
- Visually inspect tires for improper wear patterns. (See Tire Wear Chart below.)
- Check proper type (i.e., load range, size, mismatched on axle).

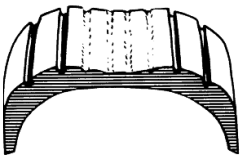
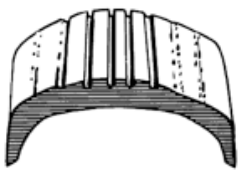
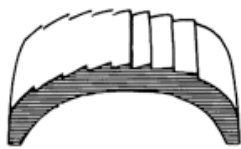
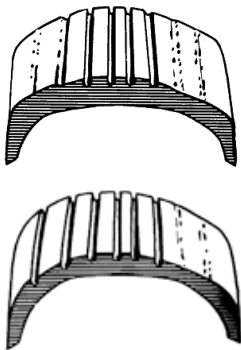
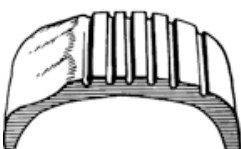
	<p>Over Inflation: Excessive wear at the center of the tread indicates that the air pressure in the tire is consistently too high. The tire is riding on the center of the tread and wearing it prematurely. Many times, this visual method of inflation (inflating the tires up until there is no bulge at the bottom) is at fault; tire inflation pressure should always be checked with a reliable tire pressure gauge.</p>
	<p>Under Inflation: This type of wear usually results from consistent under inflation. When a tire is under inflated, there is too much contact with the road by the outer treads, which wear prematurely. Tire pressure should be checked with a reliable pressure gauge. When this type of wear occurs, and the tire pressure is known to be consistently correct, a bent or worn steering component or the need for wheel alignment could be indicated. Bent steering or idler arms cause incorrect toe-in and abnormal handling characteristics on turns.</p>
	<p>Feathering: Feathering is a condition when the edge of each tread rib develops a slightly rounded edge on one side and a sharp edge on the other. By running your hand over the tire, you can usually feel the sharper edges before you'll be able to see them. The most common cause of feathering is incorrect toe-in setting, which can be cured by having it set correctly. Occasionally toe-in will be set correctly and this wear pattern still occurs.</p>
	<p>Side Wear: When an inner or outer rib wears faster than the rest of the tire, the need for alignment is indicated. There is excessive camber in the front suspension, causing the wheel to lean too much to the inside or outside and putting too much load on one side of the tire. Misalignment could be due to sagging springs, worn ball joints, worn control arm bushings or worn kingpin bushings.</p>
	<p>Cupping: Cups or scalloped dips appearing around the edge of the tread on one side or the other, almost always indicate worn (sometimes bent) suspension parts. Adjustment of wheel alignment alone will seldom cure the problem. Any worn component that connects the wheel assembly to the vehicle (ball joint, kingpins, wheel bearing, shock absorber, springs, bushings, etc.) can cause this condition. Occasionally, wheels that are out of balance will wear like this, but wheel imbalance usually shows up as bald spots between the outside edges and center of the tread.</p>

Wheels/Rims/Spiders

- Inspector shall inspect all nuts, bolts, studs, lugs and holes for damage. Visually inspect for broken, damaged, missing or loose fasteners. Rust around fasteners or on rim surface is sometimes an indication of cracked or loose mounting hardware.
- Visually inspect rim for, cracks, welds or broken components. Visually inspect for any lock or slide ring that is broken, cracked, improperly seated, sprung or has mismatched rings.

WHEELCHAIR LIFT-EQUIPPED VEHICLES

- A. Visually inspect and operate wheelchair lift to ensure proper function as designed. Inspect for any leaks that would hinder the operation of the lift.
- B. Inspect all safety systems of the wheelchair lift (e.g., hand rails, ramp stops, etc.) and ensure that they are functioning as designed and in compliance with FMVSS 403 and 404.
- C. Ensure that all pinch points are protected from seated passengers.
- D. Visually inspect all wheelchair and occupant securement devices to ensure none are missing or broken and that straps are not frayed.
- E. Inspect that all components for each wheel chair position are compatible in accordance with manufacturers' specifications.
- F. Visually and physically inspect all anchorage points, tracking and fasteners for securement.

WINDOWS

- A. Any glass or glazing that is broken through or missing (393.60);
- B. Any glass not of approved type [393.60(a)];
- C. Windshield has discoloration or other damage in that portion extending upward from the height of the topmost portion of the steering wheel, but not including a two-inch border at the top and a one-inch border at each side of the windshield or each panel thereof, except as follows:
 - 1. Color or tint applied by the manufacturer for the reduction of glare;
 - 2. Any crack not over $\frac{1}{4}$ inch long, if not intersected by any other crack;
 - 3. Any damaged area, that can be covered by a disc $\frac{3}{4}$ inch in diameter, if not closer than three inches to any other such damaged area;
 - 4. Driver's side area window(s) have chips, clouding, or cracks that obscure the driver's vision [393.60(c)]; or
- D. No operable defrosting and defogging system to clear the driver's windshield (571.103).

ALTERNATIVE FUELS

INTRODUCTION

This section is designed to be used as an overview of the alternative fuels being utilized for school transportation. It is not designed to replace current applicable federal, state, manufacturing or safety specifications that may exceed requirements within this section. There may be advancements in engineering and improvements in equipment fabrication methods and operating practices that differ from those specifically called for in this section. Such deviations or improvements may provide safety and may meet the intent of, and be compatible with, this section. Entities wishing to purchase alternative fuel school buses should use this section only as a starting point. More detailed specifications, including specific design and performance criteria and safety specifications, should be researched by prospective purchasers of alternative fuel school buses.

GENERAL REQUIREMENTS

Alternative fuel school buses shall meet the following requirements:

- A. Chassis shall meet all specifications previously mentioned in SCHOOL BUS BODY AND CHASSIS SPECIFICATIONS, this document.
- B. Chassis shall meet all applicable Federal Motor Vehicle Safety Standards (FMVSS).
- C. The fuel system integrity shall meet the specified leakage performance standards when impacted by a moving contoured barrier in accordance with test conditions specified in FMVSS No. 301, *Fuel System Integrity*, or FMVSS No. 303, *Fuel System Integrity of Compressed Natural Gas Vehicles*, as applicable.
- D. Original equipment manufacturers (OEMs) and conversion systems using compressed natural gas (CNG) shall comply with National Fire Protection Association (NFPA) Specification 52 2013, *Compressed Natural Gas Vehicular Fuel Systems*. Fuel systems using liquefied petroleum gas (LPG) shall comply with NFPA Specification 58 2014, *Liquefied Petroleum Gases Engine Fuel Systems*.
- E. Fuel tank(s) for vehicles of less than 54 passenger capacity powered by LPG or CNG shall have a minimum 40-gallon capacity. Fuel tank(s) for vehicles of 54 or more passenger capacity powered by LPG or CNG shall have a minimum 60-gallon capacity.
- F. Natural gas-powered buses may be equipped with an interior/exterior gas detection system. Natural gas-powered buses may be equipped with an automatic or manual fire detection and suppression system.
- G. All materials and assemblies used to transfer or store alternative fuels shall be installed outside the passenger/driver compartment.
- H. All Types C and D buses using alternative fuels shall meet the same base requirements of SCHOOL BUS BODY AND CHASSIS SPECIFICATIONS for passenger load.
- I. The total weight shall not exceed the vehicle's GVWR when loaded to rated capacity.
- J. The manufacturer supplying the alternative fuel equipment must provide the owner and operator with adequate training and certification in fueling procedures, scheduled maintenance, troubleshooting and repair of alternative fuel equipment.
- K. All fueling equipment shall be designed specifically for fueling motor vehicles and shall be certified by the manufacturer as meeting all applicable federal, state and industry standards.
- L. All on-board fuel supply containers shall meet all appropriate requirements of the American Society for Mechanical Engineering (ASME) code, DOT regulations or applicable FMVSSs and NFPA standards.
- M. All fuel supply containers shall be securely mounted to withstand a static force of eight times their weight in any direction.

- N. All safety devices that discharge to the atmosphere shall be vented to the outside of the vehicle. The discharge line from the safety relief valve on all school buses shall be located in a manner appropriate to the characteristics of the alternative fuel. Discharge lines shall not pass through the passenger compartment.
- O. CNG buses shall have a positive, quick-acting ($\frac{1}{4}$ turn) shut-off control valve shall be installed in each gaseous fuel supply line, as close as possible to the fuel supply containers. The valve controls shall be placed in a location easily operable from the exterior of the vehicle. The location of the valve controls shall be clearly marked on the exterior surface of the bus.
- P. An electrical grounding system shall be required for grounding of the fuel system during maintenance-related venting.
- Q. Fuel systems identified as compatible with biodiesel must be provided with components compatible with biodiesel conforming to the specifications of ASTM 6751, *Biodiesel Standard*.
- R. High Voltage-Powered Vehicles: Buses utilizing a high voltage propulsion system (more than 48 nominal volts) shall meet the requirements of FMVSS 305, *Electric Powered Vehicles: Electrolyte Spillage and Electrical Shock Protection*, except for the following:
 - 1. The propulsion power source (batteries, fuel cells, etc.) shall be located outside the passenger compartment.
 - 2. The propulsion power source enclosure shall be constructed to conform to the power source manufacturer's requirements and recommendations.
 - 3. Due to the much larger size and quantities of the propulsion power sources on larger vehicles, buses over 10,000 lbs. are permitted to exceed the 5.0-liter spillage constraint of Section S5.1, Electrolyte damage from propulsion batteries and the requirements to statically rotate the vehicle on its longitudinal axis post-test.

EQUIPMENT FOR TRANSPORTATION OF THE TRANSPORTATION OF INFANTS, TODDLERS AND PRE-SCHOOL CHILDREN

The school bus is important in the educational development of young children who have special needs because it is the mechanism for transporting them to and from support and development programs. Infants, toddlers and pre-school children with special needs present a particular challenge for transportation personnel because school buses were not designed to transport very young children as passengers. Therefore, these children present multiple challenges to providers of school bus transportation services. Nevertheless, great strides have been made in the types of equipment used to assist infants, toddlers and pre-school children with special needs to safely adapt to school bus transportation.

Challenges relating to proper installation, maintenance and use of Child Safety Restraint Systems (CSRSs), including car seats, arise. Many of these challenges are addressed in NHTSA's "Guideline for the Safe Transportation of Pre-school Age Children in School Buses" (February 1999). Bulletin 119, Vol. II: *Louisiana Student Transportation Operational Procedures* includes proper installation and use of CSRSs.

Each pre-school age school bus passenger should use a child safety restraint system appropriate for the child's age, weight, height and specialized needs, as determined by the IEP or IFSP team. Thus, a team effort is required to ensure that appropriate and proper specifications are developed for the procurement of equipment that meet the specific needs of each individual school bus passenger.

The following Federal Motor Vehicle Safety Standards are applicable in this section:

FMVSS No. 208	<i>Occupant Protection</i>
FMVSS No. 209	<i>Seat Belt Assemblies</i>
FMVSS No. 210	<i>Seat Belt Assembly Anchorages</i>
FMVSS No. 213	<i>Child Restraint Systems</i>
FMVSS No. 217	<i>Bus Emergency Exits and Window Retention Release</i>
FMVSS No. 222	<i>School Bus Passenger Seating and Crash Protection</i>
FMVSS No. 225	<i>Uniform Child Restraint Anchorages</i>

A. All CSRSs used in the school bus must...

1. Meet requirements of FMVSS No. 213;
2. Be installed, cleaned, maintained and used according to the manufacturer's instructions;
3. Not be under a recall that recommends non-use of the CSRS;
4. Have all parts intact and in working order;
5. Must not have exceeded the manufacturer's assigned expiration date;
6. Be secured to a vehicle seat with a safety belt that meets FMVSS No. 209 or anchorages to meet FMVSS No. 225 or FMVSS No. 210; and
7. Use safety belts or latch systems that are installed only on bus seats that meet FMVSS No. 210.
8. Be replaced when occupied during a school bus crash as specified by the manufacturer of the CSRS.

B. Child Safety Restraint Systems (CSRSs)

CSRSs used in school buses must be appropriate for the individual child and must be used correctly. All of the restraint systems used for transportation must be secured to the bus seat in the manner prescribed and approved by both the school bus and CSRS manufacturer.

1. Types of Restraints

a. Rear-facing CSRS (infant-only)

These seats are designed for infants from birth to twenty or twenty-two pounds (manufacturer's instructions) and who usually are less than 26 inches in length. These seats are used in rear-facing position at a 45 degree recline, which provides support to the infant's head, neck and back.

b. Convertible CSRS (Rear-Facing)

Rear-facing infant position is designed for children from birth to twenty pounds, one year of age (manufacturer's instructions), weighing up to twenty pounds and usually less than 26 inches in length. Many CSRSs are now available to accommodate larger children (30 to 35 lbs.) in the rear-facing position.

Note: See manufacturer's guidelines for weight and height restrictions. It is recommended that children ride rear-facing as long as recommended or allowed by the CSRS manufacturer.

c. Convertible CSRSs (Forward-Facing)

Forward-facing CSRSs with five-point harness, T-Shield or tray-shield are designed for children above twenty to sixty pounds. (Rear-facing position should be maintained for as long as recommended or advised by the manufacturer.) Some forward-facing-only seats are available to accommodate larger children.

Note: Some CSRSs cannot be installed properly in a twenty-inch bus seat (i.e. tray-shield and some convertible seats).

d. Car Beds

A car bed for infants up to 20 pounds allows the infant to lie flat. The use of a car bed should be predicated on the advice of a physician or an appropriate medical support professional (e.g., physical/occupational therapist) and approved by qualified personnel at an IFSP team meeting.

e. Specialized Positioning Seats

Specialized positioning seats are used only when a child does not fit in a standard CSRS or has a particular condition warranting more support.

As per NHTSA's, "*Child Passenger Safety Training Instructor Guide for School Buses*," tether straps are not required in school buses; however, some **special needs** CSRSs require a tether strap. (See manufacturer's instructions and all NHTSA curricula to determine the specifics.)

f. Safety Vests

The decision to use a vest should be made by an IFSP or IEP team that includes qualified personnel and the parent, and the use of safety vests should be noted on the IFSP or IEP. Vest selection should be appropriate for the size and needs of the child. Proper fit must account for seasonal changes in clothing.

Pre-school children, due to their age, weight, physical development and their overall mental ability, should be securely fitted with a crotch strap supplied by the manufacturer. (Only vests required under FMVSS 213 will have a crotch strap supplied by the manufacturer. It is not optional.)

Safety vests must be used **only on school bus seats**. The entire seat directly behind the child in the seat-mounted vest must be unoccupied or have restrained occupants.

Vests shall be anchored, as specified by the manufacturer.

g. Wheelchairs

All decisions regarding the use of wheelchairs in the school bus must be made by an IFSP or IEP team that includes qualified personnel and the parent and should be noted on the IFSP or IEP.

School buses must be properly equipped to accommodate wheel chairs or other mobility devices before transporting passengers who require such devices. (See the Specially Equipped School Bus Specifications section, this document.)

C. Bus Seat Designated for a Child Safety Restraint System

The transportation provider should ensure installation and use in accordance with the following NHTSA guidelines:

1. Locations of school bus seats designated for CSRSs should start at the front of the vehicle to provide drivers with quick access to the CSRS occupants.
2. CSRS anchorages on school bus seats should meet all applicable FMVSSs.
3. The non-adjustable end of the lap belt should be positioned at the center for a CSRS placed next to the window; or, at the aisle for a CSRS placed next to the aisle.
4. The non-adjustable end of the lap belt must not extend more than one to two inches from the seat.
5. When ordering new school buses, the maximum spacing specified under FMVSS No. 222, School Bus Passenger Seating and Crash Protection, (within 24 inches space from the seating reference point) is recommended for seats designated for CSRSs to provide adequate space for the CSRSs.
6. The combined width of CSRSs and/or other passengers on a single seat does not exceed the width of the seat.
7. If other students share seat positions with CSRSs, the CSRSs are placed in the window-seating position, excluding emergency exit windows.

D. Medical Equipment

All decisions regarding medical equipment in the school bus should be made in accordance with state laws and regulations. Decisions regarding medical equipment should be the joint decision of trained personnel who are knowledgeable about the type of medical assistance and support an infant, toddler or pre-school child may need while in a school bus. Decisions should be made by qualified team members in attendance at IFSP or IEP meetings, including the parent. The IFSP or IEP document should include all the appropriate information. Safe transportation specifications should be documented on the IFSP or IEP.

Some special considerations and recommendations are as follows:

1. All medical support equipment shall be secured at the mounting location to withstand a pulling force of five times the weight of the item.
2. Latched compartments are the preferred methods of transport.

3. All medical equipment should be secured below the window.
4. Oxygen equipment (liquid or gas) shall be approved by the manufacturer for transport, and should be securely mounted to the bus and fastened to prevent damage and exposure to intense heat levels.

Note: Refer to the SPECIALLY EQUIPPED SCHOOL BUS SPECIFICATIONS section.

E. Special Considerations

Because of the dependency of young children and the need to make decisions on a case-by-case basis, the following section on special considerations is provided for guidance on a variety of issues related to the transportation of infants, toddlers and pre-school children.

1. Equipment Maintenance

Procedures should be established for scheduled maintenance, cleaning and inspection of all equipment, including CSRSs. Procedures should be in place to assure that all equipment is checked regularly for recalls and for product expiration dates. Procedures must be in place for cleaning CSRSs according to manufacturers' instructions. Proper disposal of outdated equipment is important.

Note: A recall list may be found at www.nhtsa.dot.gov.

2. Radios/Two Way Communication and Cell Phones

All school buses transporting infants, toddlers and pre-school children should have two-way communications systems. Cell phones may be utilized as a communication means, when approved by the school district or Head Start agency.

APPENDIX A: TERMS AND DEFINITIONS

INTRODUCTION

This glossary was developed with three purposes in mind:

1. To provide easy access to the definition of terms used or referenced within the document;
2. To consolidate, in one resource, the acronyms, abbreviations and standard terms commonly used in the industry; and
3. To promote consistency throughout the student transportation industry by providing standard definitions or preferred usages for terms that may be used differently in different parts of the country.

The Glossary is not intended to be all-inclusive. There are and will be terms that are excluded and definitions that differ from regional usages. The Glossary is an attempt to reflect the language of student transportation, which, like all language, is ever-changing.

TERMS AND DEFINITIONS

Access panel: A body panel which must be moved or removed to provide access to one or more serviceable components.

Accessibility: The ability of vehicles or facilities to accommodate people with mobility impairments.

Accident: Any incident in which a school bus is involved that results in death, personal injury, and/or property damage, regardless of who was responsible and whether the school bus was in motion, temporarily stopped, parked, being loaded or unloaded and on public or private property. The definition applies to school buses that are being used on scheduled routes or on activity trips.

Preventable: A crash that could have been prevented by reasonable action on the part of the school bus driver.

Non-preventable: A crash in which the school bus driver did everything reasonable to prevent the accident.

Accident Reporting Form: A form used to report the occurrence of any incident that involves death, personal injury and/or property damage regardless of who was responsible. Use of the form promotes the compilation of accurate, uniform, and reliable information about school bus accidents so that problems and trends can be identified and effective safety programs can be developed or modified.

Activity bus operator: A person meeting all licensing requirements and local, state and federal regulations to operate a school bus used to transport students to and from school-related activities or on an “as-needed” basis for the LEA.

Activity trip: The transportation of students to any event sanctioned for student attendance or authorized by an officer, employee or agent of a public or private school, other than to-and-from school transportation. (See also *Field trip*.)

ADA: The Americans with Disabilities Act, PL 101-336, 42 USC 12101, et seq. When referenced in regard to student transportation, ADA generally refers to the specifications of 49 USC 38, Americans with Disabilities Act Accessibility Specification for Transportation Vehicles.

Adaptive device: Any item or piece of equipment used to increase, maintain or improve functional capabilities of children with disabilities; also known as *assistive technology device*.

Advanced EGR (A-EGR): An exhaust gas recirculation system (EGR) utilizing advanced electronic fuel management systems combined with proprietary piston bowl design and twin turbo air management systems.

Alcohol: The intoxicating agent in beverage alcohol, ethyl alcohol, or other low molecular weight alcohols, including methyl and isopropyl alcohols.

Allowable alternate vehicle: A vehicle designed for carrying eleven or more people, including the driver, that meets all the Federal Motor Vehicle Safety Standards applicable to school buses except 49 CFR 571.108 and 571.131. (See also under *Multifunction school activity bus* under *Bus*.)

Alternately flashing signal lamps: A system of red and amber signal lamps mounted horizontally both front and rear, intended to identify a vehicle as a school bus and to inform other users of the highway that the bus is about to stop or is stopped to load or unload children. The system of red and amber signal lamps is available in either sequential or non-sequential operation. Also known as school bus warning lamps, pupil warning lights, eight-light warning systems, alternately flashing warning bus safety light, school bus signal lamp, alternately flashing school bus warning lights.

Sequential operation: The system of red and amber signal lamps is designed to operate in sequence. Amber signal lamps must be activated before the red signal lamps can be activated. (Amber lamps are deactivated when the red lamps are activated.)

Non-sequential operation: The system of red and amber signal lamps is designed so that red lamps are activated whenever the entrance doors are opened, regardless of whether the amber lamps have been activated.

Alternative fuel vehicle (AFV): A vehicle designed to operate on an energy source other than petroleum-based gasoline or diesel fuel. Such fuels include, but are not limited to, CNG, LNG, LPG and electricity.

Bi-fuel: A vehicle designed to operate on two different fuels, but not simultaneously.

Dual fuel: A vehicle designed to operate on a mixture of two different fuels.

Hybrid power: The use of two or more power sources to provide the motive force for the vehicle (e.g., electricity to drive the wheels with internal combustion to supplement the battery).

Anchorage point: The point of attachment of a securement system or occupant restraint to the vehicle structure.

AMD: Ambulance Manufacturer Design.

ANPRM: Advanced Notice of Proposed Rulemaking. A notice published in the *Federal Register* by a federal agency, such as NHTSA, requesting information and inviting comment on a proposed change of regulation.

ANSI: American National Standards Institute, an organization which administers and coordinates the development of voluntary industry standards.

Antilock brakes (ABS): Brake systems with sensors that automatically control the degree of wheel slip during braking and that relieve brake pressure on wheels that are about to lock up. Also known as ABS.

ARB: The abbreviation for the (California) Air Resources Board, the state agency in California which sets the state's emission standards.

Aspect ratio: Percentage used to express the ratio of a tire's height to its width; also known as tire profile.

Assessment team: A group of persons, including the parent or guardian of a student with disabilities, who develop a profile of the student in terms of his or her mental and physical functioning in order to determine the student's eligibility for special education. (See also *MDC*.)

Assistive device (See *Adaptive device*.)

ASTM: ASTM International (originally known as the American Society for Testing and Materials); a voluntary standards development organization and a source for technical standards for materials, products, systems and services.

Attendant: A person assigned to assist one or more individual students with special needs on a school bus or school vehicle. (See also *Bus Aide*.)

BAC: Blood or breath alcohol concentration; the measure used to determine alcohol impairment.

Background check (criminal record check): The investigation of a person’s criminal history through submission of fingerprints to state and/or federal authorities.

BAT: Breath Alcohol Technician; an individual who instructs and assists persons in the alcohol testing process and operates an EBT.

Behavior management: Methods of influencing student conduct on the school bus.

BESE: (See *Board of Elementary and Secondary Education*).

Bi-fuel: Used to describe a bus capable of running on either of two fuels, although not simultaneously. Engines which can be switched to run on either CNG or gasoline are examples.

Biodiesel: Vehicle fuel made from plant or animal matter and used alone or mixed with diesel fuel in engines. B100, or “neat biodiesel,” refers to the pure form. Biodiesel can be mixed with petrodiesel in any proportion, but the most common form is B20, which is 20% biodiesel and 80% petrodiesel. Biodiesel, as defined in ASTM D 6751, is registered with the US EPA as a fuel and a fuel additive under Section 211(b) of the Clean Air Act.

Bloodborne pathogens: Common name for standards adopted by OSHA in 29 CFR 1910 to protect workers against the health hazards of exposure to blood and other potentially infectious body fluids or materials; also refers to the pathogenic microorganisms present in human blood.

Board of Elementary and Secondary Education (BESE): The administrative body for all Louisiana public elementary and secondary schools.

Boarding: The process of loading passengers into a school bus.

Body fluids cleanup kit: Package of materials including, but not limited to, latex gloves, disposal bag and absorbent material, used to clean up spills of potentially infected bodily fluids, under OSHA’s Bloodborne Pathogens regulations and Universal Precautions practices; also known as hygiene kit.

Booster seat: A firm platform, used with a lap-shoulder belt, which raises the child so that the height of his thighs and shoulders are closer to those of an adult and which helps route both portions of the lap-shoulder belt to fit the smaller body; also called belt-positioning booster.

Brake: A device or mechanism used to retard and stop the speed of a moving vehicle or to prevent the movement of a stopped vehicle.

Emergency brake: A mechanism designed to stop a motor vehicle after a failure of the service brake system.

Foundation brake: An assembly of the non-rotational components of a brake including its mechanism for developing a frictional force.

Retarder: An auxiliary braking device used to reduce brake wear and/or improve braking performance.

Service brake: The primary mechanism designed to retard and stop a moving vehicle.

Parking brake: A mechanism designed to prevent the movement of a stationary motor vehicle.

Brake fade: A condition that occurs as brakes become less effective.

BTU: A unit of work or energy known as a British Thermal Unit. One BTU is the energy required to increase the temperature of one pound of water by one degree Fahrenheit.

Bus: A motor vehicle with motive power, except a trailer, designed for carrying more than ten (10) persons, including the driver.

Charter bus: A bus that is operated under a short-term contract with a school district or other sponsor who has acquired the exclusive use of the vehicle at a fixed charge to transport students to a school-related event.

DOT bus: A school bus that meets the FMCSR standards for interstate transportation set forth in 49 CFR 390.

Intercity bus: A large bus with front doors only, high-back seats and under-floor luggage storage for high-speed, long distance trips; also known as *motorcoach* and *over-the-road coach*.

Nonconforming bus: Any vehicle designed to carry more than ten (10) passengers, including the driver that is used to transport students to or from school or school-related activities and that does not meet the federal standards specific to school buses.

School activity bus: Any motor coach other than a school bus or transit bus used for the transportation of any students enrolled in a public or private school at or below the 12th grade level, to or from school-related activities.

School bus (Federal definition): A bus owned, leased, contracted to, or operated by a school or school district, and regularly used to transport students to and from school or school-related activities, but not including a charter bus or transit bus. A school bus must meet all applicable FMVSSs and is readily identified by alternately flashing lamps, National School Bus Yellow paint, and the legend "School Bus," except as may be provided for the multifunction school activity bus.

Type A: A Type "A" school bus is a conversion or bus constructed utilizing a cutaway front-section vehicle with a left side driver's door. This definition includes two classifications: Type A-1, with a Gross Vehicle Weight Rating (GVWR) of 14,500 pounds or less; and Type A-2, with a GVWR greater than 14,500 and less than or equal to 21,500 pounds.

Type B: A Type "B" school bus is constructed utilizing a stripped chassis. The entrance door is behind the front wheels. This definition includes two classifications: Type B-1, with a GVWR of 10,000 pounds or less; and Type B-2, with a GVWR greater than 10,000 pounds.

Type C: A Type "C" school bus is constructed utilizing a chassis with a hood and front fender assembly. The entrance door is behind the front wheels; also known as a *conventional school bus*. This type also includes cutaway truck chassis or truck chassis with cab with or without a left side door and a GVWR greater than 21,500 pounds.

Type D: A Type "D" school bus is constructed utilizing a stripped chassis. The entrance door is ahead of the front wheels; also known as *rear or front engine transit style school bus*.

Multifunction school activity bus (MFSAB): "A school bus whose purposes do not include transporting students to and from home or school bus stops," as defined in 49 CFR 571.3. This subcategory of school bus meets all FMVSS for school buses except the traffic control requirements (alternately flashing signal and stop arm).

Specially equipped: A school bus designed, equipped, or modified to accommodate students with special needs.

School bus (Louisiana definition): Every motor vehicle that complies with the color, equipment and identification requirement required by law and is used to transport children to and from school or in connection with school activities, but not including buses operated by common carriers in urban transportation of school children.

School tripper bus: Any motor vehicle routed by, or in the vicinity of, a public or private school, and used for to- or from-school transportation of any student enrolled in that public or private school at or above the ninth-grade level and operated or contracted by, and under the exclusive jurisdiction of, a publicly owned or operated transit system.

Transit bus: A bus designed for frequent stops, with front and back-center doors and low-back seating, operated on a fixed schedule and route to provide public transportation by indiscriminately taking on passengers at designated bus stops.

Bus aide: (See *Attendant*.)

Bus body: The portion of a bus that encloses the occupant space exclusive of the bumpers, the chassis frame, and any structure forward of the forward-most point of the windshield mounting.

Bus pass: Authorization to ride a school bus other than the student's assigned bus; or prepayment for transit bus rides.

Bus yard: An area for storage and maintenance of buses.

CAA: Clean Air Act; also known as CAAA, the Clean Air Act Amendments of 1990.

Cam wrap: A seat-mounted system for attaching a safety harness to a school bus seat.

Cancellation (driver's license): A driver's license is annulled because of some error or defect or because the licensee is no longer entitled to such license, but the cancellation of a license is without prejudice, and application for a new license may be made at any time after such cancellation.

Capacity (See *Seating capacity*.)

Capital costs: Long-term costs associated with the purchase of vehicles, buildings and property.

Captive: Refers to a non-removable attachment, part or fitting on a securement system.

Carbon monoxide: A product of incomplete combustion; this gas is colorless, odorless, very poisonous and does not contribute to smog.

Carrier: Any public school district, any public or private educational institution providing preschool, elementary or secondary education, or any person, firm or corporation under contract to such a district or institution, engaged in transporting students.

Casualty insurance (See *Liability insurance*.)

Catalytic converter: An exhaust after-treatment device containing a catalytic material that is used to burn off or reduce unburned fuel or gases and thus reduce emissions, particularly NOx and hydrocarbons. Diesel converters run at cooler temperatures than gasoline converters and require different catalysts.

CDIP: Commercial Drivers Instructional Permit. The learner's permit that a CDL applicant receives when he/she passes the knowledge tests; it allows the applicant to drive a CMV when accompanied by a driver with a CDL.

CDL: Commercial Driver's License, which is required by federal and state laws to operate specific commercial motor vehicles.

Cetane number: A measure of self-ignition properties of a fuel after injection in a diesel engine. It relates to the knock properties of fuel. The higher the number, the more easily the fuel will ignite under compression; therefore, higher cetane fuels are usually preferred in diesel engines.

CFR: Code of Federal Regulations.

Chain of custody: The chronological handling, documentation, or paper trail showing receipt, custody, control, or transfer of students or items (such as medication).

Chassis: Vehicle frame with all operating parts, including engine frame, transmission, wheels and brakes.

Chassis starting interlock circuit: A device which prevents the engine of a bus from starting if any of the emergency exits are locked or not fully closed and latched.

Clean diesel: A combination of improved emission controls and cleaner-burning diesel fuel (see *ULSD*) that significantly reduces the pollutants from diesel engines. Can refer to new vehicles that meet EPA's 2007 or 2010 standards or to older vehicles retrofitted with emission control technology.

CMV: Commercial Motor Vehicle. A motor vehicle defined in 49 CFR 390.5.

CMVSA: Commercial Motor Vehicle Safety Act of 1986; among other things, authorization for CDL.

CNG: Compressed natural gas.

Combustible gas sensor: Detector capable of sensing the presence of natural gas.

Commercial Motor Vehicle (49 CFR 390.5): Any self-propelled or towed motor vehicle used on a highway in interstate commerce to transport passengers or property when the vehicle—

- A. Has a gross vehicle weight rating or gross combination weight rating, or gross vehicle weight or gross combination weight, of 4,536 kg (10,001 pounds) or more, whichever is greater; or
- B. Is designed or used to transport more than 8 passengers (including the driver) for compensation; or
- C. Is designed or used to transport more than 15 passengers, including the driver, and is not used to transport passengers for compensation; or
- D. Is used in transporting material found by the Secretary of Transportation to be hazardous under 49 U.S.C. 5103 and transported in a quantity requiring placarding under regulations prescribed by the Secretary under 49 CFR, subtitle B, chapter I, subchapter C.

Common carrier: A public bus, train or airplane that travels on a prescribed route and schedule, and accepts passengers indiscriminately.

Communicable disease: Any illness that can be transmitted from one person to another, including most common childhood diseases, the common cold and serious illnesses, such as hepatitis and AIDS.

Community transportation: Services that address all transit needs of a community, including general and special populations, such as the elderly and disabled.

Companion animal: An animal trained to provide assistance for persons with disabilities; can be a guide animal, assistive animal or service animal.

Completed vehicle: A vehicle that requires no further manufacturing operation to perform its intended function other than the addition of readily attachable components, such as mirrors or tire and rim assemblies, or minor finishing operations such as painting.

Conduct report: A form authorized by school officials for use by drivers to report instances of unacceptable behavior by school bus passengers; also known as *discipline report*.

Continuum of services: The range of possible options, from least restrictive to most restrictive,

available to students with disabilities for transportation services.

Conspicuity: The ability of an object to be noticed and recognized without any confusion or ambiguity (SAE J1967).

Controlled-Access Highway: Every highway, street, or roadway in respect to which owners or occupants of abutting lands and other persons have no legal right of access to or from the same except at such points only and in such manner as may be determined by the public authority having jurisdiction over such highway, street, or roadway.

Convicted (Conviction): Includes the entry of a plea of guilty or nolo contendere to a felony offense.

COWHAT: Committee on Wheelchairs and Transportation: a group comprised of safety experts, rehabilitation engineers, clinicians, manufacturers and other stakeholders who work under the auspices of RESNA to develop voluntary equipment standards related to providing safer transportation for wheelchair-seated occupants of motor vehicles.

Crash, school bus: (1) A motor vehicle collision involving a school bus with or without a student on board, resulting in any personal injury or death or any disabling damage to one or more motor vehicles requiring the vehicle(s) to be transported away from the scene by a tow truck or other vehicle; or (2) A collision involving any vehicle with any student or with a school bus at any time during the loading or unloading process. (See also *Accident*.)

Preventable: A crash that could have been prevented by reasonable action on the part of the school bus driver.

Reportable: A crash required to be reported under FMCSR (i.e., a crash involving a CMV on a public road in which there is a fatality or an injury treated away from the scene, or that requires a vehicle to be towed from the scene).

Crash test (See *impact test*.)

Criminal record check (background check): The investigation of a person's criminal history through submission of fingerprints to state and/or federal authorities.

Crossing control arm (crossing gate): A device attached to the front bumper of a school bus that is activated during loading and unloading and designed to force the students to walk far enough away from the front of the bus to be seen by the driver.

Cross-Walk:

- A. Part of a roadway at an intersection included within the connections of the lateral lines of the sidewalks on opposite sides of a roadway measured from the curbs or, in absence of curbs, from the edges of the traversable roadway;
- B. Any portion of a roadway at an intersection or elsewhere distinctly indicated for pedestrian crossing by lines or other markings on the surface.

Cryogenic: Relates to storage and use at very low temperatures. LNG requires cryogenic systems.

CSRS: Child Safety Restraint System; a device (other than lap or lap/shoulder seatbelts) meeting the requirements of FMVSS No. 213, designed for use in a motor vehicle to restrain, seat or position a child who weighs 30 kg (66 lbs) or less; also known as *child safety seat* and *car seat*.

Curb cut: Area where the street curb has been cut and sloped to allow the sidewalk to lead smoothly to the roadway.

Curb weight: The weight of a motor vehicle with standard equipment, maximum capacity of engine fuel, oil, and coolant and, if applicable, air conditioning and additional weight of optional engine, but without passengers.

Danger zone: A twelve-foot area immediately surrounding the stopped school bus.

Deadhead: Movement of a bus without passengers (e.g., from school to bus yard).

Deadtime: The period between arriving at an activity trip destination and leaving the destination for the trip home; also known as *waiting time* and *stand-by time*.

Dealer: Any person who is engaged in the sale and distribution of new motor vehicles or motor vehicle equipment. Refers primarily to vendors who, in good faith, sell any such vehicle or equipment for purposes other than resale.

Decibel (dB): A unit used to express the relative intensity of a sound as it is heard by the human ear. The decibel measuring scale is logarithmic. Zero (0 dB) on the scale is the lowest sound level that a normal ear can detect under very quiet (“laboratory” conditions) and is referred to as the “threshold” of human hearing. On a logarithmic scale, 10 decibels are 10 times more intense, 20 decibels are 100 times more intense, and 30 decibels are 1,000 times more intense than 1 decibel.

Decibel “A-Weighted” (dBA): The scale for measuring sound in decibels that assigns weights to different frequency ranges to reduce the effects of low and high frequencies in order to simulate human hearing.

DEF: Diesel Exhaust Fluid; the reactant necessary for the functionality of the SCR system. It is prepared by dissolving solid urea to create 32.5% solution in water. DEF breaks down into ammonia (NH₃) and reacts with NO_x in the SCR system to produce Nitrogen (N₂) and water (H₂O).

Distributor: Any person or company primarily engaged in the sale and distribution of motor vehicles or motor vehicle equipment and/or parts for resale.

Dispatch: To relay service instructions to drivers.

Divided Highway: Any highway divided into roadways by a median, physical barrier, or clearly indicated dividing section so constructed as to impede vehicular traffic.

DNR: Do Not Resuscitate; an order from a parent, legal guardian or court that prohibits the use of emergency measures to prolong the life of an individual.

DOC: Diesel oxygenation catalyst. Devices that use a chemical process to break down pollutants in the exhaust stream of diesel engines into less harmful components.

DOE: Department of Education

DOT: United States Department of Transportation.

DOT driver: A driver who meets the FMCSA standards, set forth in 49 CFR 391.

Double run: One bus making two trips over the same route each morning and afternoon (e.g., first picking up high school students and then returning for elementary students).

Downtime: The period when a vehicle is not in service (e.g., due to mechanical failure or scheduled maintenance).

DPF: Diesel particulate filter; ceramic devices that collect particulate matter in the exhaust stream of diesel engines. The high temperature of the exhaust heats the ceramic structure and allows the particles inside to break down (or oxidize) into less harmful components.

Driver: A person who drives or is in actual physical control of a vehicle.

Driver, school bus: (See *Operator, school bus*, for Louisiana definition.)

Driver applicant: A person who applies for a position as a school bus driver.

Driver training: Instructional program designed to impart knowledge and improve the skills necessary for school bus drivers, including but not limited to knowledge of the vehicle, safe driving practices, emergency procedures and passenger control.

In-service: Training provided annually, or more often, to school bus-certified drivers.

Pre-service: Training provided to driver applicants prior to school bus certification and/or transporting students.

Driver qualifications: Restrictions of state and federal law which determine a person's eligibility to become a school bus driver (e.g., age limits, physical condition, criminal record, driving history, etc).

Driver's license, or license (Louisiana): Any license secured from the Louisiana Department of Public Safety and Corrections, Office of Motor Vehicles, to operate a motor vehicle on the highways of Louisiana.

DRL: Daytime running lamps; head lamps that operate automatically at a reduced voltage during the day to increase the vehicle's visibility; also known as *daytime running lights*.

Drug: Any substance other than alcohol considered to be a controlled substance listed on schedules I through V in 21 CFR 1308.

Dry run: A trip on a route without student passengers for driver training or familiarization of the route.

Dual brake system (See *Split brake system*.)

Dual fuel engine: Also known as *flex fuel*. Used to describe a gasoline-methanol dual fuel engine using mixtures of gasoline and methanol, such as M85, which is 15 percent gasoline and 85 percent methanol. Dual-fuel engine can also refer to engines operating on any other mixture of fuels simultaneously, such as engines which run on a mixture of CNG and diesel.

DVIR: Driver vehicle inspection report. Federal, state or local approved form for reporting results of pre-trip and post-trip inspections; also known as *daily vehicle inspection report* and *pre-trip inspection form*.

Dynamic testing: The process of subjecting vehicle, mobility aid, or mobility aid/securement system components to a simulated crash condition.

EAP: Employee Assistance Program; a program of education and counseling required by 49 CFR 391 as part of a carrier's drug and alcohol testing program; may also include optional rehabilitation services.

EBT: Evidential Breath Testing device; a device approved by NHTSA for testing drivers for alcohol use.

EDR: Event Data Recorder; a device which records vehicle functions (e.g. speed change during a crash).

EGR: Exhaust Gas Recirculation; A type of in-cylinder NOx reducing technology that involves the reintroduction of metered quantities of cooled exhaust gas back into the cylinder as it fills with air, displacing some of the air volume and hence some of the oxygen. Replacing a proportion of this oxygen reduces the NOx formed during combustion.

EHA: The Education for all Handicapped Children Act, passed in 1975 as P.L.94-142. (See also IDEA.)

EPA: The United States Environmental Protection Agency.

Early bus: A bus scheduled to run prior to the regular morning run (e.g. to take children to day care programs located in schools).

Early intervention service: Education and related services provided to infants and toddlers from birth through two years of age.

Effective date: The date at which a regulation or standard takes effect, on or after which compliance is legally required.

Elastomer: An elastic substance occurring naturally, as natural rubber, or produced synthetically (e.g., butyl rubber, vinyl, etc.).

Electronic voice communication system: A means by which the driver of a vehicle can communicate with a dispatcher or other person at a remote location (e.g., two-way radio, cellular phone).

Emergency roof exit: An opening in the roof of the bus meeting the requirements of FMVSS No. 217 which provides emergency egress and sometimes ventilation; also known as *roof hatch*.

Emergency Evacuation Drill Verification form (Form T-8): The form used to verify that emergency drill procedures have been taught to passengers and emergency drills were conducted for all students in each public school. The form must be completed at the beginning of each semester and submitted to the district transportation office. (See sample Forms T-8 and T-9 in Bulletin 119, Supplement II, Appendix B.)

Emergency response plan: A detailed approach to identifying and responding to potential accidents involving hazardous substances; required for every community by the Emergency Planning and Right-to-Know Act of 1986.

Employee Notification form: The form used by a school bus operator, in compliance with provisions of the Commercial Motor Vehicle Safety Act of 1986, to report to the operator's employer(s) the operator's conviction of a moving violation while driving any motor vehicle. (See sample Employee Notification Form in Bulletin 119, Supplement II, Appendix B.)

EOBR: Electronic on-board recorders; an electronic device that collects, stores, and displays data relative to driver and vehicle performance, including such elements as location, time, speed, and distance traveled.

Ergonomics: The study of the design of equipment to reduce human fatigue and discomfort.

Ethanol: Grain alcohol, distilled from fermented organic matter and used as a vehicle fuel.

Evacuation drill: Performance of a mock school bus evacuation in order to teach students proper emergency procedures and to provide practice in the use of emergency exits; also known as *bus safety drills*.

Extended-year service: Transportation provided for students subsequent to the end of the traditional school year; especially, transportation as a related service for students with disabilities beyond the normal school year in accordance with the IEP.

Extra-board driver (See *Substitute driver*.)

FAPE: Free Appropriate Public Education; it refers to special education and related services, including transportation, provided at public expense in accordance with a child's IEP (34 CFR 300.13 and 300.121).

FBI background check: The national criminal record check.

FCC: Federal Communications Commission

Feeder trip (run): Transportation of students in private vehicles or means other than conventional school bus to designated pick-up point on a route, trip or run. Feeder trip drivers are not paid as regular school bus drivers [R.S.17:496(C)].

FERPA: The Family Educational Rights and Privacy Act of 1974, 20 USC 1232, which requires confidentiality of student records in public schools, but allows access to necessary information regarding student disabilities and/or health needs to those who have a need to know, including school bus drivers.

FHWA: Federal Highway Administration; an agency of the U.S. Department of Transportation.

Field trip: The transportation of students to an event or destination which is an extension of classroom activity (i.e., a part of the curriculum). A field trip is one type of *activity trip*.

Final Rule: Notice published in the *Federal Register* by a federal agency announcing a new or changed regulation.

Final stage manufacturer: A person who performs such manufacturing operations on an incomplete vehicle that it becomes a completed vehicle.

First aid: Emergency treatment given to an ill or injured person before regular medical help is available.

Fixed route: Transportation service that runs on regular, prescheduled routes, usually with bus schedules and designated bus stops.

FMCSA: Federal Motor Carrier Safety Administration; an agency of the U.S. Department of Transportation; formerly the Office of Motor Carrier Highway Safety within the Federal Highway Administration.

FMCSR: Federal Motor Carrier Safety Regulations, 49 CFR 383, 390-397, and 399; motor vehicle safety and construction standards under FMCSA that apply to commercial motor vehicles and drivers transporting passengers in interstate commerce.

FMLA: Family and Medical Leave Act; requires employers to grant time off to employees for medical reasons or to care for family members.

FMVSSs (49 CFR 571): Standards (written and enforced by the National Highway Traffic Safety Administration of the U.S. Department of Transportation) to which manufacturers of new motor vehicles and related equipment items must conform and certify compliance. FMVSSs are written in terms of minimum safety performance requirements.

Formaldehyde: A chemical compound that is a by-product of combustion from engines. Concentrations may be particularly high in emissions from engines fueled by methanol.

Forward control bus: a school bus in which more than half of the engine length is rearward of the foremost point of the windshield base and the steering wheel hub is in the forward quarter of the vehicle length; also known as *transit-style*. (See also *school bus*, type D.)

Forward-facing: Installation of a seat (fixed bus seat or secured mobile seating device) in such a way that the seat and its occupant face the front of the vehicle when secured.

Four-point tiedown: A securement system in which four strap assemblies attach to the wheelchair frame at four separate points and anchor to the vehicle floor at four separate points.

FSS: Fire suppressant system; a fire extinguisher system installed in the engine compartment of a vehicle and activated automatically in response to a fire sensor or manually in response to an alarm.

FTA: Federal Transit Administration, part of U.S. Department of Transportation; formerly Urban Mass Transit Administration (UMTA).

Fuel injection: System that uses no carburetor but sprays fuel directly into cylinders or into the intake manifold.

Fumigate: Literally means “to form a gas or disperse one gas in another.” The term is used to describe the injecting of gas, usually CNG, into the intake air of the engine.

Glazing: The glass or glass-like portion of a window.

Laminated glass: Any glazing material that consists of one or more sheets of glass and an inboard-facing surface sheet of plastic, the components being held together by intervening plies of plastic interlayer or by the self-bonding characteristic of the inboard plastic layer.

Safety glass: Glazing material constructed, treated or combined with other materials so as to reduce, in comparison with ordinary glass, the likelihood of injury to persons as a result of contact with the glass, either broken or unbroken.

Storm window: Two or more sheets of safety glazing material separated by airspace to provide insulating properties and fixed in a common frame or mounting.

Tempered glass: Glazing which consists of glass that has been tempered to meet the properties of safety glass.

GAWR: Gross axle weight rating; the value specified by the manufacturer as the load-carrying capacity of a single axle system, as measured at the tire-ground interfaces.

GPS: Global Positioning System; a satellite tracking system that enables a receiver to compute the position and speed of a vehicle.

Greenhouse gases: some of these gases are formed by vehicle emissions causing a rise in temperature of the earth's atmosphere.

Guideline 17: A highway safety program guide for student transportation safety issued by NHTSA in 23 CFR 1204; formerly Standard 17.

GVWR: Gross vehicle weight rating; the value specified by the vehicle manufacturer as the load-carrying capacity of a single vehicle as measured at the tire-ground interfaces. For school buses, NHTSA has defined in Title 49 CFR, Section 567.4(g)(3), the minimum occupant weight allowance as 120 pounds per passenger times the number of the vehicle's designated seating positions and 150 pounds for the driver. Gross vehicle weight rating shall not be less than the sum of the unloaded vehicle weight, plus the rated cargo load.

GVW: Gross vehicle weight; the actual weight of the fully loaded vehicle, including all cargo, fluids, passengers and optional equipment as measured by a scale.

Handrail inspection tool: A device formed by tying a half-inch hex nut to a 36-inch cord, used to inspect school bus handrails and other areas for possible snagging hazards.

Hazard lamps: Lamps that flash simultaneously to the front and rear on the right and left sides of a vehicle, used to indicate caution; also known as *four-way flashers*.

Head protection zone: The empty space above and in front of each school bus passenger seat which is not occupied by side wall, window or door structure, the dimensions of which are detailed in FMVSS No. 222.

Head Start: A program initiated in 1965 to provide comprehensive child development services to preschool children of predominantly low-income families.

Headsign: A sign above the windshield of the bus which can be changed from School Bus to other wording, such as *Charter*.

Health care plan: A plan of action used to outline the care for a medically fragile individual.

Highway (Louisiana): The entire width between the boundary lines of every way or place of whatever nature publicly maintained and open to the use of the public for the purpose of vehicular travel, including bridges, causeways, tunnels and ferries; synonymous with the word street.

Horsepower: The measurement of an engine's ability to do work. One horsepower is the ability to lift 33,000 pounds one foot in one minute.

Hours of service: The consecutive or cumulative period of time that a commercial driver may be on duty; for details see reference in the sub-section, "Transportation Other Than To and From School" in the OPERATIONS section of this document.

HOV: High occupancy vehicle; a vehicle that can carry two or more passengers.

Hybrid vehicle: Generally refers to a vehicle designed to run on electric power and an internal combustion engine.

Hydrogen fuel cell: A chemical reaction process to develop electrical current from oxygen and hydrogen.

Hydrocarbons: A gaseous compound formed by incomplete combustion and comprised of unburned and partially burned fuel. It combines with NOx and sunlight to form ozone and is a major contributor to smog.

ICC: The former Interstate Commerce Commission, the economic regulation agency within the Department of Transportation. The agency was disbanded in 1997 as a result of economic deregulation, and most functions were transferred to the Federal Highway Administration.

ICS: Incident Command System.

IDEA: The Individuals with Disabilities Education Act, passed in 1990 as P.L. 101-476, to replace the EHA (20 USC 1400 *et. seq.*); also the regulations at 34 CFR Parts 300 and 303.

IEP: Individualized Education Program; a written statement developed by an assessment team for each child with a defined disability, as required under IDEA.

IFSP: Individualized Family Service Plan; a written plan for providing early intervention services to an eligible child and his or her family under Part H of IDEA.

Impact test: A simulated crash condition which evaluates the ability of a vehicle or any component or device to withstand crash forces; also known as *sled test* and *crash test*.

Inclusion: Integration of a student with disabilities into a regular classroom and onto a regular school bus; also known as *mainstreaming*.

Incomplete vehicle: An assemblage consisting, as a minimum, of frame and chassis structure, power train, steering system, suspension system and braking system (to the extent that those systems are to be part of the completed vehicle) and requiring further manufacturing operations other than the addition of readily attachable components, such as mirrors and tire and rim assemblies, or minor finishing operations such as painting, to become a completed vehicle.

Incomplete vehicle manufacturer: A manufacturer of an incomplete vehicle (i.e., a person who performs the first stage of manufacture on a vehicle manufactured in two or more stages of manufacture). (See also *intermediate manufacturer* and *final-stage manufacturer*.)

Injury incident, school bus: Any non-crash event resulting in injury to a person while in the bus or while boarding/leaving the bus.

In loco parentis (See *Loco parentis*.)

Inspection: A close examination of a motor vehicle performed in accordance with local, state and/or federal requirements by an authorized agent of the local, state or federal government.

Integrated restraint system: A system in which the occupant restraint for an individual in a wheelchair/mobility aid connects directly to, and is dependent upon, the rear strap assemblies of the mobility aid's securement system.

Intermediate manufacturer: A person, other than the incomplete vehicle manufacturer or the final-stage manufacturer, who performs manufacturing operations on an incomplete vehicle.

International symbol of accessibility: A white emblem on blue background used to indicate that a vehicle can accommodate individuals with disabilities.

Intersection:

- A. The area embraced within the prolongation or connection of the lateral curb lines, or, if none, then the lateral boundary lines of the roadways of two highways which join one another at, or approximately at, right angles, or the area within which vehicles traveling upon different highways joining at any other angle may come in conflict;
- B. The area where a highway includes two highways thirty feet or more apart, then every crossing of each highway of such divided highway by an intersecting highway shall be regarded as a separate intersection. In the event such intersecting highway also includes two highways thirty feet or more apart, then every crossing of two highways of such highways shall be regarded as a separate intersection;
 - 1. The junction of an alley with a street or highway shall not constitute an intersection.

Interstate Highway: A fully controlled access highway which is a part of the National System of Interstate and Defense Highways.

ITP: Individualized Transportation Plan; a plan established to transport a student with a defined disability.

Kneeling bus: A bus on which the front or rear end is lowered to allow easier access for passengers with disabilities.

Laned Roadway or Highway: A roadway or highway that is divided into two or more clearly marked lanes for vehicular traffic.

Lap belt: A Type 1 belt assembly meeting the requirements of FMVSS No. 209 and intended to limit movement of the pelvis.

Lap/shoulder belt: A Type 2 belt assembly meeting the requirements of FMVSS No. 209 and intended to limit the movement of the pelvis and upper torso.

Lap tray: An accessory for a wheelchair or other mobile seating device, to offer support and convenience for the occupant.

LATCH system: Lower Anchors and Tethers for Children system; incorporates standardized hardware in vehicle seats including the lower anchorages and the upper tether anchorage. It is designed to allow installation of CSRS without using the vehicle's seat belt system. All CSRSs sold in the US after 2002 are required to be LATCH compatible.

Late bus: A bus scheduled to leave school at a time subsequent to the end of the school day, usually to provide transportation for students involved in after-school activities.

Layover time: Time built into a trip schedule between arrival and departure.

LEA: See *Local Education Agency*.

Lean burn: Uses more air than is needed for theoretical complete combustion. This added air allows combustion to take place at a lower temperature, thus reducing the emission of NOx and CO.

LED: Light emitting diode; an electronic semiconductor device that emits light when an electric current passes through it. LEDs are commonly used in lamps and digital displays.

Left: Left position is determined from the normal driving position as seated in the driver's seat looking in the direction of forward travel.

Length (of a school bus body): For the purpose of determining base pay (salary) and operational pay for school bus owner/operators (R.S. 17:496, R.S. 17:497), the length of the school bus shall be determined by measuring the bus body from the base of the front windshield to the exterior of the bus body.

Liability insurance: Protection against the claims of others for injury or property damage; also known as *casualty insurance*.

Life cycle procurement: A procurement contract based on both the initial capital cost and the cost of operation over the life of a vehicle, intended to identify the most cost-effective time to replace an asset.

Lift (See *Power lift*.)

Live time: The time when students are in the bus, beginning when the first passenger boards and ending when the last passenger leaves.

LNG: Liquefied Natural Gas.

Load (noun): The combined number of passengers on a school bus at a given time.

Load (verb): To pick up students at a designated bus stop or at school.

Load factor: The ratio of passengers actually carried to the vehicle's passenger capacity.

Loading zone: Any area where students are boarding or leaving a school bus.

Local Education Agency: A school or school district having authority over the administration of a school or a group of schools.

Loco parentis: (also in *loco parentis*); legal term meaning the formal authority of a person to act for or in place of the parent of a minor child.

Low-bid procurement: Competitive procedure in which the lowest bidder is awarded the contract. (See also *performance-based procurement*.)

Low-floor vehicle: A bus in which the floor and entrance are closer to the ground, for easier access by students with disabilities or pre-schoolers.

Longitudinal: Parallel to the longitudinal centerline of the vehicle, front to rear.

LPG: Liquefied Petroleum Gas; also known as propane.

LRE: Least Restrictive Environment; a concept embodied in IDEA which requires that children with disabilities be integrated as fully as possible into situations and settings with their non-disabled peers.

Mainstreaming (See *inclusion*.)

Manufacturer: Any person engaged in the manufacturing or assembling of motor vehicles or items of motor vehicle equipment, including any person importing motor vehicle equipment for resale.

MDC: Multi-Disciplinary Conference; an assessment meeting for a student with disabilities which leads to an IEP. (See also *assessment team*.)

MDT: Multi-Disciplinary Team; also known as PET, Pupil Evaluation Team: (See also *Assessment team*.)

Mediation: Efforts by a third party to bring about agreement between dissenting parties (e.g., labor

and management or parents and school administration); usually less formal than arbitration.

Medical support equipment: Portable equipment used by students to maintain life functions, such as oxygen bottles, intravenous or fluid drainage apparatus.

Medically fragile: Refers to students who require specialized technological health care procedures for life support and/or health support.

MFSAB (See *Multifunction school activity bus* under *Bus*.)

Minibus: A small school bus, usually a Type A-1 or A-2 or Type B-1 or B-2.

Minivan: A multi-purpose vehicle (MPV) designed to carry seven to ten passengers.

Mirrors: The system of mirrors required to be installed on school buses in accordance with FMVSS No. 111 and applicable state laws.

Crossview: Convex mirrors mounted on the front of the school bus and designed for student detection during loading and unloading, also known as System B mirrors and including elliptical, quadri-spherical, banana, or standard convex mirrors.

Driving: Flat and convex mirrors mounted on each side of the bus designed for viewing the road along the sides to the rear while driving; also known as rearview, double nickel, west coast, or System A mirrors.

MIS: Management Information System; a means of data collection for analysis by management.

Mobility aid: A wheelchair, walker, crutch, cane or other device that is used to support and help convey a person with a physical disability.

Mobile Seating Device: A mobility aid designed to support a person in the seated position.

Modesty panel: A panel located in front of a seat or row of seats to preserve the modesty of the passengers, usually supported by a stanchion and cross bar, and does not meet the performance standards of a *barrier* as defined in FMVSS No. 222. Also, a short panel which extends from the bottom of a barrier to or near to the floor for the purpose of reducing the draft from the entrance door—also known as *kick panel*.

Monitor: Especially Head Start (45 DFR 1310), a person assigned to assist the school bus driver to control behavior of students in the bus and/or to ensure the safety of students getting on and off the bus and to check the loading zone before the driver pulls out.

Motor carrier (or Carrier): Any person owning, controlling, managing, operating, or causing to be used or operated any commercial motor vehicle used in the transportation of persons or property over the public highways of Louisiana.

Motor vehicle: Every vehicle which is self-propelled and every vehicle which is propelled by electric power obtained from overhead trolley wires, but not operated upon rails, but excluding a motorized bicycle. Motor vehicle shall also include a “low-speed vehicle” which is a four-wheeled, electric-powered vehicle with a maximum speed of not less than twenty miles per hour but not more than twenty-five miles per hour and is equipped with the minimum motor vehicle equipment appropriate for vehicle safety as required in 49 CFR 571.500.

MPV: Multipurpose Passenger Vehicle; any vehicle with a seating capacity of ten or fewer, including the driver, which is built on a truck chassis or with special features for occasional off-road use.

MRO: Medical Review Officer; a licensed physician with knowledge of substance abuse disorders required by 49 CFR 40 to receive and evaluate laboratory results generated by a carrier’s drug testing program.

Multiple-Lane Highway: Any highway with two or more clearly marked lanes for traffic in each direction.

MVR: Motor Vehicle Record of the driver; also known as *driving history*.

NAPT: National Association for Pupil Transportation; a membership organization comprised of individuals and organizations representing all facets of school transportation.

NASDPTS: National Association of State Directors of Pupil Transportation Services; a membership organization primarily comprised of state officials responsible for student transportation.

National school bus yellow: The color defined in the publication “National School Bus Color Standard” SBMTC-008.

NDR: National Driver Registry.

Nebula combustion chamber: A unique high-turbulence combustion chamber in the top of a piston, which is particularly effective in efficient burning of lean gas-air mixtures.

Neutral safety switch: A device which prevents the bus from starting unless the transmission is in neutral gear or the clutch is depressed.

NFPA: National Fire Protection Association.

NGV: Natural Gas Vehicle.

NHTSA: The National Highway Traffic Safety Administration is the agency of the Executive branch of the United States Department of Transportation that is charged with writing and enforcing safety, theft resistance, and fuel economy standards for motor vehicles.

NIMS: National Incident Management System.

NIST: National Institute of Standards and Technology.

NOx: Oxides of Nitrogen; a regulated diesel emission which is a collective term for gaseous emissions composed of nitrogen and oxygen.

Nominal dimension: A dimension which exists in name only (e.g. 5/8” plywood, which is actually 19/32” thick, but is 5/8” nominal thickness). The variation between the actual dimension and the nominal dimension is the result of manufacturing practices and tolerances.

Non-conforming van: A vehicle smaller than a bus, designed to carry seven to ten passengers including the driver, and used to transport students, that does not meet FMVSS for school buses.

Non-preventable crash or incident: Any incident in which a school bus driver did everything reasonable to prevent the crash or incident.

NPRM: Notice of Proposed Rulemaking; a notice published in the *Federal Register* by a federal agency of a proposed change in regulation.

NSC: National Safety Council.

NSBY: National School Bus Yellow: (See also SBMTC-008 for colorimetric specifications.)

NSTA: National School Transportation Association, a membership organization comprising primarily school transportation contractor companies.

NSTSP: National School Transportation Specifications and Procedures; a publication of the National Congress on School Transportation.

NTSB: National Transportation Safety Board, an independent federal agency authorized by Congress to investigate accidents and to issue safety recommendations.

Occupant: A person who occupies space inside a school bus; refers to both passenger and driver.

OCR: Office of Civil Rights, an agency of the U.S. Department of Education.

Octane number: A measure of anti-knock properties of a fuel that relates to spark ignition engines. The higher the number, the more resistant to knocking. Higher output and more efficient engine designs can be used with higher octane fuel.

OEM: Original Equipment Manufacturer.

On-board monitoring system: Computerized tracking of driver and vehicle performance, including speed, fuel consumption, etc. (See also *EOBR*.)

One-mile measurement (for determining student eligibility for school bus transportation): Walking distance from student's driveway or entrance to the nearest public road to the walking entrance of the school building. The distance shall be measured by the most direct route and may be along roads or walkways.

Operating costs: All costs associated with running the transportation system, which are distinct from capital costs.

Operator: The carrier who is responsible for running the transportation system, regardless of ownership of the vehicle.

Operator*, School Bus: The term school bus operator, as used in (R.S. 17:150), shall mean any individual who operates a school bus transporting children under the supervision of the public school system of the state of Louisiana. (***Note:** The Louisiana Legislature, in 2017, revised statutes that referred to *school bus drivers to school bus operators*, thus making the terms synonymous.)

Operator's License or License: Any license secured from the Department of Public Safety and Corrections, Office of Motor Vehicles for the purpose of operating a motor vehicle on the highways of Louisiana.

OSEP: Office of Special Education Programs; an agency of the U.S. Department of Education.

OSERS: Office of Special Education and Rehabilitative Services; an agency of the U.S. Department of Education.

OSHA: Occupational Safety and Health Administration, an agency of the U.S. Department of Labor.

OTETA: The Omnibus Transportation Employees Testing Act of 1991, requiring drivers holding CDLs to participate in a drug and alcohol testing program.

Out of service: The removal of a school bus from passenger service due to a defective condition.

Overall vehicle width: The nominal design dimension of the widest part of the vehicle, exclusive of signal lamps, marker lamps, outside rearview mirrors, flexible fender extensions and mud flaps, determined with the doors and windows closed and the wheels in the straight-ahead position.

Overhang: The distance from the center of the rear axle to the rearmost end of the body or from the center of the front axle to the forward edge of the front bumper.

Owner: A person who holds a legal title to a vehicle or, in the event a vehicle is the subject of an agreement for the conditional sale, lease, or transfer of possession thereof with the right of purchase upon the performance of the conditions stated in the agreement, with the right of immediate possession in the vendee, lessee, or possessor.

Ozone: A pollutant formed from nitrogen oxides (NO_x), hydrocarbons and sunlight. This gas has an irritating odor, is poisonous and is used as an oxidizing agent for bleaching.

P. A. system: A public address system which allows the driver of a bus to communicate with persons inside and/or outside the bus through a speaker installed on the inside and/or outside of the bus; also known as *external loudspeaker*.

Parallel restraint system: A system in which the occupant restraint lap belt anchors directly to the floor track or plates, and is independent of the wheelchair/mobility aid securement system.

Paratransit: Public transit service which is more flexible than a fixed-route system, commonly providing special service for elderly and disabled passengers.

Park (or Parking): The standing of a vehicle, whether occupied or not, otherwise than temporarily for the purpose of and while actually engaged in loading or unloading merchandise or passengers.

Parking Area: An area used by the public as a means of access to, and egress from, and for the free parking of motor vehicles by patrons of a shopping center, business, factory, hospital, institution, or similar building or location.

Parking pawl: A device fitted to a motor vehicle's automatic transmission designed to engage when the transmission shift lever selector is placed in the PARK position. The parking pawl locks the transmission's output shaft, stopping the shaft (and thus the driven wheels) from rotating.

Part B: Refers to the section of IDEA (20 USC 1400 *et. seq.*) applicable to special education and related services for children with disabilities and to the implementing regulations at 34 CFR 300.

Part HC: Refers to the section of the IDEA related to early intervention services for infants and toddlers and to the implementing regulations at 34 CFR 303. Formerly referred to as Part H.

Particulates: Small solid particles (soot, etc.) formed by engine combustion. Visible particulates are seen in smoke; however, invisible particles may be present in smokeless exhaust.

Particulate trap: An exhaust treatment device used to collect (trap) and periodically burn off particulates and other potential problem emission gases formed in engine exhaust. (See also *DPF*.)

Passenger: A person who rides in a school bus but does not operate it. (See also *Occupant*.)

Passenger compartment: Space within the school bus interior measured from a point 30 inches ahead of the forward most passenger seating reference point (SRP) rearward to the inside surface of the rear end of the bus at the center of the rear emergency exit.

Passenger endorsement: A designation (P) on a CDL that indicates the driver is qualified to drive a commercial passenger vehicle. Must accompany an S endorsement.

Passenger miles: The total number of miles traveled by the aggregate number of passengers on a vehicle. (Example: Two students traveling four miles would equal 8 passenger miles, and five students traveling three miles would equal 15 passenger miles—totaling 23 passenger miles.)

Pedestrian: Any person afoot.

Performance base procurement: Competitive procedure in which contracts are awarded based on a combination of price and past performance; also known as *Best Value Procurement*.

Pilot ignition engine: An engine using a small quantity of diesel fuel to provide an ignition source for an alternative fuel that will not ignite on its own in a compression cycle.

P.L. 94-142 (See *EHA*.)

Port injection: Similar to the throttle body system except that the fuel is injected near each cylinder intake port. The injectors and their controls can be individually controlled for maximum performance and emissions control.

Positive-locking: A design feature of the mobility aid securement and occupant restraint system where the attachment and anchoring hardware cannot be inadvertently released or disengaged once properly installed.

Post-trip interior inspection: A check of the interior of the bus by the driver at the end of the run to ensure that no children or student belongings have been left behind.

Postural support: A seat, belt or other component used to support a child with disabilities in a desired position but not designed or intended to provide occupant restraint in a crash; also known as positioning device.

Power base: A powered, wheeled platform used to mount a seating device for carrying an individual with a disability; usually characterized by smaller diameter tires.

Power cut-off switch: A device that cancels all power from the vehicle batteries.

Power lift: A mechanized platform designed to provide access to a vehicle for an occupied mobility aid/wheelchair; also known as a *wheelchair lift*.

Powertrain: The group of components used to transmit engine power to the wheels; includes engine, transmission, universal joints, driveshaft, drive axles and gears; also known as *drivetrain*.

Pphm: Parts per hundred million

Pre-school: Refers to a child between the ages of three and five years who is not yet in kindergarten or to a program serving children in that age range.

Pre-trip inspection: A systematic inspection of the bus by the driver before every trip or shift to ensure that the bus is in safe operating condition. The same procedure performed after the trip/shift is the *post-trip inspection*.

Preventable accident: Any incident in which a school bus driver failed to do everything reasonable to prevent the accident.

Private Road or Driveway: Every way or place in private ownership and used for vehicular travel by the owner and those having express or implied permission from the owner, but not by other persons.

Privatization: The process of transferring the operation of public services from the public agencies to private companies or nonprofit organizations; also known as *contracting* or *outsourcing*.

Pupil (See *Student*.)

Pusher: A school bus in which the engine is mounted in the rear of the vehicle; also known as rear-engine bus. (See also *School bus, Type D*.)

Pushout window: A bus window that is hinged at the top or front to enable the window to be swung upward or outward relative to the side of the bus and to provide a means of emergency egress from the bus; also known as *emergency window*.

Railroad crossing (grade crossing): The intersection of a highway, street or roadway and railroad tracks.

Railroad Sign or Signal: Any sign, signal, or device erected by authority of a public body or official or by a railroad and intended to give notice of the presence of railroad tracks or the approach of a railroad train.

Ramp: An inclined plane for use between the ground and the floor of the vehicle to permit access by persons in wheelchairs/mobility aids.

Reflective: Refers to the property of materials that cause them, when they are illuminated, to reflect the light to some extent.

Reformulated gasoline: Also known as “oxygenated gasoline,” reformulated gasoline has oxygen added to improve combustion and reduce emissions.

Related services: Transportation and other supportive services that are required to assist a child with a disability to benefit from special education.

Remanufactured: Refers to a vehicle component that has been structurally restored.

Repower installation: A dedicated natural gas or other engine which was not part of the original chassis at the time of manufacturing.

Residence District: The territory contiguous to a highway not comprising a business district, when the frontage on such a highway for a distance of three hundred feet or more is mainly occupied by dwellings or by dwellings and buildings in use for business.

RESNA: Rehabilitation Engineering and Assistive Technology Society of North America; an organization engaged in research and development of assistive technology for persons with disabilities.

Restraining barrier: An assembly similar to a seat back located immediately in front of a single school bus passenger seat or row of seats to provide crash protection in accordance with FMVSS No. 222; also known as *barrier*, *crash barrier* and *seat barrier*.

Restraint system: A generic term for one or more devices intended to secure and protect a passenger with or without a mobility aid in a vehicle, including lap belts, lap/shoulder belts, child safety seats, safety vests, etc.

Restraint/securement system (See *Securement and restraint system*.)

Retractor, automatic-locking: A retractor incorporating adjustment by means of a positive self-locking mechanism which is capable of withstanding restraint forces.

Retractor, emergency-locking: A retractor that incorporates adjustment by means of a locking mechanism that is activated by vehicle acceleration, webbing movement relative to the vehicle, or automatic action during an emergency, and that is capable of withstanding restraint forces.

Retroreflective: Refers to material that is designed to direct light back to its source.

Revocation (of driver’s license): The act of termination of a license to drive a motor vehicle on highways.

RFID: Radio Frequency Identification, use of electromagnetic fields to capture and transfer data.

RFP: Request for Proposals; an invitation to submit a contract proposal, less restrictive than an invitation to bid on a contract.

Ridership: The number of passengers using a transportation system during a given time period.

Right: Right position is determined from the normal driving position as seated in the driver’s seat looking in the forward direction of travel.

Right of Way: The privilege of the immediate use of the highway.

Rim: The part of the wheel on which the tire is mounted and supported.

Risk management: Practices and procedures designed to protect against losses from accidents, passenger and worker injuries, vehicle damage and other losses, and to reduce insurance costs.

Roadway: That portion of a highway improved, designed, or ordinarily used for vehicular traffic, exclusive of the berm or shoulder. A divided highway has two or more roadways.

Rolling stock: The vehicles in a transportation system.

Roof hatch (See *emergency roof exit*.)

Route: The combined total daily trips (or runs) regularly traveled by a school bus to pick up students and take them to school, or to deliver students from school to their homes or designated bus stops.

Route miles: The total number of miles in one or more routes in the system.

Route (trip) sheet: A list of all the designated stops on a route.

Run: A complete trip on a route. [To illustrate the difference between a run and a route, it is possible to have six daily runs on the same route (i.e., one high school, one middle school, and one elementary run both morning and afternoon).]

Running gear: The wheels, axles, springs, frames and other carrying parts of the vehicle.

SAE: Society of Automotive Engineers; the leading standards-writing organization for the automotive industry.

Safe riding practices classroom instruction form (Form T-7): The Louisiana Department of Education form used to verify that all students in a school have received instruction on safe school bus riding practices. Forms must be signed by every public school principal and must be filed with the Transportation Department once every semester. (See sample Form T-8 in Bulletin 119, Supplement II, Appendix B.)

Safety incident: An occurrence that represents a close call/near miss or recognized heightened level of risk to students traveling to and from school or school-related activities.

Safe travel training: Educational programs provided for students to teach safe procedures for travel to and from school and home and to and from school-related activities.

Safety patrol: Students whose duties may include acting as crossing guards and safety assistants.

Safety ridership training: Educational programs provided for students to teach proper behavior while waiting for, riding in, boarding or leaving school buses; also known as *ridership programs*. (See *Safe riding practices classroom instruction form*.)

Safety vest (harness): A combination pelvic and upper torso child restraint system that consists primarily of flexible material, such as straps, webbing or similar material, and that does not include a rigid seating structure for the child. Must be used with a cam wrap on a school bus seat.

Safety Zone: The area or space which is officially set apart within a highway for the exclusive use of pedestrians and which is protected or is so marked or indicated by adequate signs as to be plainly visible at all times while set apart as a safety zone.

SAP: Substance Abuse Professional; a licensed physician, psychologist, social worker or alcohol and drug counselor who is required to evaluate any employee who violates a carrier's drug and alcohol testing program.

SBMTC: School Bus Manufacturers Technical Council; formerly the School Bus Manufacturers Institute (SBMI); a membership organization within NASDPTS which serves as a technical advisor regarding school bus technology and construction.

School: An educational institution for children at the pre-primary, primary, elementary, or secondary level, including nursery schools and Head Start programs, but not including day care programs.

School bus: (See *Bus, school bus*.)

School bus behavior report form (SB): The Louisiana Department of Education form that is required to inform parents/guardians of behavioral incidents on the school bus and subsequent disciplinary action taken by school officials. The form requires the signature of the principal (or designated authority) and allows for comment from the student and/or parent/guardian. (See example in Bulletin 119 Supplement Vol. II, Appendix B.)

School bus driver: (See *Operator, school bus*, for Louisiana definition.)

School bus equipment: Equipment designed primarily as a system, part or component of a school bus, or any similar part or component manufactured or sold for replacement or as an accessory or addition to a school bus.

School bus operator: The term school bus operator, as used in (R.S. 17:150), shall mean any individual who operates a school bus (for the purpose of) transporting children under the supervision of the public school system of the state of Louisiana. (***Note:** The Louisiana Legislature, in 2017, revised statutes that referred to school bus drivers to school bus operators, thus making the terms synonymous.)

School bus operator certification program: The school bus operator certification program developed by the Louisiana Department of Education and mandated by state law for all school bus operators to be eligible to transport students to and from public schools or school-related activities.

School bus purchase form (Form T-10): The form to be completed by the seller, the purchaser and the LEA for any new or used school bus to certify that the vehicle meets all Federal Motor Vehicles Safety Standards (FMVSS) and requirements set forth by the Louisiana Legislature and the Board of Elementary and Secondary Education. (See Example of Form T-10 in Appendix D.)

School bus stop: An area along the street or highway designated by school officials for picking up and discharging students.

School bus traffic warning lamps: (See *Alternately flashing signal lamps*.)

School bus endorsement: A designation (S) on a CDL that indicates the driver is licensed to operate a school bus.

School trip (See *Activity trip*.)

School vehicle: Any vehicle owned, leased, contracted to or operated by a school or school district and regularly used to transport students to and from school or school-related activities. Includes school buses, activity buses, vans and passenger cars, but does not include transit or charter buses.

SCR: Selective catalyst reduction; A type of NO_x reducing technology which uses a chemical reductant (diesel exhaust fluid, or DEF) injected into the exhaust stream where it transforms into ammonia and reacts with NO_x on a catalyst, converting the NO_x to nitrogen gas and water vapor. The reducing agent needs to be periodically replenished.

Scooter: A motorized mobility aid with three wheels, handle bar or tiller and a swiveling seat. SEA: State Education Agency.

Seat: A device designed and installed to provide seating accommodations.

Activity seat: A seat designed for passenger comfort with contoured seats and backs with the result that passengers' positions are distinctly separate; characterized by fixed seat backs; may have arm rests and head rests; can be manufactured to meet FMVSS No. 222.

Bench seat: A seat designed to accommodate more than one passenger with no apparent partitioning between positions, which is characterized by fixed legs and a fixed back (e.g., the standard school bus seat which meets FMVSS No. 222).

Davenport seat: A bench seat that extends from side wall to side wall at the rearmost seating position in the bus; not permitted in school buses.

Flex seat: A type of bench seat equipped with lap/shoulder seat belts that can be reconfigured so that the number of seating positions on the seat can change. An example is a seat that can be reconfigured to accommodate either three smaller students or two larger students; also known as *flexible seating systems* or *flexible occupancy seats*.

Flip seat: A school bus bench seat designed so that the cushion flips up when the seat is not occupied, similar to a theater seat; used to provide aisle clearance, as required by FMVSS No. 217, when a passenger seat is located adjacent to a side emergency door.

Integrated child safety seat: A child safety seat meeting the requirements of FMVSS No. 213 which is built into, and thus an integral part of, a bench seat.

Jump seat: A seat designed to fold down to provide supplemental seating in a bus (e.g., in the aisle, in front of the door or along the side wall); not permitted in school buses.

Reclining seat: An activity seat with a reclining seat back; not permitted in school buses.

Seat belt ready seat: A bench seat meeting the requirements of FMVSS No. 222, the frame of which is designed for the installation of lap belts or CSRS attachment devices under FMVSS 210.

Seat belt: A passenger restraint system incorporating lap belts or lap/shoulder belts and meeting the requirements of FMVSS Nos. 209 and 210.

Seating capacity: The number of designated seating positions provided in a vehicle, including the driver's position. In determining vehicle classification, each wheelchair securement location shall be counted as four (4) designated seating positions.

Equipped (or rated) seating capacity: The number of designated seating positions provided in a bus per the manufacturer's body/seating plan.

In-use seating capacity: The number of passengers who can physically sit fully upon the assigned seats in a school bus, with

Reduced capacity: The capacity that is achieved when one or more seats are removed from the standard design during or after manufacture of the vehicle. (Example, seats removed to accommodate wheelchairs.)

Seating position: The space on a school bus bench seat designated for one student. The number of such positions per seat is determined by dividing the width of the seat by 15" and rounding to the nearest whole number, as described in FMVSS No. 222.

Seating reference point: The manufacturer's design point, with coordinates relative to the vehicle structure, which establishes the rearmost normal driving or riding position of each designated seating position and simulates the position of the pivot center of the human torso and thigh.

Section 402: Section of 23 CFR that authorizes grant funds for highway safety projects.

Section 504: Section of the Rehabilitation Act of 1973, PL 93-112, which prohibits discrimination against individuals with disabilities by any recipient of federal funding.

Securement points: Locations on the base or seat frame of the wheelchair/mobility aid where the securement system should be attached.

Securement system: The means of securing a mobile seating device to a vehicle in accordance with FMVSS No. 222, including all necessary buckles, anchors, webbing/straps and other fasteners.

Securement and restraint system: The total system which secures and restrains both a wheelchair/mobility aid and its occupant; also known as WTORS.

Self-insured: Refers to a company or school district which provides reserved funds against claims or losses.

Sensor: An electronic device installed on a school bus for the purpose of detecting animate objects in the loading zone; also known as *object detection system*.

Seizure: A reaction to an electrical discharge in the brain, resulting in symptoms which can range from a blank stare of a few seconds to full convulsions.

Shoulder: The portion of the highway contiguous with the roadway for accommodation of stopped vehicles, for emergency use, for loading and unloading school bus passengers* and for lateral support of base and surface. (*See R.S. 17:158.J.)

Shuttle: A trip run back and forth over a short route (e.g., between two schools).

Sidewalk: That portion of a highway between the curb lines, or the lateral lines of a highway, and the adjacent property lines, intended for the use of pedestrians.

Skid plate: Stout metal plate attached to the underside of a vehicle to protect the oil pan, transmission, step well or fuel tank from scraping on rocks, curbs and road surface.

Slack adjuster: Adjustable device connected to the brake chamber pushrod that transmits brake application force and compensates for lining wear.

SOS lights: Stop on signal lights. (See also *Alternately flashing signal lamps*.)

Special education: Specially designed instruction to meet the unique needs of a child with disabilities.

Special Route (trip): A route (trip) established for students with special needs, such as:

- A. Students whose educational opportunities are offered at locations out of their regular school attendance district (e.g., ESOL, alternative school, special education);
- B. Students with disabilities who cannot be transported by a conventional (aka “regular”) school bus, who require a bus attendant (bus aide) for assistance or who must be transported in non-school buses that meet appropriate federal, state and special equipment requirements.

Specially equipped school bus: Any school bus designed, equipped or modified to accommodate students with special needs.

Split-brake system: A service brake system with two separate hydraulic circuits which, upon failure of either, retains full or partial braking ability.

Stanchion: An upright post or bar, usually installed from floor to ceiling in a bus, that provides support for other structural members and/or provides a hand-hold for passengers.

State: As used in this document, “state” shall refer to any of the 50 states and commonwealths and any United States territory, possession, or federal agency (e.g., the General Services Administration or the Department of Defense) that may consider, follow or adopt part or all of the specifications and

procedures contained herein for school buses and operations.

State director: The chief government administrator in charge of a state's student transportation program and responsible for oversight of regulatory functions.

Stoichiometric burn: Use of fuel and air (or oxygen) in the exact ratio needed for complete combustion to generate maximum efficiency and power.

Stop: The complete cessation of movement.

Stop arm (stop semaphore or stop signal arm): A device in the form of a red octagon meeting FMVSS No. 131 and extending outward from the side of a school bus to signal that the bus has stopped to load or unload passengers.

Stopping distance: The sum of perception distance, plus reaction distance, plus lag distance (for vehicles equipped with air brakes), plus braking distance.

Perception distance: The distance a vehicle travels between the time the driver sees a potential hazard and reacts accordingly.

Reaction distance: The distance a vehicle travels during the time it takes for a driver to recognize the need to stop and to apply the brakes.

Brake lag distance (air brakes): The distance a vehicle equipped with air brakes travels before the air, traveling from the air reservoir, reaches and activates the brake wheel cylinders.

Braking distance: The distance a vehicle travels between the time the brakes are applied and the time forward motion ceases.

Street: The entire width between the boundary lines of every way or place of whatever nature publicly maintained and open to the use of the public for the purpose of vehicular travel, including bridges, causeways, tunnels, and ferries; synonymous with the word "highway."

Strobe light: A bright short duration light that flashes as a result of an electronic discharge of electricity through a gas.

Stroller: A light weight folding mobility aid.

Student: Any child who attends a school, as previously defined.

Student and Family Verification Form: A form used to verify that parents/guardians have read and reviewed with their child the rules and regulations for students riding buses. The form requires signatures of the parent/guardian and the student. The completed form is made part of the student's permanent record.

Student rides: The number of students transported in a given system multiplied by the number of one-way trips in a school bus. [For example, a school district that transports 1,000 students provides 2,000 student rides daily or 360,000 student rides to and from school annually, assuming 180 school days. To determine the total number of student rides annually, the district would add the actual or estimated number of students transported on activity trips (times 2) to the figure above.]

Substitute driver: A driver who is not assigned to a regular route but is employed to provide immediate coverage, when necessary, due to driver absences or emergencies; also known as spare driver and extra-board driver.

Surrogate wheelchair: A wheelchair device which is subjected to impact tests to test securement and restraint systems.

Suspension system: The components of the vehicle that transmit the load of the vehicle's weight from

the chassis framework to the ground, including the springs, axles, wheels, tires and related connecting components.

T-7 Form: Louisiana Department of Education safe riding practices classroom instruction form used to verify that all students in a school have received instruction on safe school bus riding practices. The form must be completed at the beginning of each semester and submitted to the transportation provider's transportation office.

T-8 Form: Louisiana Department of Education school bus emergency evacuation drill verification form used to verify that emergency drill procedures have been taught to passengers and that emergency drills were conducted in accordance with Department of Education procedures. The form must be completed at the beginning of each semester and submitted to the transportation provider's transportation office.

T-9 Form: The Louisiana Department of Education school bus driver emergency drill report that documents that emergency evacuation drills were conducted for assigned passengers for every school on each driver's route.

T-10 Form: The Louisiana Department of Education school bus purchase form to be completed by the seller of any new or used school bus to verify that the vehicle meets all Federal Motor Vehicle Safety Standards (FMVSSs), Louisiana statutory requirements and specifications promulgated by the Louisiana Department of Education.

TDD: Telecommunication devices for the deaf.

Temperature control system: The means of heating or cooling the interior of the vehicle.

Tenured School Bus Operator: A full-time operator who successfully completed the three-year probationary period prior to July 1, 2012. (See R.S. 17:492.)

Tether: An upper anchor strap used in addition to a seat belt to hold certain types of restraint devices in place.

Throttle body injection: A gasoline fuel injection system in which the fuel is injected directly into the air intake pipe or manifold. No carburetor is required; electronics monitor engine variables and control the rate of fuel injected.

Tie down system (See *Securement system*.)

Tier: Any level of separate runs and routes designed to allow a single bus to complete multiple routing assignments. Multiple assignments typically require the use of staggered school schedules, permitting multiple levels or "tiers" for the daily assignment(s).

Tire: The continuous solid or pneumatic rubber elastomeric cushion encircling a wheel intended for contact with the road.

Bias ply: A pneumatic tire in which the ply cords extending to the beads are laid at alternate angles substantially less than 90 degrees to the centerline of the tire.

Low profile: A tire that has a section height that is less than 85 percent of its nominal section width (e.g., a tire with an aspect ratio of less than 0.85).

Radial: A pneumatic tire in which the ply cords which extend to the beads are laid substantially at 90 degrees to the centerline of the tread.

Retread: A worn tire casing to which tread rubber has been affixed to extend the usable life of the tire; also known as *re-capped* or *retreaded tire*.

Siped: A tire which has been scored or cut perpendicular to the direction of rotation (across the tread) to improve traction.

Snow: A tire with an obvious aggressive or lug-type tread across the entire width that is designed to be self-cleaning.

Studded: A tire to which metal protrusions have been added to improve traction.

Tire cords: The strands forming the reinforcement structure in a tire.

To-and-from school: Transportation from home to school and from school to home; also transportation from school to school or from school to job training site.

Tour: Transportation of a group on a longer trip, usually by *charter bus* (e.g., senior class trip to Washington).

Tow devices: Attachments on the chassis frame for use in retrieving a stuck vehicle and/or for towing the vehicle backwards or forwards; also known as *tow eyes*, *tow hooks* or *towing attachment points*.

Track seating: A seating system in which seating units, including mobility aids, are secured to the vehicle structure by attaching them to tracks on the vehicle floor.

Traffic: Pedestrians, ridden or herded animals, vehicles and other conveyances either single or together while using any highway for purposes of travel.

Traffic control device: All signs, signals, markings and devices placed or erected by authority of a public body or official having jurisdiction for the purpose of regulating, warning or guiding traffic.

Traffic control signal: A type of highway traffic signal, manually, electrically or mechanically operated, by which traffic is alternately directed to stop and permitted to proceed.

Traffic lights: Illuminated traffic signals which control the flow of traffic at intersections.

Transportation Vehicle: LEA-owned school buses, independently owned school buses or other approved vehicles used for transporting passengers to and from school and school-related activities.

Transverse: Perpendicular to the longitudinal centerline of the vehicle (i.e., from side to side).

Trip: The transportation of students from home to school or from school to any destination, followed by a return trip back to school or from school to home. The two together individual trips constitute a *round trip*.

Tripper service: Regularly scheduled mass transit service which is open to the public, and which is designed or modified to accommodate the needs of school students and personnel, using various fare collections or subsidy systems. Must be part of the regular route service as indicated in published route schedules.

TSA: Transportation Security Administration; an agency of the Department of Homeland Security.

Turbocharger: a device which uses the pressure of exhaust gases to drive a turbine that, in turn, pressurizes air normally drawn into the engine's chambers.

Turnkey: Partial privatization in which a school district hires a company to supply drivers, maintenance management and/or vehicles; also known as *management contract*.

Two-way radio: Electronic communication system which uses a designated airway for transmission between a bus and a base station.

UL: Underwriters Laboratory.

ULSD: Ultra-low sulfur diesel; Diesel fuel that has a sulfur content of not more than 15 ppm (parts per million). Regular diesel fuel has a sulfur content of 200 ppm.

UMTA: Urban Mass Transit Administration; predecessor to FTA.

Unload: To discharge passengers from a school bus.

Unloaded vehicle weight: The weight of a vehicle with maximum capacity of all fluids necessary for operation, but without cargo or occupants or accessories that are ordinarily removed from the vehicle when they are not in use.

Universal precautions: Method of infection control designed to protect the individual from exposure to disease, which requires that all bodily fluids and secretions are treated as though they were infectious.

UST: Underground storage tank.

Vapor lock: Boiling or vaporization of fuel in the lines from excessive heat, which interferes with liquid fuel movement and in some cases stops the flow.

Vehicle miles: The aggregate number of miles a vehicle travels in a given period.

Video system: A means of monitoring student behavior in a school bus. The system includes one or more video cameras to tape activity. Camera housing units mounted in each bus appear to hold a camera, whether or not one is actually in place; also known as *surveillance*.

VIN: Vehicle Identification Number; a series of Arabic numbers and Roman letters which is assigned to a motor vehicle for identification purposes.

Viscosity: A measure of internal resistance to flow or motion offered by a fluid lubricant.

Walking distance: The distance a student is required to travel to or from a bus stop; also, the maximum distance a student can be required to walk to school without mandatory transportation being provided; also known as *non-transportation zone*.

Weather emergencies: Weather conditions that require a deviation from normal transportation procedures (e.g., flooding, snowstorm).

WC-19: A voluntary industry standard that establishes minimum design and performance requirements for wheelchairs that are occupied by users traveling in motor vehicles. The standard applies to a wide range of wheelchair types and styles, including manual wheelchairs, powerbase wheelchairs, three wheeled scooters, tilt-in-place wheelchairs and specialized mobile seating bases with removable seating inserts.

Weight distribution: The distribution proportion of the vehicle load divided between the front and rear axles.

Wheel: A rotating load-carrying member between the tire and the hub, usually consisting of two major parts—the rim and the wheel disc—which may be integral, permanently attached or detachable.

Ball seat nut mounting: A wheel mounting system wherein the wheel centering is provided by the wheel mounting studs and the ball seat nuts which, when properly tightened, assure the centering alignment of the wheel.

Disc: The part of the wheel which is the supporting member between the hub and the rim.

Disc wheel: A permanent combination of a rim and wheel disc.

Hub: The rotating outer member of the axle assembly which provides for wheel disc mounting

Locking ring: A removable, split rim ring that holds the rim flange in place on a multi-piece rim.

Piloted hub mounting: A wheel mounting system wherein the wheel centering is provided by a close fit between the wheel disc and the hub.

Rim: The part of the wheel on which the tire is mounted and supported.

Spoke wheel: A rotating member which provides for mounting and support of one or two demountable rims; also known as *wheel for demountable rim*.

Wheelbase: The distance between the centerline of the front axle and the centerline of the rear axle.

Wheelchair: A seating system comprised of at least a frame, a seat and wheels that is designed to provide support and mobility for a person with physical disabilities. For the purpose of this standard, this term encompasses standard manual wheelchairs, powered wheelchairs, power-based wheelchairs, three-wheel scooter-type wheelchairs and specialized seating bases; also known as *mobile seating device*.

Wheelchair lift (See *Power lift*.)

ZEB: Zero-emissions bus.

ZEV: Zero-emissions vehicle.

APPENDIX B: Supplements to School Bus Body and Chassis Specifications

NATIONAL SCHOOL BUS YELLOW STANDARD

The color known as National School Bus Yellow (NSBY) is specified below.

S1: SCOPE

School Bus Manufacturer’s Technical Council (SBMTC)

National School Bus Yellow Color Standard SBMTC-008 (Source Document)

This standard defines the color for a newly manufactured school bus having “National School Bus Yellow” by fundamental colorimetric data.

S2: PURPOSE

This standard is intended for use by manufacturers of school bus type vehicle body and chassis for purposes of procurement, and inspection.

S3: APPLICATION

This standard applies to school buses.

S4: COLOR DEFINITION

The color “National School Bus Yellow” is defined as: The color resulting from the colorimetric tri-stimulus data shown on the following page.

COLORIMETRIC (CIE) DATA, C/10°

DESCRIPTION	REFLECTANCE	CHROMATICITY	
	Y	x	y
Centriod	40.2%	.4882	.4205
Light Limit	41.8%	.4882	.4198
Dark Limit	38.5%	.4902	.4206
Green Limit	40.6%	.4844	.4217
Red Limit	40.3%	.4907	.4174
Yellow Limit	40.6%	.4901	.4225
Blue Limit	40.2%	.4828	.4162

S5: REQUIREMENTS

The color “National School Bus Yellow” shall conform to the tolerance limits set in S4.

S6: COLOR MATCHING

The colorimetric data should be used for acceptance testing purposes. However, accurate comparison can be made only if values are obtained on the same instrument standardized under the same conditions.

Because this standard is not intended to be a performance standard for the paint and/or materials used in the manufacture of the school buses, color matching procedures provided in this standard cannot be used to determine conformity with this standard of school bus type vehicles in use.

BUS BODY HEATING SYSTEM TEST

A. Scope

This procedure, limited to liquid coolant systems, establishes uniform cold weather bus vehicle heating system test procedures for all vehicles designed to transport ten (10) or more passengers. Required test equipment, facilities and definitions are included. Defrosting and defogging procedures and requirements are established by SAE J381, *Windshield Defrosting Systems Test Procedure and Performance Requirements—Trucks, Buses, and Multipurpose Vehicles*, and SAE J382, *Windshield Defrosting Systems Performance Guidelines—Trucks, Buses, and Multi-Purpose Vehicles*, which are hereby included by reference.

Purpose: This procedure is designed to provide bus manufacturers with a cost-effective, standardized test method to provide relative approximations of cold weather interior temperatures.

B. Definitions

1. **Heat Exchanger System:** Means will exist for providing heating and windshield defrosting and defogging capability in a bus. The system shall consist of an integral assembly or assemblies, having a core assembly or assemblies, blower(s), fan(s) and necessary duct systems and controls to provide heating, defrosting and defogging functions. If the bus body structure makes up some portion of the duct system, this structure or a simulation of this structure must be included as part of the system.
2. **Heat Exchanger Core Assembly:** The core shall consist of a liquid-to-air heat transfer surface(s), liquid inlet and discharge tubes or pipes.
3. **Heat Exchanger-Defroster Blower:** An air moving device(s) compatible with energies available on the bus body.
4. **Coolant:** A 50-50 solution of commercially available glycol antifreeze and commercial purity water. Commercial purity water is defined as “that water obtained from a municipal water supply system.”
5. **Heat Exchanger-Defroster Duct System:** Passages that conduct inlet and discharge air throughout the heater system. The discharge outlet louvers shall be included as part of the system.
6. **Heater Test Vehicle:** The completed bus as designed by the manufacturer with or without a chassis, engine and driver train, including the defined heat exchanger system. If the vehicle is without a chassis, it shall be placed on the test site in such a way that the finished floor of the body is at a height, from the test site floor, equal to its installed height when on a chassis, and all holes and other openings normally filled when installed on a chassis will be plugged.
7. **Heat Transfer:** The transfer of heat from liquid to air is directly proportional to the difference between the temperatures of the liquid and air entering the transfer system, for a given rate of liquid and air flow measured in pounds per minute, and that heat removed from liquid is equal to heat given to air.

C. Equipment

1. **Test Site:** A suitable location capable of maintaining an average ambient temperature not to exceed 25°F (-3.9°C) for the duration of the test period. The maximum air velocity across the vehicle shall be 5 mph (8 kph).
2. **Coolant Supply:** A closed loop system, independent of any engine/drive train system, capable of delivering a 50-50 (by volume) solution of antifreeze-water, as defined in 2.4, at 150°±5° (65.5°±1.7°C) above the test site ambient temperature, and 50 lbs (22.7 kg) per minute flow. The coolant supply device shall be equipped with an outlet diverter valve to circulate coolant within the device during its warm-up period. The valve will then permit switching the coolant supply to the bus heat exchanger system at the start of the test.

3. **Power Equipment Supply:** A source capable of providing the required test voltage and current for the heater system.
4. **Heat Exchange Units:** The heat exchangers used shall be labeled as specified by the School Bus Manufacturers Technical Council Standard No. 001, *Procedure for Testing and Rating Automotive Bus Hot Water and Heating and Ventilating Equipment* (Revised 4/94). The test rating of each unit, and quantity used, shall be recorded.

D. Instrumentation

1. Air Temperature

- a. **Interior:** Recommended air temperature measuring instrumentation are thermocouples or resistance temperature detectors (RTDs). Thermometers are not recommended because of their slow response to rapid temperature changes. Measuring instrumentation shall be placed on alternate seat rows beginning 39±5 inches (99±13 cm) from the rear of the body, at 36±2 inches (91±5 cm) from the finished floor of the body, and on the longitudinal centerline of the body.
- b. **Ambient:** A set of four electrically averaged temperature measuring devices shall be placed 18±5 inches (46±13 cm) from the nearest body surface, 96±5 inches (243±13 cm) above the floor of test site. One measuring device shall be placed at each of the following locations:
 - I. Midline of body forward of windshield;
 - II. Midline of body aft of the rear surface; and
 - III. Midway between the axles on the right and left sides of the body.
- c. **Driver:** Measuring devices shall be placed at appropriate locations to measure ankle, knee, and breath level temperatures with the driver's seat in rearmost, lowest and body centermost position.
 - I. **Ankle Level:** Place a minimum of four electrically averaged temperature measuring devices at the corners of a 10 x 10 inches (25x25cm) square area, the rearmost edge of which begins 8 inches (20 cm) forward of the front edge of, and centered on, the seat cushion. The devices shall be located 3±0.5 inches (7.5±1.3 cm) above floor surface.
 - II. **Knee Level:** Place a minimum of one measuring device at the height of the front top edge of the seat cushion and on the centerline of the seat. This measurement shall be 4±1 inches (10±2.5 cm) forward of the extreme front edge of the seat cushion and parallel to the floor.
 - III. **Breath Level:** Place a minimum of one measuring device 42±2 inches (107±5 cm) above the floor and 10±2 inches (25±5 cm) forward of the seat back. The forward dimension shall be measured from the upper edge of the seat back and parallel to the floor.
- d. **(Optional) Heat Exchanger Inlet and Outlet Temperature:** A minimum of four electrically averaged temperature measuring devices shall be used to measure the inlet air temperature of each heat exchange unit. Additionally, a minimum of four electronically averaged temperature measuring devices shall be used to measure the outlet air temperature of each heat exchange unit. These sensors shall be placed no closer than 2.0 inches (5.1 cm) from the face of any heater core, to prevent any incidence of radiant heat transfer. Outlet sensors shall be distributed throughout the outlet air stream(s) 1.0±0.25 inches (2.5±0.6 cm) from the outlet aperture(s) of the unit heater.
- e. **(Optional) Defrost Air Temperature:** The temperature of the defrost air shall be measured at a point in the defroster outlet(s) that is in the main air flow and which is at least 1.0 inch (2.54 cm) below (upstream of) the plane of the defroster outlet opening. At least

one temperature measurement shall be made in each outlet unit. The interior surface temperature(s) of the windshield shall be measured at a point located on the vertical and horizontal centerline(s) of the windshield.

- f. **(Optional) Entrance Area Temperature:** The temperature of the vehicle entrance area shall be measured by two sets of three each electrically averaged temperature measuring devices. One set of three devices shall be placed 1.0 inch (2.54 cm) above the lowest tread of the entrance step, equally spaced on the longitudinal centerline of the tread. The second set of devices shall be placed on the next horizontal surface above the lowest entrance step, 4.0 inches (10.2 cm) from the outboard edge of that surface, spaced identically to the first set of sensors, and placed parallel with the outboard edge of the surface being measured.
2. **Coolant Temperature:** The temperature entering and leaving the heat exchanger/defroster system shall be measured as close to the entrance and exit points of the bus body as possible with an immersion thermocouple or RTD device which can be read within $\pm 0.5^{\circ}\text{F}$ ($\pm 0.3^{\circ}\text{C}$).
3. **Coolant Flow:** The quantity of coolant flowing shall be measured by means of a calibrated flow meter or weighing tank to an accuracy of at least 2% of setpoint.
4. **Coolant Pressure:** The coolant differential pressure shall be measured by suitable connection as close as possible to the inlet and outlet of the heat exchanger/defrosting system. Pressure may be read as inlet and outlet pressure and the differential calculated, or read directly as PSID. Pressure readings shall be made with the use of gauges, manometers or transducers capable of reading within ± 0.1 psi (689.5 Pa), accurate to $\pm 0.5\%$ of full scale.
5. **Additional Instrumentation:** Additional instrumentation required for vehicle heat exchanger system testing is a voltmeter and a shunt-type ammeter to read the voltage and current of the complete system. The ammeter and voltmeter shall be capable of an accuracy of $\pm 1\%$ of the reading.

E. Test Procedures

1. Install the heater test vehicle on the test site. Testing shall be conducted in such a way as to prevent the effects of solar heating. At an outdoor test site, testing shall commence and data shall be recorded during the hours following sunset and prior to sunrise, regardless of cloud cover or facility roof. Instrumentation is required to obtain the following readings:
 - a. Vehicle interior (4.1.1);
 - b. Inlet coolant temperature, at entrance to the bus body (4.2);
 - c. Discharge coolant temperature, at exit from the bus body (4.2);
 - d. Voltage and current at main bus bar connection of driver's control panel;
 - e. Ambient temperature (4.1.2);
 - f. Rate of coolant flow (4.3);
 - g. Coolant flow pressure (4.4);
 - h. Elapsed time (stop watch);
 - i. Driver's station temperatures (4.1.3);
 - j. (Optional) Heat Exchanger Inlet and Outlet Temperatures (4.1.4);
 - k. (Optional) Defrost Air Temperature (4.1.5); and
 - l. (Optional) Entrance Area Temperature (4.1.6).
2. Soak the test vehicle, with doors open, for the length of time necessary to stabilize the interior

temperature for a 30-minute period as recorded by the vehicle interior temperature measuring devices, and the coolant temperature as measured by the inlet and outlet coolant temperature measuring devices, at the test site temperature, $\pm 5^{\circ}\text{F}$ ($\pm 2.5^{\circ}\text{C}$), not to exceed 25°F (-3.9°C). Warm up the coolant device to the test temperature immediately prior to the start of the test. Use the coolant supply outlet diverter valve to prevent heated coolant from entering the bus heating system prior to the start of the test.

3. At this time, set the heater controls and all fan controls at maximum, and close all doors. A maximum of two windows may be left open a total of 1.0 inch (2.5 cm) each. A maximum of two occupants may be in the body during the test period. Record all instrumentation readings at five-minute intervals for a period of 1 hour. Recording time shall begin with the initial introduction of heated coolant from the independent coolant supply. The electrical system shall be operated at a maximum of 115% of nominal system voltage ± 0.2 volts, for example: 13.8 VDC ± 0.2 volts for a 12 volt (DC) system, and the heat exchanger system shall be wired with the normal vehicle wiring.
4. *Optional:* Additional flow rates and/or coolant temperatures may also be used to generate supplementary data. Procedure shall be repeated (see 5. Test Procedure) for each additional flow rate and/or coolant temperature.

F. Computations

1. **Chart and Computations:** Customary Units - Data shall be recorded on Chart 6.1, or equivalent. Temperature data shall be recorded at the actual temperatures occurring at the time of testing. Air temperature data shall then be adjusted to a 0°F base prior to the construction of graphs. This data reduction shall be directly proportional to the difference between the actual ambient temperature, at the time of test, and 0°F (i.e., actual ambient of 18°F shall result in a reduction of all air temperatures by 18°F and actual ambient temperature of -8°F shall result in an increase of all air temperatures by 8°F). Temperature data shall be presented in graph form as well as tabular form. One graph shall be constructed for the body interior air temperatures (4.1.1) wherein the recording intervals shall be the X-axis and the $^{\circ}\text{F}$ the Y-axis. A separate graph shall be constructed for the driver's temperatures (4.1.3) using the same units for the axes. Optional temperature data (4.1.4, 4.1.5, 4.1.6) may be similarly graphed separate from the interior data.

a. Optional Computations BTU/Hr. Coolant

Heat Transfer: $Q_w = C_p W_w (T_{in} - T_{out}) \times 60$ where:

- I. W_w = Flow of Coolant (lb/min) – *measured to ± 2 percent*
 - II. T_{in} = Temperature of Coolant into System ($^{\circ}\text{F}$) – *measured quantity*
 - III. T_{out} = Temperature of Coolant out of System ($^{\circ}\text{F}$) – *measured quantity*
 - IV. Q_w = Heat removed From Coolant (Btu/hr) – *calculated quantity*
 - V. C_p = Specific Heat of Coolant = 0.8515 (BTU/lb/ $^{\circ}\text{F}$) – *given quantity*
2. **Chart and Computations:** Metric Units - Data shall be recorded on Chart 6.2, or equivalent. Temperature data shall be recorded at the actual temperatures occurring at the time of testing. Air temperature data shall then be adjusted to a -18°C base prior to the construction of graphs. This data reduction shall be directly proportional to the difference between the actual ambient temperature, at the time of test, and -18°C (i.e., actual ambient of -7.8°C shall result in a reduction of all air temperatures by 10.2°C and actual ambient temperature of -22.2°C shall result in an increase of all air temperatures by 4.2°C). Temperature data shall be presented in graph form as well as tabular form. One graph shall be constructed for the body interior air temperatures (4.1.1) wherein the recording intervals shall be the X-axis and $^{\circ}\text{C}$ the Y-axis. A separate graph shall be constructed for the driver's temperatures (4.1.3) using the same units for

the axes. Optional temperature data (4.1.4, 4.1.5, 4.1.6) may be similarly graphed separate from the interior data.

a. Optional Computations BTU/Hr – Coolant

Heat Transfer: $Q_w = C_p W_w (T_{in} - T_{out}) \times 60$ where:

- I. W_w = Flow of Coolant (kg/min) – *measured to ± 2 percent*
- II. T_{in} = Temperature of Coolant into System ($^{\circ}\text{C}$) – *measured quantity*
- III. T_{out} = Temperature of Coolant out of System ($^{\circ}\text{C}$) – *measured quantity*
- IV. Q_w = Heat removed From Coolant (Joules/hr) – *calculated quantity*
- V. C_p = Specific Heat of Coolant = 3559 (joule/kg/ $^{\circ}\text{C}$) – *given quantity*

Computational Chart 6.1 (Fahrenheit)

Description of Unit: _____

Purpose of Test: _____

Date:	Location:	Observers:
--------------	------------------	-------------------

Readings/ Calculations Water	0	5	10	15	20	25	30	35	40	45	50	55	60
Flow - lb/min													
Flow Pressure - PSID													
T-in °F													
T-out °F													
Air Temperature													
T1 rear - °F													
T2 - °F													
T3 - °F													
T4 - °F													
T5 - °F													
T6 front - °F													
T7 ambient - °F													
T8 Driver Ankle - °F													
T9 Driver Knee - °F													
T10 Driver Breath - °F													
Electrical System													
Volts													

Computational Chart 6.1 Optional Measurements (Fahrenheit)

Date:	Location:	Observers:
--------------	------------------	-------------------

Readings/Calculations	0	5	10	15	20	25	30	35	40	45	50	55	60
T11 Windshield CL Left °F													
T12 Windshield CL Right °F													
T13 Defrost Outlet Left °F													
T14 Defrost Outlet Right °F													
T15 Heater-Inlet °F													
T15 Heater-Outlet °F													
T16 Heater-Inlet °F													
T16 Heater-Outlet °F													
T17 Heater-Inlet °F													
T17 Heater-Outlet °F													
T18 Heater-Inlet °F													
T18 Heater-Outlet °F													
T19 - 1st Entrance Step													
T20 - 2nd Entrance Step													
Heat Transfer - BTU/Hr-coolant													

Computational Chart 6.2 (Celsius)

Description of Unit: _____

Purpose of Test: _____

Date:	Location:	Observers:
--------------	------------------	-------------------

Readings/ Calculations Water	0	5	10	15	20	25	30	35	40	45	50	55	60
Flow - kg/min													
Flow Pressure - PaD													
T-in °C													
T-out °C													
Air Temperature													
T1 rear - °C													
T2 - °C													
T3 - °C													
T4 - °C													
T5 - °C													
T6 front - °C													
T7 ambient - °C													
T8 Driver Ankle - °C													
T9 Driver Knee - °C													
T10 Driver Breath - °C													
Electrical System													
Volts													

Chart 6.2 Optional Measurements (Celcius)

Date:	Location:	Observers:
--------------	------------------	-------------------

Readings/Calculations	0	5	10	15	20	25	30	35	40	45	50	55	60
T11 Windshield CL Left °C													
T12 Windshield CL Right °C													
T13 Defrost Outlet Left °C													
T14 Defrost Outlet Right °C													
T15 Heater-Inlet °C													
T15 Heater-Outlet °C													
T16 Heater-Inlet °C													
T16 Heater-Outlet °C													
T17 Heater-Inlet °C													
T17 Heater-Outlet °C													
T18 Heater-Inlet °C													
T18 Heater-Outlet °C													
T19 - 1st Entrance Step													
T20 - 2nd Entrance Step													
Heat Transfer - J/Hr-coolant													

RETROREFLECTIVE SHEETING DAYTIME COLOR SPECIFICATION

The daytime color of the RETROREFLECTIVE sheeting used to enhance school bus safety requires different color tolerances in order to assure optimum safety benefit, as well as to be consistent with the color of the school bus. The color of the RETROREFLECTIVE sheeting shall conform to the table below when samples applied to aluminum test panels are measured as specified in ASTM E1164. For colorimetric measurements, material is illuminated by Standard Illuminant D65 at an angle of 45 degrees with the normal to the surface the observations are made in the direction of the normal (45/0 degree geometry). The inverse (0/45 degree geometry) with the illuminant at the normal to the surface and the observations at 45 degrees with the normal to the surface may also be used. For materials which are directionally sensitive (e.g., prismatic sheeting), the colorimetric measurements are made using circumferential illumination and viewing and the various measurements are averaged. Calculations shall be done in accordance with ASTM E308 using the CIE 1931 (2 degree) Standard Observer.

Retroreflective Sheeting Daytime Color Chromaticity Coordinates of Corner Points Determining the Permitted Color Area

	1	2	3	4
Yellow X	0.484	0.513	0.517	0.544
Y	0.455	0.426	0.482	0.455
Luminance Factor (Y%)		Minimum	10.0	
		Maximum	36.0	

PLACEMENT OF REFLECTIVE MARKINGS AND WHITE ROOF

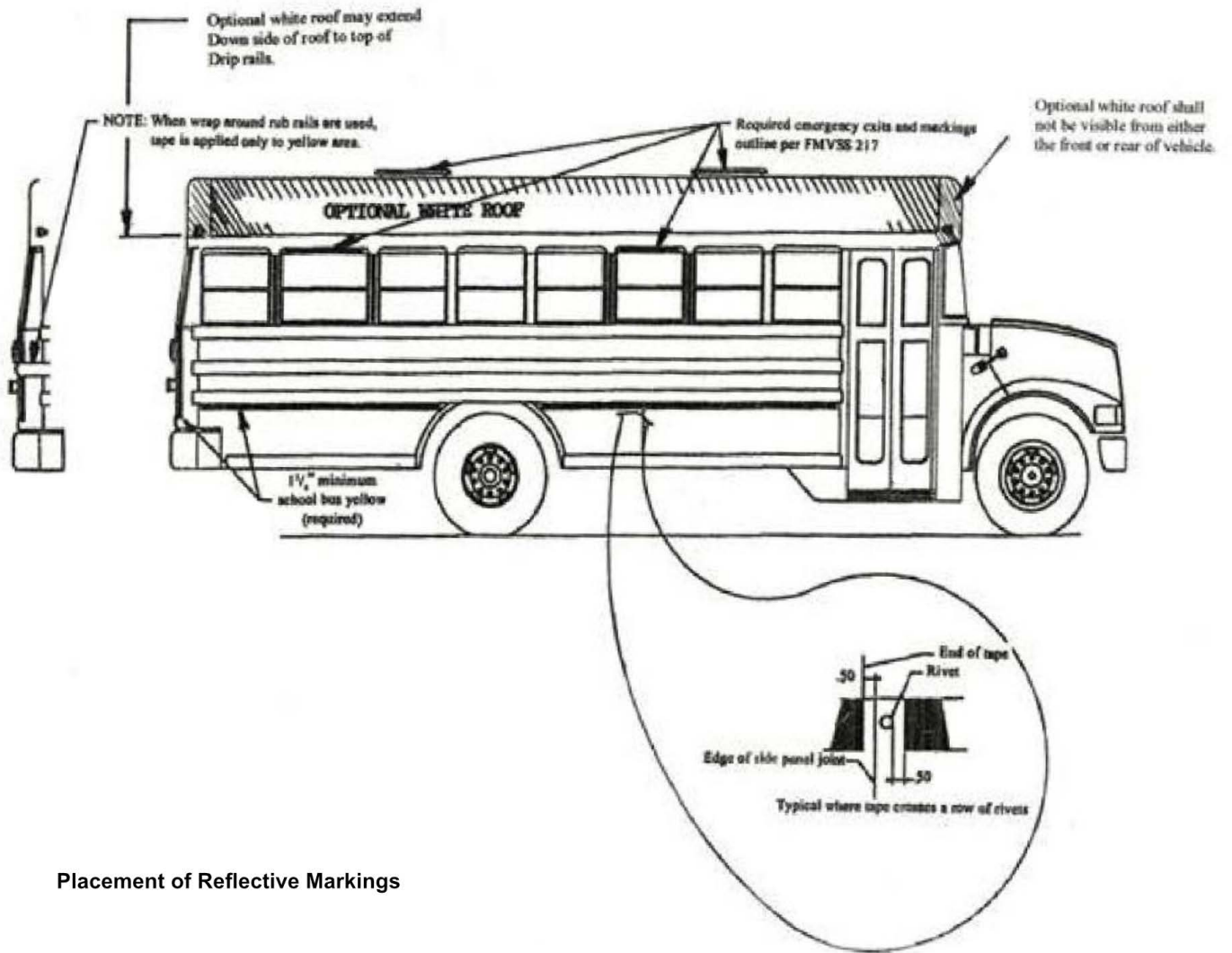

Placement of Reflective Markings

PLACEMENT OF RETROREFLECTIVE MARKINGS

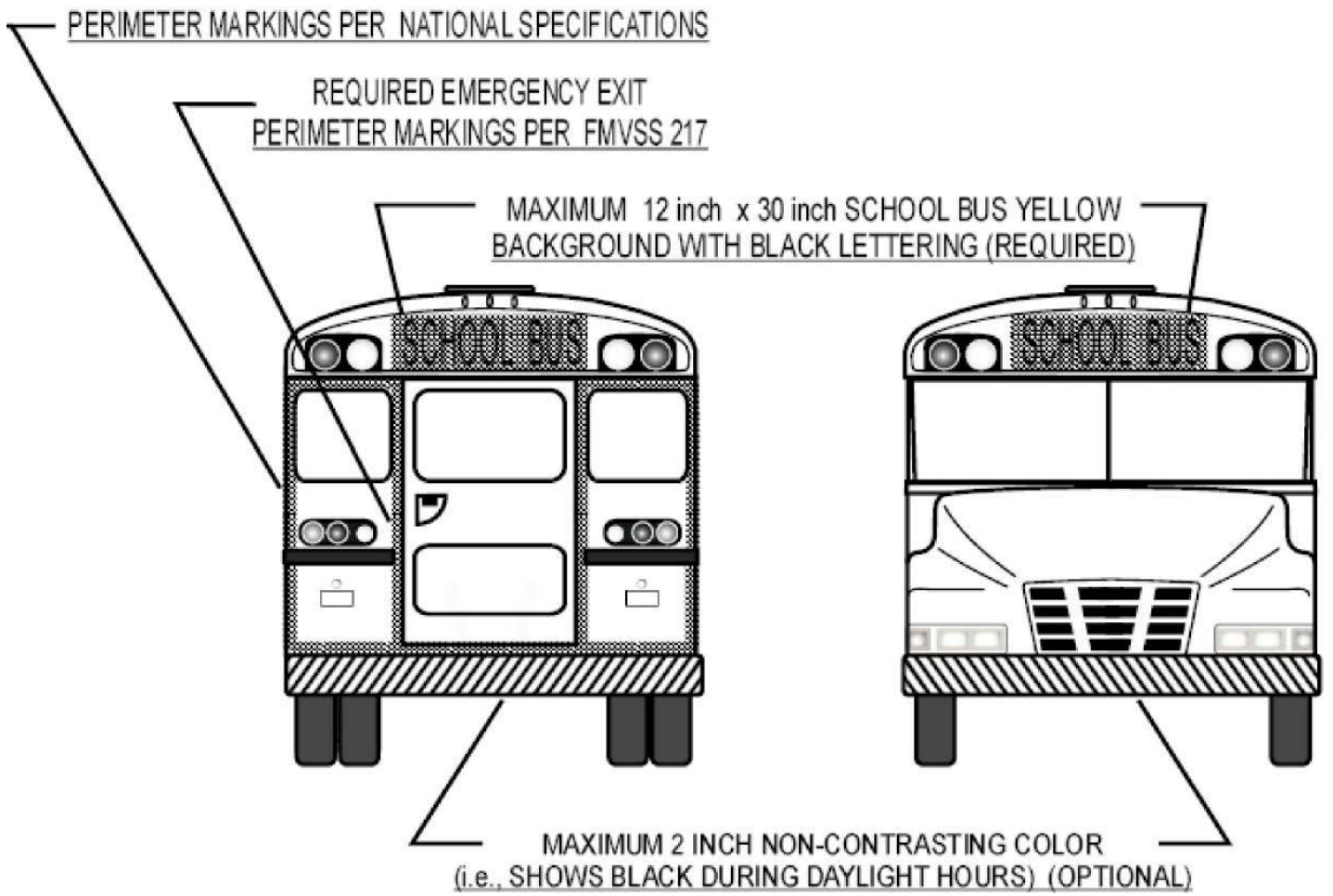

NOISE TEST PROCEDURE

- A. The vehicle is located so that no other vehicle or signboard, building, hill or other large reflecting surface is within 15.2 m (50 feet) of the occupant's seating position.
- B. All vehicle doors, windows and ventilators are closed.
- C. All power-operated accessories are turned off.
- D. The driver is in the normal seated driving position and the person conducting the test is the only other person in the vehicle.
- E. A sound level meter is used that is set at the "A-weighting fast" meter response and meets the requirements of:
 1. The American National Standards Institute, Standard ANSI S1.4-1971: Specifications for Sound Level Meters, for Type 1 Meters; or
 2. The International Electrotechnical Commission (IEC), Publication No. 179 (1973): Precision Sound Level Meters.
- F. The microphone is located so that it points vertically upward 6 inches to the right and directly in line with, and on the same plane as, the occupant's ear, adjacent to the primary noise source.
- G. If the motor vehicle's engine radiator fan drive is equipped with a clutch or similar device that automatically either reduces the rotational speed of the fan or completely disengages the fan from its power source in response to reduced engine cooling loads, the vehicle may be parked before testing with its engine running at high idle or any other speed the operator chooses for sufficient time, but not more than 10 minutes, to permit the engine radiator fan to automatically disengage.
- H. With the vehicle's transmission in neutral gear, the engine is accelerated to:
 1. Its maximum governed speed, if it is equipped with an engine governor; or
 2. Its speed at its maximum rated horsepower, if it is not equipped with an engine governor, and the engine is stabilized at that speed.
- I. The A-weighted sound level reading on the sound level meter for the stabilized engine speed condition referred to in H.1. or H.2., above, is observed and, if it has not been influenced by extraneous noise sources, is recorded.
- J. The vehicle's engine speed is returned to idle and the procedures set out in paragraphs H. and I. are repeated until 2 maximum sound levels within 2 dBA of each other are recorded. The 2 maximum sound level readings are then averaged; and
- K. The average obtained in accordance with paragraph J., with a value of 2 dBA subtracted there from to allow for variations in the test conditions and in the capabilities of meters, is the vehicle's interior sound level at the driver's seating position for the purposes of determining compliance with the requirements of this test procedure.

SCHOOL BUS SEAT UPHOLSTERY FIRE BLOCK TEST

A. Test Chamber

Cross Section

The suggested test chamber is the same cross section as the bus body in which seats are used with the rear section on each end. If a bus section is not used, the cross section is to be 91±1 inch in width x 75 inches ±3 inches in height. There shall be a door, which does not provide ventilation, in the center of each end of the test chamber. The doors shall be 38±3 inches in width and 53±3 inches in height and include a latch to keep the doors closed during the test. (See Figure 1.)

Length

The length of the test chamber shall allow three rows of seats at the minimum spacing recommended by the installer. (See Figure 1, Detail A.)

In order that different types of seats may be tested in the same chamber, a length tolerance of plus 45 inches is allowed.

Ventilation

One ventilation opening shall be in each end of the test chamber and shall be 325 square inches ±25 square inches. The bottom of the opening shall be 30 inches ±3 inches above the chamber floor. Ventilation openings shall be on the same side of the test chamber. (See Figure 1.)

There shall be no ventilation openings along the length of the test chamber. A forced-air ventilation system may not be used.

Baffles shall be used to prevent wind from blowing directly into the ventilation openings.

Camera View Area

An opening covered with glass shall be provided at the midpoint of the test chamber length for camera viewing. The opening shall allow the camera to view the seat parallel to the seat width. (See Figure 1.)

B. Test Sample

The sample shall be a fully assembled seat.

Record the weight of all padding and upholstery prior to assembly. Record the weight of the fully-assembled seat.

C. Ignition Source

A paper grocery bag with dimensions of approximately 7x11x18 inches is used to contain double sheets of newsprint (black print only, approximately 22x28 inches). The total combined weight of bag and newspaper shall be seven ounces ±0.5 ounces. After the newspaper is added to the paper bag, the two corners of the bag opening at each end of the 7" dimension may be stapled together using a single staple for newspaper retention if desired.

D. Test Procedure

1. Install three seats in the test chamber at minimum spacing, per installer recommendation. Seats shall be perpendicular to the dimension indicated as “length” in Figure 1. Install so that seat frames will not fall during the test. Seat width shall be determined so that maximum passenger capacity per row (two seats) for the seat style shall be tested.
2. For each test, position the ignition source in the following positions outlined. Figure 1

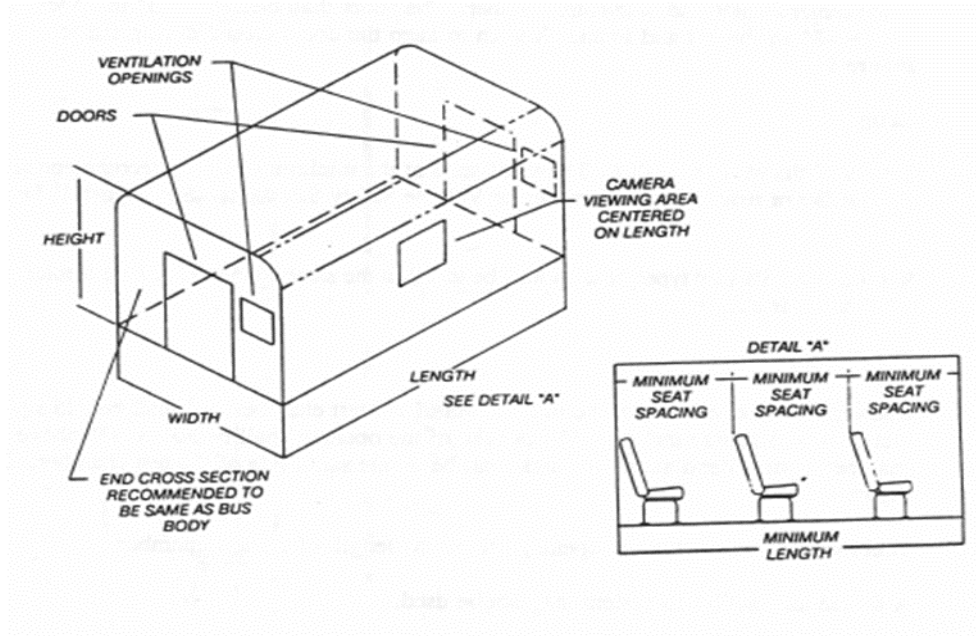

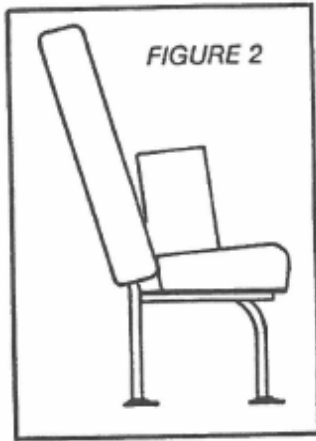

Position A

Position ignition source with 18-inch dimension in contact with the seat cushion and touching the seat back, the 11-inch dimension extending vertically from the surface of the cushion and the 7-inch dimension horizontal. Center the bag on top of the cushion. (See Figure 2.)

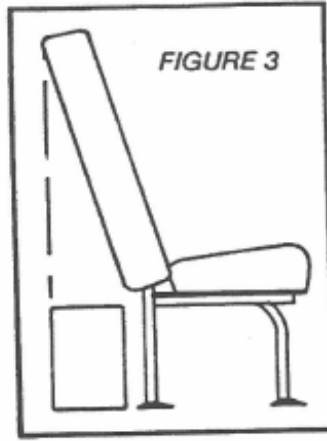

Position B.

Position the ignition source on the floor behind the seat with 18-inch side resting on the floor and parallel to seat width, centered on width so that the rear of bag does not extend beyond the rear seat back. (See Figure 3.)

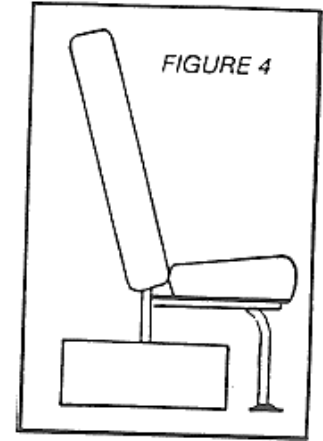

Position C.

Position the ignition source on the floor on the aisle side of the seat with 18-inch dimension on the floor and perpendicular to the seat width touching the seat leg, with centerline of the bag at the center of the seat back. (See Figure 4.)

3. A wooden match shall be used to light the ignition source. Time the test, beginning when the ignition source is on fire and ending when all flames are out.
4. After each ignition source position test, weigh seat assembly, including loose material which has fallen off the seat onto the floor.

E. Performance Criteria

For each ignition source position test, the seat tested must meet all of the following criteria. A new seat specimen may be used for each ignition source position test.

1. Maximum time from ignition to flameout shall be 8 minutes.
2. Flame shall not spread to any other seat with the ignition source in Position A and Position C.
3. Weight loss may not exceed 10% of the pretest weight of padding and upholstery. Padding and upholstery may be combined in the form of integrally bonded seat foam.

APPENDIX C: Bibliography for Alternative Fuels

BIBLIOGRAPHY

49 CFR Part 571, Federal Motor Vehicle Safety Standards. NHTSA (400 Seventh Street SW, Washington, DC 20590).

A.G.A. *Requirements for Natural Gas Vehicle (NGV) Conversion Kits*, No. 1-85. American Gas Association Laboratories, August 20, 1995.

An Alternative Transportation Fuel, "The LNG Option." Roy E. Adkins Cryogenic Fuels, Inc., September 1989.

An Analysis of the Economic and Environmental Effects of Natural Gas as An Alternative Fuel, EA 1989-10. December 15, 1989.

Basic Requirements for Compressed Natural Gas Vehicle (NGV) Fuel Containers, ANSI/AGA NGV2, American Gas Association Laboratories, 1992.

"CAA Clean Fuel Fleet Requirements." Presented by Glenn W. Passavant, U.S. EPA. 1992 SAE Government/Industry Meeting, Washington, D.C., April 30, 1992.

"Campaigning for NGV's": 4th Annual Meeting Proceedings. Dallas, Texas: The Natural Gas Vehicle Coalition, June 24-25, 1992.

Compressed Natural Gas Conference Proceedings, SAE P - 129 (compilation of papers). Pittsburgh, Pennsylvania, June 22-23, 1993.

Compressed Natural Gas (CNG) Demonstration Project: Transit Facility for Buses. M.S. Consultants, Inc. for the Ohio Department of Transportation, June 1991.

Compressed Natural Gas (CNG) Vehicular Fuel Systems, ANSI/NFPA 52 - 1988 Edition. National Fire Protection Association.

Directory of Natural Gas Vehicle Refueling Stations, Products and Services, 1991 & 1992 Editions American Gas Association.

"Extent of Indoor Flammable Plumes Resulting from CNG Bus Fuel System Leaks SAE 922486" by Michael J. Murphy, Susan T. Brown, & David B. Phillips-Battelle, November 1992.

Florida School Bus Alternate Fuel Manual. Florida Department of Education (Suite 824, 325 West Gaines Street, Tallahassee, FL 322399-0400), 1992.

Methanol Use in School Transportation: An Expedition Through the Mind Set of America, SAE 951966 by Wayne B. Johnston and George Karbowski. Presented to SAE Future Transportation Technology Conference and Exposition, Costa Mesa, CA.

National Biodiesel Board, compilation of papers, www.nbb.org, 1998 - 2005.

Potential for Compressed Natural Gas Vehicles in Centrally-Fueled Automobile, Truck and Bus Fleet Applications, by Michael E. Samsa. Gas Research Institute, Strategic Planning and Analysis Division, June 1991.

"Putting the Future of Methanol in Proper Perspective" by J.R. Crocco - Presented to 1992 SAE Government/ Industry Meeting, Washington, DC, April 1992.

Technology Conference Proceedings, The Natural Gas Vehicle Coalition, Dallas, Texas, June 24-25, 1992.

APPENDIX D: Sample Procedures and Forms

SAMPLE PROCEDURE FOR DOCUMENTING SCHOOL BUS PURCHASES

1. Owner/operator makes written request to Transportation Department to purchase a new or pre-owned school bus. (See sample form, “Request to Purchase a New or Pre-Owned School Bus.”)
2. The Transportation Supervisor schedules and conducts a route audit, recording the mileage to be frozen, if applicable.
3. The Transportation Supervisor prescribes the bus capacity due to the formula for calculating operational compensation. (Note: if the owner/operator insists on purchasing a larger-than-authorized school bus, the Transportation Supervisor may approve the purchase provided that the owner/operators signs an agreement to be compensated at the rate prescribed for the authorized capacity.)
4. The Transportation Supervisor explains the requirements for meeting or exceeding Federal Motor Vehicle Safety Standards and Louisiana-specific requirements.
5. The Transportation Supervisor issues a written authorization for the owner/operator to purchase a vehicle and provides a Louisiana Department of Education Form T-10 (copy attached) for the vendor, purchaser and school district representative to complete.
6. The Transportation Supervisor distributes copies of the completed Form T-10 when the bus is placed into service on the route.
7. The Transportation Supervisor notifies the Payroll Department if frozen mileage applies, the amount of frozen mileage and the number of years for which mileage is frozen in accordance with Louisiana Revised Statutes (*i.e.*, 7 years for new school buses, 5 years for pre-owned school buses not more than five model years old, zero years for pre-owned school buses more than five model years old).
8. Copies of Form T-10’s are maintained in the official files of the school district and submitted to the Louisiana Department of Education upon request.

(SAMPLE)

_____ Public School System

REQUEST TO PURCHASE A NEW OR PRE-OWNED SCHOOL BUS

TO: TRANSPORTATION DEPARTMENT

I, _____, hereby request approval to purchase a school bus, as
(Name)

described below, to be placed into service in the _____ School District:

____ New ____ Pre-owned (check one) _____ Model Year _____ Capacity

Lift-equipped? ____ Yes ____ No (check one)

I understand that the vehicle must be certified as a school bus, that it must meet all Federal Motor Vehicle Safety Standards and Louisiana specifications and that my route must be audited before the bus is purchased and placed into service. I further understand that if the school bus is five (5) model years old or less, sales tax exemption and “frozen mileage” apply, but **if the school bus is more than five (5) model years old, neither sales tax exemption nor “frozen mileage” apply.**

Present Bus Model Year: _____ Present Bus Capacity: _____

Present Route Mileage (One-Way) _____ Present Number of Students Transported: _____

I acknowledge that any change in the model year, capacity or specialized equipment must be approved by the authorized school district representative before a sale is finalized.

(Signature)

(Current Date)

(FOR OFFICE USE ONLY)

I hereby authorize _____ to purchase a school bus as described above.
(Name)

Upon completion of a route audit, I shall provide the prospective purchaser with a Louisiana Department of Education Form T-10, which must be completed by the vendor and the purchaser before submitting the document to me or my designee for completion.

(Signature)

(Print/Type Name)

(Title)

(Current Date)

MANDATORY

This form MUST be completed by the vendor, purchaser and school district official for every school bus (new or pre-owned) purchased by individuals or by school districts in Louisiana. A copy of the T-10 shall be provided to the Louisiana Department of Education upon request.

AUDITED MILEAGE*: _____ DATE AUDITED*: _____

AUDITED BY*: _____ GUARANTEED (“FROZEN”) MILEAGE**: _____
*Applicable to owner/operators **[See Louisiana Revised Statute 17:497.D(1).]

DATE OF PURCHASE AGREEMENT: _____

I propose to sell to _____ the following described NEW/PRE-OWNED school bus: _____ (Name of Owner/Operator or School Board) _____ (Circle One)

CHASSIS

BODY

MODEL YEAR _____
MANUFACTURER _____
VIN NUMBER _____
MILEAGE _____
CONDITION _____

MODEL YEAR _____
MANUFACTURER _____
RATED CAPACITY _____
CERTIFIED SCHOOL BUS _____ YES _____ NO
CONDITION _____

I hereby certify that the SCHOOL BUS described above meets or exceeds all applicable Federal Motor Vehicle Safety Standards, Head Start Standards and Louisiana Department of Education requirements at the time of manufacture and any and all applicable retrofit requirements (including, but not limited to, backup alarm, crossing control arm, two stop signals). Further, I verify that the above information is true and correct to the best of my knowledge.

(Signature of Vendor or Authorized Representative) _____
(Company or Individual Name) _____
(Company or Individual Address) _____
(Address Continued) _____

(Company or Individual Phone No.) _____
(Official Purchase Agreement Date) _____
(Vehicle License No.) _____
(Telephone No.) _____

(Name of Purchaser) _____
(Signature of Purchaser or Agent) _____
(Telephone No. of Purchaser or Agent) _____

(Address of Purchaser) _____
(Address Continued) _____
(Date of Acceptance) _____

APPROVAL OF LOCAL SCHOOL DISTRICT

(Name of Local School System Agent) _____
(Title) _____

(Date of Approval) _____
(Date Bus Placed on Route or Assigned for Activities) _____

Beginning and Ending Dates of Frozen Mileage, if Applicable: From _____ To _____

(Copies to: Local Transportation Department (if applicable), Vendor, Purchaser, LDOE upon request)

Jolly Time Head Start
 2001 Tornado Drive
 Windy City, MD 65432

STATEMENT OF HEAD START VEHICLE COMPLIANCE

I, _____, certify that the vehicle described below meets or exceeds all applicable Federal and State chassis and body design and construction requirements and all bid specification requirements issued by or authorized by the Head Start Agency or Agency Representative listed above. I acknowledge that at the time of delivery, each vehicle shall be inspected by the Agency’s designee to ensure compliance as required.

CHASSIS

BODY

Make _____
 Year Model _____
 Vin Number _____
 Mileage _____
 Condition _____

Make _____
 Year Model _____
 GVWR _____
 Passenger Capacity _____
 CSRS Type _____

 Signature (Vendor’s Representative)

 Name of Vendor

 Official Purchase Date

 Number/Street/P.O. Box

 Occupational License Number

 City/State/Zip

 Telephone Number

 Fax Number

FOR OFFICE USE ONLY

Vehicle Delivery Date: _____ Vehicle Inspection Date: _____
 Vehicle Acceptance Date: _____ Accepted By: _____

SCHOOL BUS INSPECTION CHECKLIST
Inspection Date: _____

OWNER: _____ BUS NO. _____ YEAR MODEL: _____

STATE INSPECTION STICKER DATE: _____ INSPECTOR(S): _____

INSPECT BUS FRONT		GOOD	CAUTION	REPAIR
1	Bumper—gloss black			
2	Crossing control arm			
3	Cross-view mirrors			
4	Flashing stop lamps			
5	Turn signals			
6	Four-way hazard lamps			
7	Running lights			
8	Low/high beam head lights			
9	Parking lights			
10	3 amber identification lamps			
11	Hood latches			
12	Front rims, studs, lugs			
13	Wheel color—black or gray			
14	Front tires			

INSPECT DRIVER'S SIDE		GOOD	CAUTION	REPAIR
15	Side view mirrors			
16	Side marker lamps			
17	Side reflectors			
18	Owner's name—block letters			
19	Stop arms/lamps/lettering			
20	"St. Helena Parish Schools"			

INSPECT BUS REAR		GOOD	CAUTION	REPAIR
21	2 red reflectors			
22	Backup lamps			
23	Backup alarm			
24	Brake, tail, turning lamps			
25	Hazard lamps			
26	3 red identification lamps			
27	Flashing stop lamps			
28	Strobe lamp (if applicable)			
29	Emergency exit lettering			
30	Emergency door/gasket			
31	Emergency door buzzer			
32	Reflective striping			
33	Bumper—gloss black			
34	Mud flaps			
35	Tail pipe/hangers			
36	Bus number			
37	Unauthorized signage			
38	4 rear tires			

INSPECT PASSENGER'S SIDE		GOOD	CAUTION	REPAIR
39	Side marker lamps			
40	Side reflectors			
41	Fuel filler door/cap			
42	"Drug-free zone" lettering			
43	"Weapons-free zone" lettering			
44	Side view mirrors			
45	Entrance door/gasket			

INSPECT BUS INTERIOR		GOOD	CAUTION	REPAIR
46	Stepwell/dome lamps			
47	Steps/treads (covering)			
48	Driver's seat belt			
49	Horn			
50	Gauges			
51	Rearview mirror			
52	Windshield washer/wipers			
53	First aid kit			
54	Fire extinguisher			
55	Reflective triangles			
56	Windshield			
57	Driver's window			
58	Passenger windows			
59	Emergency windows/buzzers			
60	Escape hatch(es)			
61	Passenger seats			
62	Graffiti			
63	Interior cleanliness			
64	Unauthorized signage			
65	Unauthorized objects			
66	Unattached objects			

MISCELLANEOUS ITEMS		GOOD	CAUTION	REPAIR
67	Exterior cleanliness			
68	Exterior body/chassis paint			
69	Exterior numbers/letters paint			

COMMENTS

