



MEMO

DATE: June 19, 2014

TO: Design Advisory Committee (DAC)

FROM: Brendan Matthews, Chief Maintenance Officer, Veolia Transdev in service to the Regional Transit Authority

SUBJECT: Request to Install Non-Advertising Bus Benches at Downtown Bus Stop Zones

The Regional Transit Authority is request DAC approval for DPW to permit sixteen (16) non-advertising eight-foot benches with four seats and anti-vagrant bars at the following downtown locations (Table 1).

Table 1 – Proposed Bench Locations

Overall On Rank	Bus On Rank	stop_id	stop_name	On	Off	Total	Bench	Zone	Line1	Line2	Line3	Line4	Line5	Line6
3	2	990	Elk Place at Canal	1,126	715	1,841	4	A	62	63	64			
9	6	753	Elk Place at Tulane	479	128	607	4	C	39	51	52	62	63	64
2	1	446	S. Rampart at Canal	1,204	1,311	2,515	3	H	57	88	91			
39	14	8274	S. Rampart at Canal	165	239	404	3	I	91					
6	4	752	Saratoga at Canal	645	0	645	2	O	39					

Reasons for Request

The RTA Board of Commissioners along with City Council has been concerned with the lack of seating at major bus stop in the downtown area and has directed staff to identify opportunities for installing benches. Over 5,000 riders board downtown bus stops on a daily basis. Bench installation is an interim solution as RTA has funded a site selection study for a downtown transit center. RTA has met with Tulane University staff to review bench locations at Bus Zone A (Elk Place at Canal Street) and has revised our proposal to reflect their concerns. The benches are proposed to be the same silver model that have been installed in non-advertising streetcar shelters along Canal Street.

Attachments

- Surveys of Proposed Bench Locations
- Google Streetview Pictures of Bus Zones where Bus Benches are proposed to be installed
- Bus Bench color rendering
- Bus Bench diagram
- Bus Bench Photo from Streetcar Shelters
- Downtown Bus Zones

Questions:

Please contact Brendan Matthews at (504) 827-8383 or brendan.matthews@veoliatransdev.com or Stefan Marks AICP at (504) 606-6086 or stefan.marks@veoliatrasndev.com.

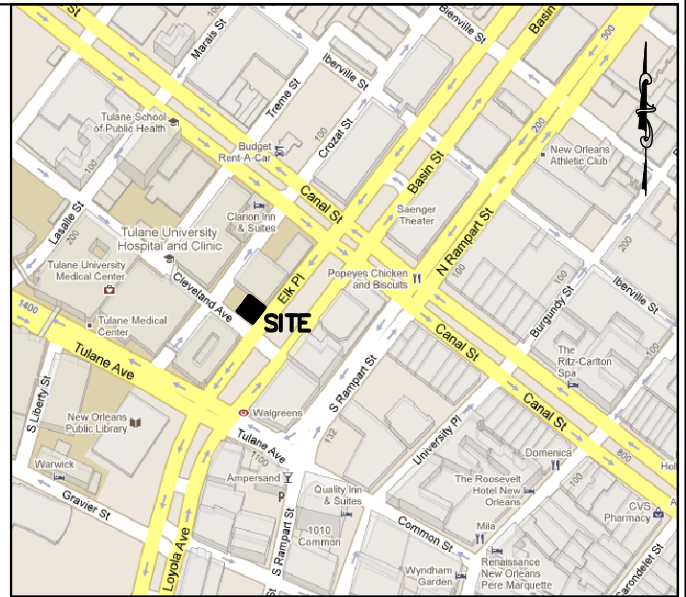
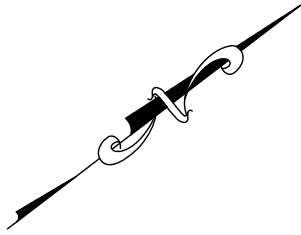

VICINITY MAP

CLEVELAND AVENUE

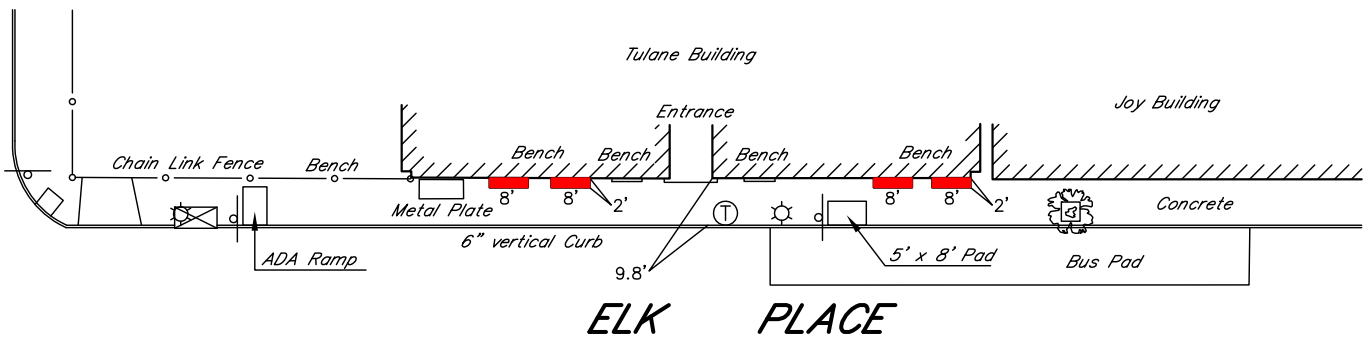

LEGEND

- | | | | |
|---|--------------------|---|--------------------|
| ⊙ | SEWER MANHOLE | ⊙ | GAS MANHOLE |
| ⊙ | SEWER CLEANOUT | ⊙ | GAS METER |
| ⊙ | DRAIN MANHOLE | ⊙ | GAS VALVE |
| ⊙ | DRAIN INLET ROUND | ⊙ | TELEPHONE MANHOLE |
| ⊙ | DRAIN INLET SQUARE | ⊙ | TELEPHONE PEDESTAL |
| ⊙ | DRAIN CLEANOUT | ⊙ | ELECTRIC MANHOLE |
| ⊙ | CATCH BASIN | ⊙ | WOOD POLE |
| ⊙ | WATER MANHOLE | ⊙ | LIGHT STANDARD |
| ⊙ | WATER METER | ⊙ | SIGN |
| ⊙ | WATER VALVE | ⊙ | TREE |
| ⊙ | FIRE HYDRANT | | |

DEPARTMENT OF PUBLIC WORKS
 TRAFFIC ENGINEERING: _____
 APPROVAL: _____ DATE: _____

NOTES:



**TRANSIT SHELTER PLAN
 ELK PLACE AT CLEVELAND AVE.
 ORLEANS PARISH, LOUISIANA**

REVISIONS			
NO.	DATE	DESCRIPTION	BY

PREPARED BY:
LANDMARK SURVEYING, INC.
 1513 KUEBEL STREET
 Harahan, Louisiana 70123
 Fax: 504-734-8357 Phone: 504-733-3303

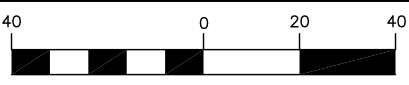

(IN FEET)
 1 inch = 40 ft.

Date: 4-21-14
 Scale: 1"=40'
 Job No: 14-0101
 Plot File No: 140101

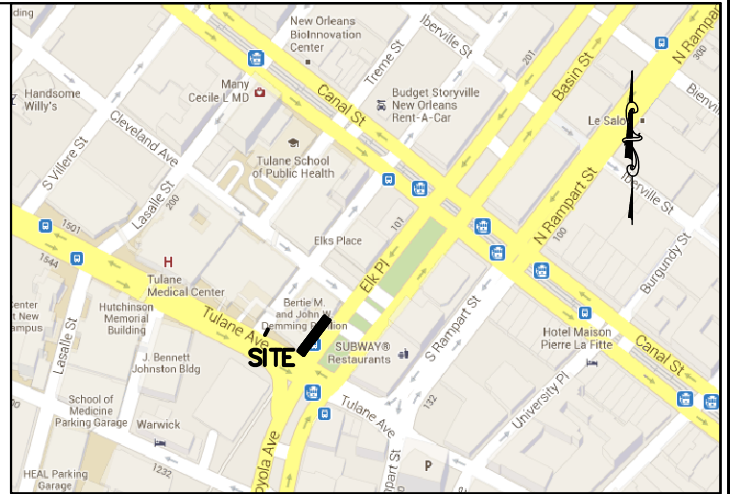
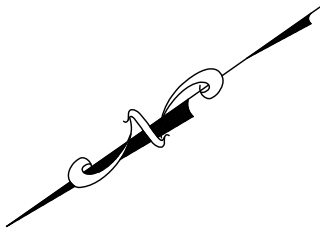

VICINITY MAP

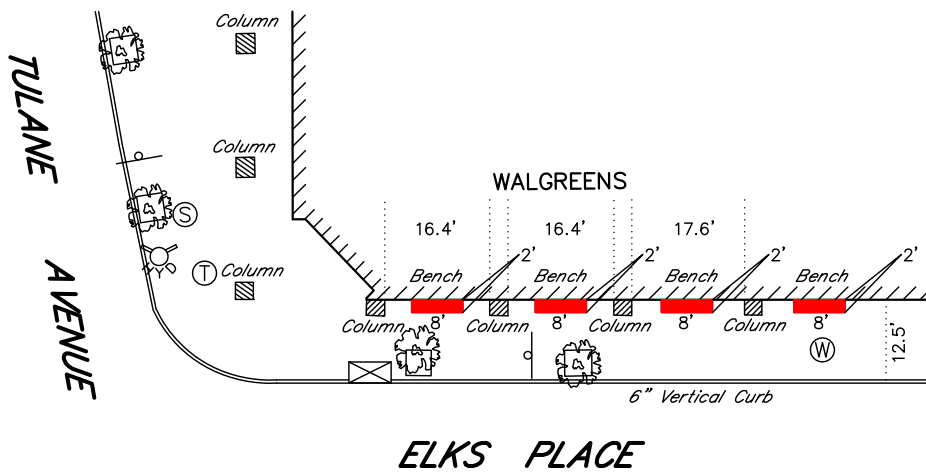

LEGEND

⊙	SEWER MANHOLE	⊙	GAS MANHOLE
⊙	SEWER CLEANOUT	⊙	GAS METER
⊙	DRAIN MANHOLE	⊙	GAS VALVE
⊙	DRAIN INLET ROUND	⊙	TELEPHONE MANHOLE
⊙	DRAIN INLET SQUARE	⊙	TELEPHONE PEDESTAL
⊙	DRAIN CLEANOUT	⊙	ELECTRIC MANHOLE
⊙	CATCH BASIN	⊙	WOOD POLE
⊙	WATER MANHOLE	⊙	LIGHT STANDARD
⊙	WATER METER	⊙	SIGN
⊙	WATER VALVE	⊙	TREE
⊙	FIRE HYDRANT		

DEPARTMENT OF PUBLIC WORKS
 TRAFFIC ENGINEERING: _____
 APPROVAL: _____ DATE: _____

NOTES:

REQUESTED BY:

**TRANSIT SHELTER PLAN
 ELKS PL. AT TULANE AVE,
 ORLEANS PARISH, LOUISIANA**

REVISIONS

NO.	DATE	DESCRIPTION	BY

PREPARED BY:

 1513 KUBBEL STREET
 Harahan, Louisiana 70123

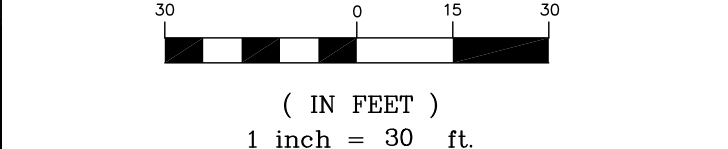

Date: 4-23-14
 Scale: 1"=30'
 Job No: 14-0097
 Plat File No: 140097

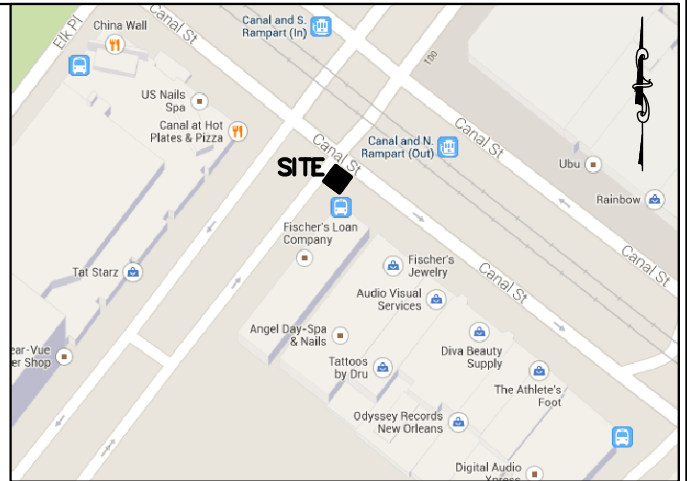
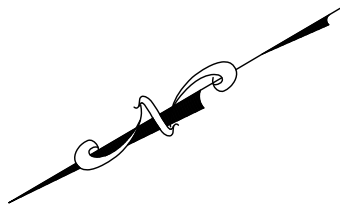

VICINITY MAP

CANAL STREET

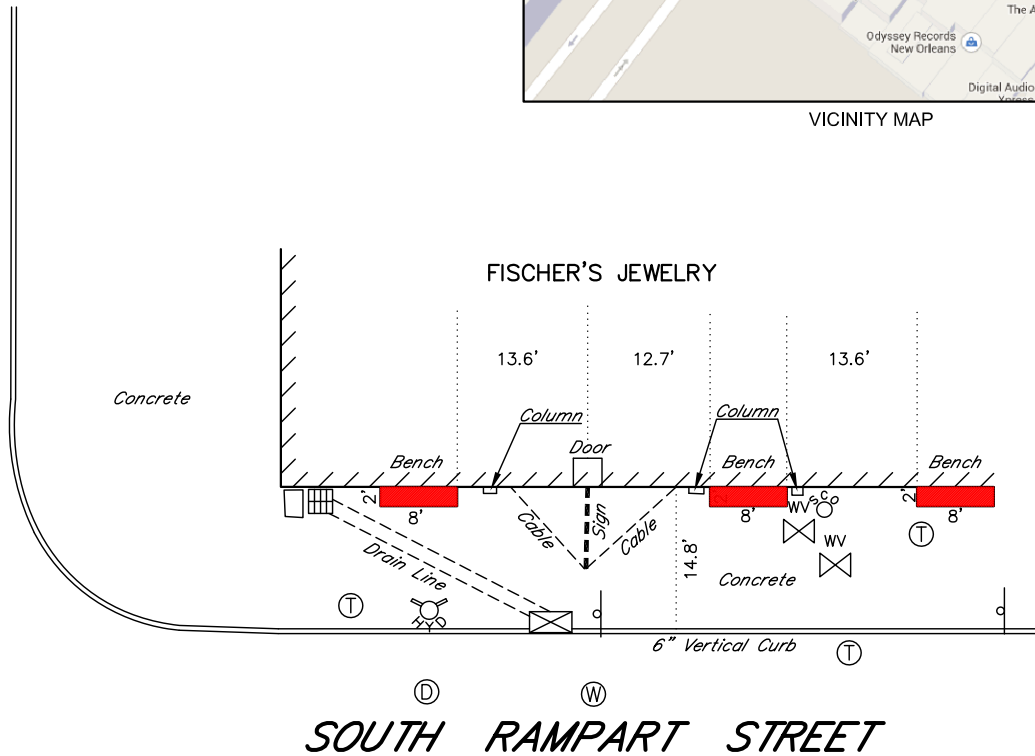

LEGEND

- | | | | |
|---|--------------------|---|--------------------|
| ⊙ | SEWER MANHOLE | ⊙ | GAS MANHOLE |
| ⊙ | SEWER CLEANOUT | ⊙ | GAS METER |
| ⊙ | DRAIN MANHOLE | ⊙ | GAS VALVE |
| ⊙ | DRAIN INLET ROUND | ⊙ | TELEPHONE MANHOLE |
| ⊙ | DRAIN INLET SQUARE | ⊙ | TELEPHONE PEDESTAL |
| ⊙ | DRAIN CLEANOUT | ⊙ | ELECTRIC MANHOLE |
| ⊙ | CATCH BASIN | ⊙ | WOOD POLE |
| ⊙ | WATER MANHOLE | ⊙ | LIGHT STANDARD |
| ⊙ | WATER METER | ⊙ | SIGN |
| ⊙ | WATER VALVE | ⊙ | TREE |
| ⊙ | FIRE HYDRANT | | |

DEPARTMENT OF PUBLIC WORKS
TRAFFIC ENGINEERING: _____

NOTES:

APPROVAL: _____ DATE: _____

REQUESTED BY:



**TRANSIT SHELTER PLAN
S. RAMPART ST. AT CANAL ST.
ORLEANS PARISH, LOUISIANA**

REVISIONS

PREPARED BY:

LANDMARK SURVEYING, INC.
1513 KUBBEL STREET
Harahan, Louisiana 70123

Fax: 504-734-8397

Phone: 504-733-3303

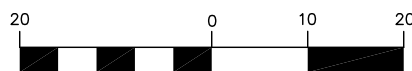

(IN FEET)
1 inch = 20 ft.

NO.	DATE	DESCRIPTION	BY

Date: 4-17-14
Scale: 1"=20'
Job No: 14-0104
Plot File No: 140104

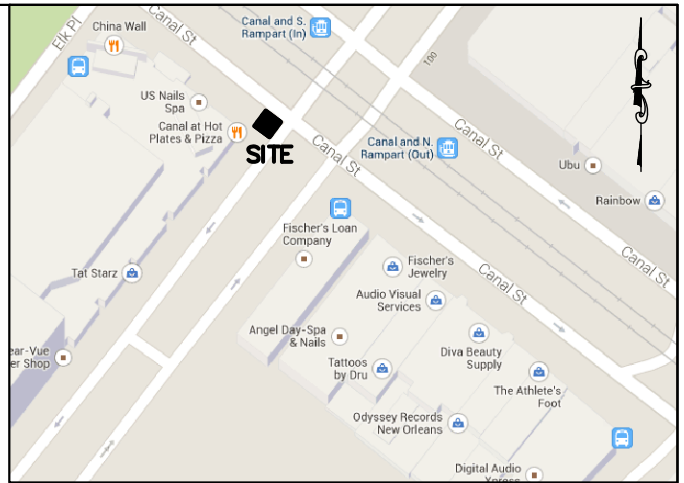

VICINITY MAP

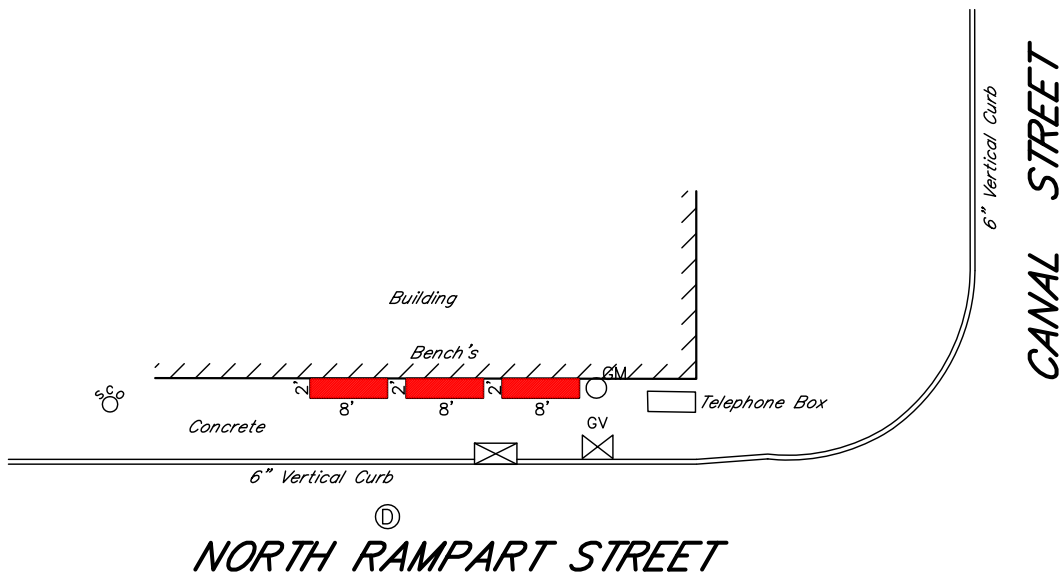

LEGEND

- | | | | |
|---|--------------------|---|--------------------|
| ⊙ | SEWER MANHOLE | ⊙ | GAS MANHOLE |
| ⊙ | SEWER CLEANOUT | ⊙ | GAS METER |
| ⊙ | DRAIN MANHOLE | ⊙ | GAS VALVE |
| ⊙ | DRAIN INLET ROUND | ⊙ | TELEPHONE MANHOLE |
| ⊙ | DRAIN INLET SQUARE | ⊙ | TELEPHONE PEDESTAL |
| ⊙ | DRAIN CLEANOUT | ⊙ | ELECTRIC MANHOLE |
| ⊙ | CATCH BASIN | ⊙ | WOOD POLE |
| ⊙ | WATER MANHOLE | ⊙ | LIGHT STANDARD |
| ⊙ | WATER METER | ⊙ | SIGN |
| ⊙ | WATER VALVE | ⊙ | TREE |
| ⊙ | FIRE HYDRANT | | |

DEPARTMENT OF PUBLIC WORKS
TRAFFIC ENGINEERING: _____

NOTES:

APPROVAL: _____ DATE: _____

REQUESTED BY:



**TRANSIT SHELTER PLAN
N. RAMPART ST. AT CANAL ST.
ORLEANS PARISH, LOUISIANA**

REVISIONS

PREPARED BY:

LANDMARK SURVEYING, INC.
1513 KUEBEL STREET
Harahan, Louisiana 70123

Fax: 504-734-8357

Phone: 504-733-3303

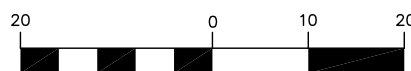

(IN FEET)
1 inch = 20 ft.

NO.	DATE	DESCRIPTION	BY

Date: 4-17-14
Scale: 1"=20'
Job No: 14-0098
Plot File No: 140098

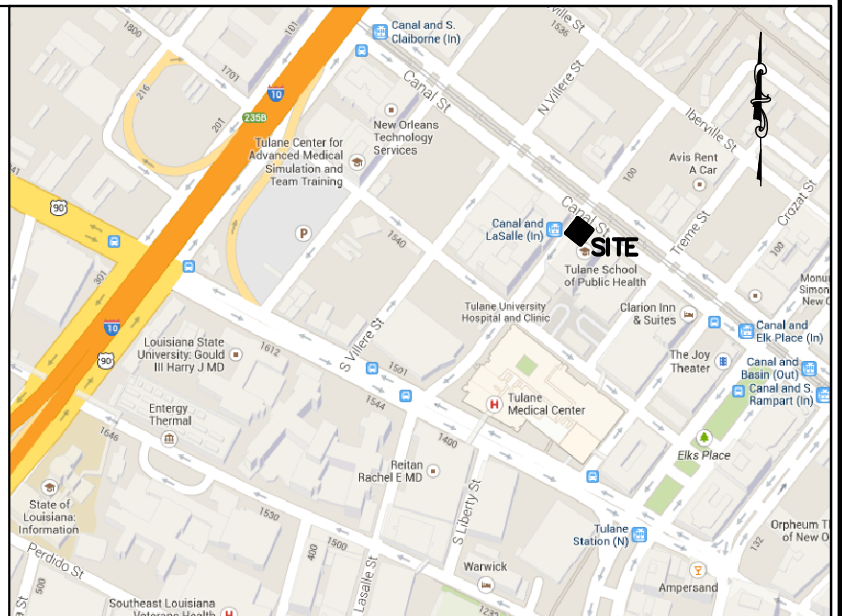
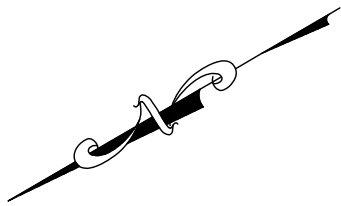

VICINITY MAP

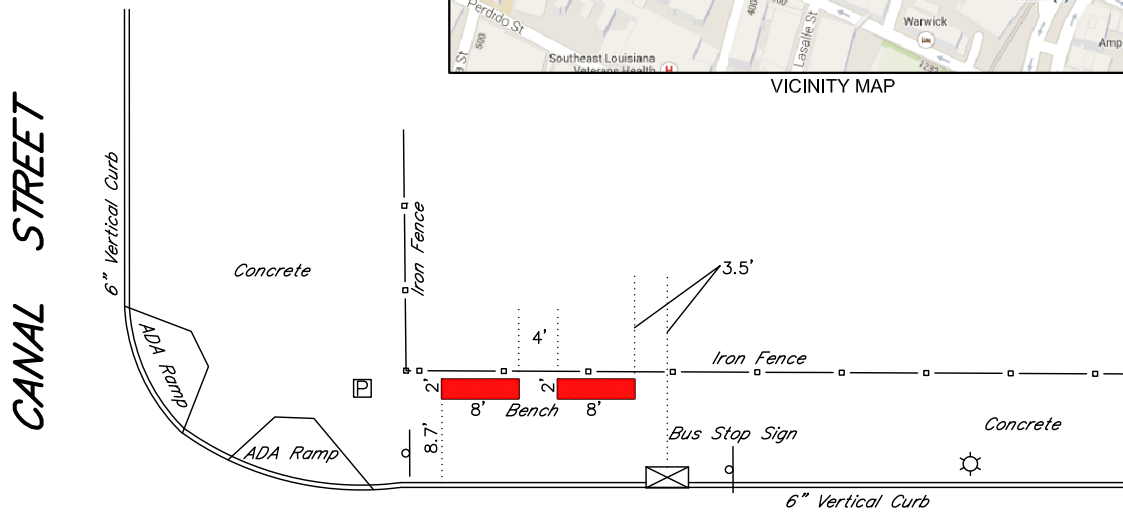

SOUTH SARATOGA STREET

LEGEND

- | | | | |
|---|--------------------|---|--------------------|
| ⊗ | SEWER MANHOLE | ⊗ | GAS MANHOLE |
| ⊕ | SEWER CLEANOUT | ⊗ | GAS METER |
| ⊙ | DRAIN MANHOLE | ⊗ | GAS VALVE |
| ⊕ | DRAIN INLET ROUND | ⊗ | TELEPHONE MANHOLE |
| ⊕ | DRAIN INLET SQUARE | ⊗ | TELEPHONE PEDESTAL |
| ⊕ | DRAIN CLEANOUT | ⊗ | ELECTRIC MANHOLE |
| ⊕ | CATCH BASIN | ⊗ | WOOD POLE |
| ⊕ | WATER MANHOLE | ⊗ | LIGHT STANDARD |
| ⊕ | WATER METER | ⊗ | SIGN |
| ⊕ | WATER VALVE | ⊗ | TREE |
| ⊕ | FIRE HYDRANT | | |

DEPARTMENT OF PUBLIC WORKS
TRAFFIC ENGINEERING: _____

NOTES:

APPROVAL: _____ DATE: _____

REQUESTED BY:



**TRANSIT SHELTER PLAN
S. SARATOGA ST. AT CANAL ST.
ORLEANS PARISH, LOUISIANA**

REVISIONS

PREPARED BY:

LANDMARK SURVEYING, INC.
1513 RUEBEL STREET
Harahan, Louisiana 70123

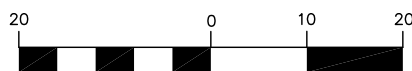

(IN FEET)
1 inch = 20 ft.

NO.	DATE	DESCRIPTION	BY

Date: 4-21-14
Scale: 1"=20'
Job No: 14-0100
Plot File No: 140100

Zone A – Elk Place at Canal Street

Google from: Southern University, 6400 Press Dr, New Orleans, LA 70126 to: Canal St & S Sign in

Get directions My places

1:50pm - 2:06pm

- 25 mins
1:52pm - 2:17pm
- 22 mins
2:04pm - 2:26pm
- 15 mins
2:20pm - 2:36pm

Transit directions to Cleveland Ave

- A** Old St Bernard St
New Orleans, LA 70116
 - Walk to St Bernard at N. Prieur
About 4 mins (0.2 mi)
- O** St Bernard at N. Prieur Stop ID: N1128
 - 52 Bus towards Canal Street via St. Anthony Avenue
1:54pm - 2:06pm (11 mins, 12 stops)
- O** Elk Place at Cleveland
- B** Cleveland Ave

Travel time: about 15 mins

Local agency information:
Contains more information on fares, schedules, and service advisories
New Orleans RTA - (504) 248-3900

These directions are for planning purposes only. You may find that construction projects, traffic, weather, or other events may cause conditions to differ from the map results, and you should plan your route accordingly. You must obey all signs or

© 2014 Google Image Date: January 2014

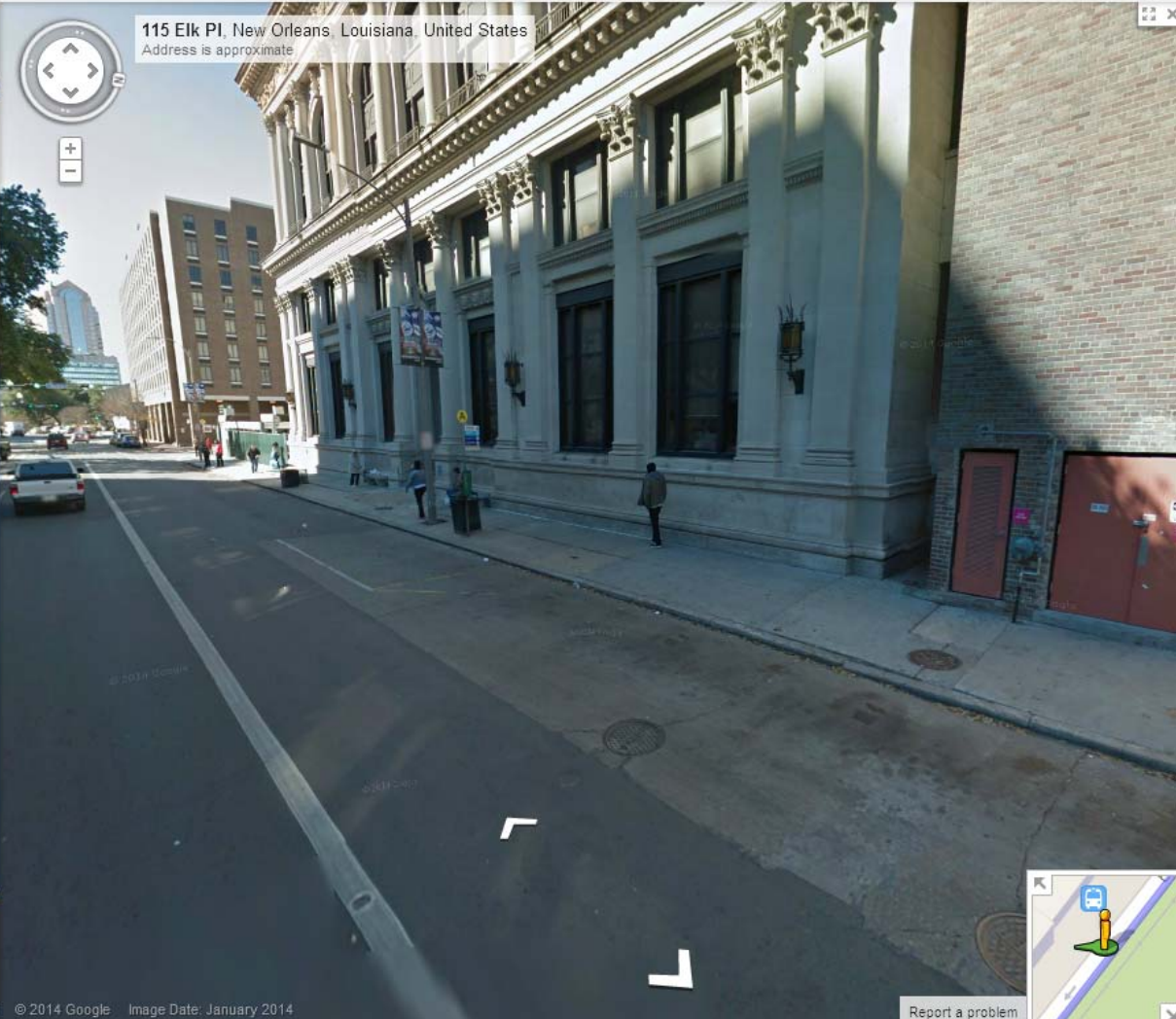

Zone C – Elk Place at Tulane

Veolia Transportation | Route Status | The National Transit D... | SolarOS - Login | /localhost:8765/ | Monthly Statistics | Log In - Confluence | Listen Express | Amber and Stefan | Error | Transit Tracker Login

Google | from: Southern University, 6400 Press Dr, New Orleans, LA 70126 to: Canal St & S | Sign in

Get directions | My places

1:50pm - 2:06pm	25 mins
1:52pm - 2:17pm	
2:04pm - 2:26pm	22 mins
2:20pm - 2:36pm	15 mins

Transit directions to Cleveland Ave

- A** Old St Bernard St
New Orleans, LA 70116
Walk to St Bernard at N. Prieur
About 4 mins (0.2 mi)
- St Bernard at N. Prieur** Stop ID: N1128
52 Bus towards Canal Street via St. Anthony Avenue
1:54pm - 2:06pm (11 mins, 12 stops)
- Elk Place at Cleveland**
- B** Cleveland Ave

Travel time: about 15 mins

Local agency information:
Contains more information on fares, schedules, and service advisories
[New Orleans RTA - \(504\) 248-3900](#)

These directions are for planning purposes only. You may find that construction projects, traffic, weather, or other events may cause conditions to differ from the map results, and you should plan your route accordingly. You must obey all signs or

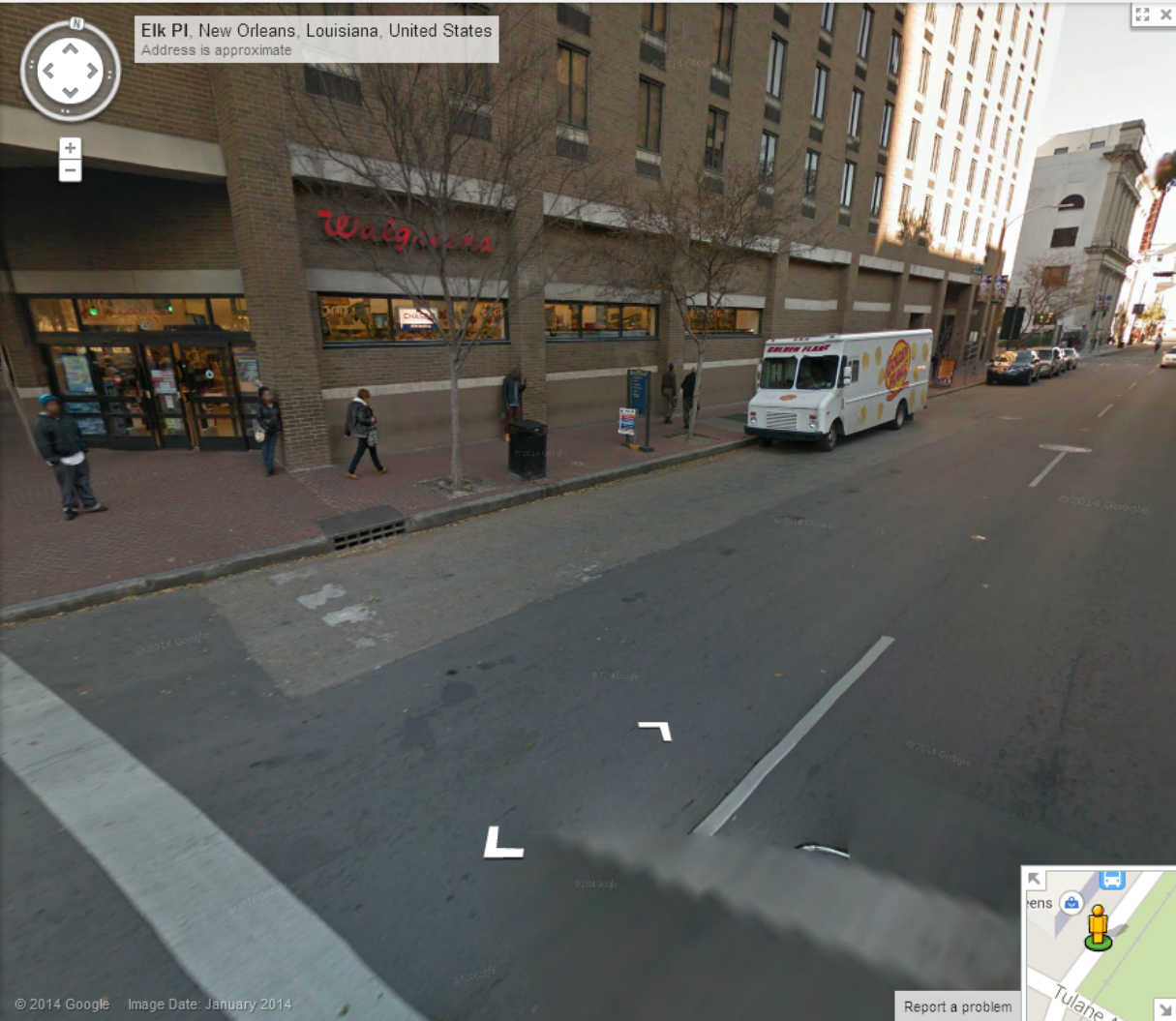

Elk Pl, New Orleans, Louisiana, United States
Address is approximate

© 2014 Google | Image Date: January 2014 | Report a problem

Zone H – S. Rampart at Canal Street

Google from: Southern University, 6400 Press Dr, New Orleans, LA 70126 to: Canal St & S Sign in

Get directions My places

Car, Bus, Walk, Bike

A Southern University, 6400 Press Dr, New Orleans, LA
B Canal St & S Rampart St, New Orleans, LA
Add Destination - Show options
Leave now 06/19/14 1:35pm **GET DIRECTIONS**

Suggested routes

Walk → Bus 57 → Walk	36 mins
1:55pm - 2:30pm	
Walk → Bus 60 → Bus 64 → Walk	1 hour 1 min
1:36pm - 2:37pm	
Walk → Bus 57 → Walk	36 mins
2:31pm - 3:06pm	
Walk → Bus 57 → Walk	36 mins
2:55pm - 3:30pm	

Transit directions to Canal St & S Rampart St, New Orleans, LA

A Southern University
6400 Press Dr
New Orleans, LA 70126

- Walk to Southern at University (Park 2)
About 1 min (246 ft)

O Southern at University (Park 2) Stop ID: N3467
Bus 57 Bus towards Canal Street via UNO



© 2014 Google. Image Date: January 2014. Report a problem

Zone I – S. Rampart at Canal Street

Google from: Southern University, 6400 Press Dr, New Orleans, LA 70126 to: Canal St & S

A Southern University, 6400 Press Dr, New Orleans, LA

B Canal St & S Rampart St, New Orleans, LA

Add Destination - [Show options](#)

Leave now 06/19/14 1:35pm

Suggested routes

57	36 mins
1:55pm - 2:30pm	
60 64	1 hour 1 min
1:36pm - 2:37pm	
57	36 mins
2:31pm - 3:06pm	
57	36 mins
2:55pm - 3:30pm	

Transit directions to Canal St & S Rampart St, New Orleans, LA

A Southern University
6400 Press Dr
New Orleans, LA 70126

Walk to Southern at University (Park 2)
About 1 min (246 ft)

O Southern at University (Park 2) Stop ID: N3467
 57 Bus towards Canal Street via UNO

S Rampart St, New Orleans, Louisiana, United States
Address is approximate

© 2014 Google Image Date: November 2013

Zone P – Saratoga at Elk Place

Old St Bernard St, New Orleans, ...

https://maps.google.com/maps?ll=29.9994057,-90.0572185&sspn=0.1141805,0.1757992&geocode=Fc...

Veolia Transportation Route Status The National Transit D... SolarOS - Login /localhost:8765/ Monthly Statistics Log In - Confluence Listen Express Amber and Stefan Error Transit Tracker Login

Google from: Southern University, 6400 Press Dr, New Orleans, LA 70126 to: Canal St & S Sign in

Get directions My places

1:50pm - 2:06pm	25 mins
1:52pm - 2:17pm	
2:04pm - 2:26pm	22 mins
2:20pm - 2:36pm	15 mins

Transit directions to Cleveland Ave

- A** Old St Bernard St
New Orleans, LA 70116
 - Walk to St Bernard at N. Prieur
About 4 mins (0.2 mi)
- O** St Bernard at N. Prieur Stop ID: N1128
Bus 52 Bus towards Canal Street via St. Anthony Avenue
1:54pm - 2:06pm (11 mins, 12 stops)
- O** Elk Place at Cleveland
- B** Cleveland Ave

Travel time: about 15 mins

Local agency information:
Contains more information on fares, schedules, and service advisories
New Orleans RTA - (504) 248-3900

These directions are for planning purposes only. You may find that construction projects, traffic, weather, or other events may cause conditions to differ from the map results, and you should plan your route accordingly. You must obey all signs or



© 2014 Google Image Date: January 2014

Report a problem

Color Rendering



THIS DRAWING IS THE PROPERTY OF TOLAR MANUFACTURING COMPANY. IT IS TO BE KEPT IN THE OFFICE OF THE ENGINEER OR ARCHITECT. IT IS NOT TO BE REPRODUCED OR TRANSMITTED IN ANY FORM OR BY ANY MEANS, ELECTRONIC OR MECHANICAL, INCLUDING PHOTOCOPYING, RECORDING, OR BY ANY INFORMATION STORAGE AND RETRIEVAL SYSTEM, WITHOUT THE WRITTEN PERMISSION OF TOLAR MANUFACTURING COMPANY.

ZONE	REV	DESCRIPTION	DATE	APPROVED
	A	SEE ECR# 285	12/10/10	
	B	ADDED MOUNTING DIMS.	7/18/11	VB

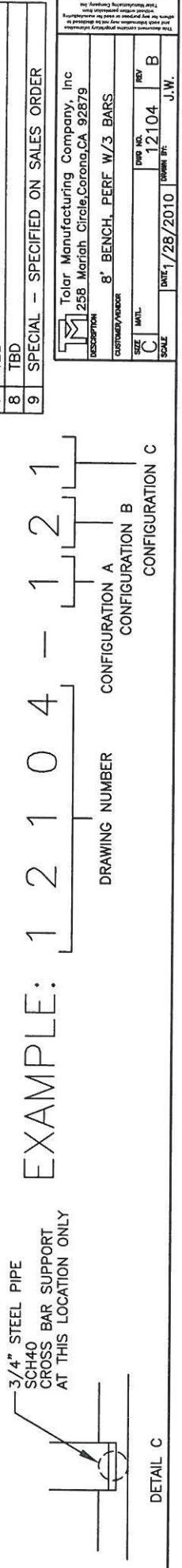
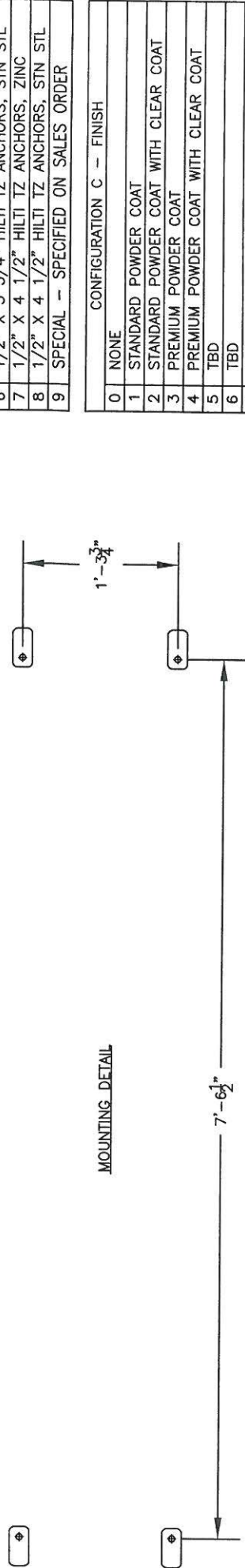
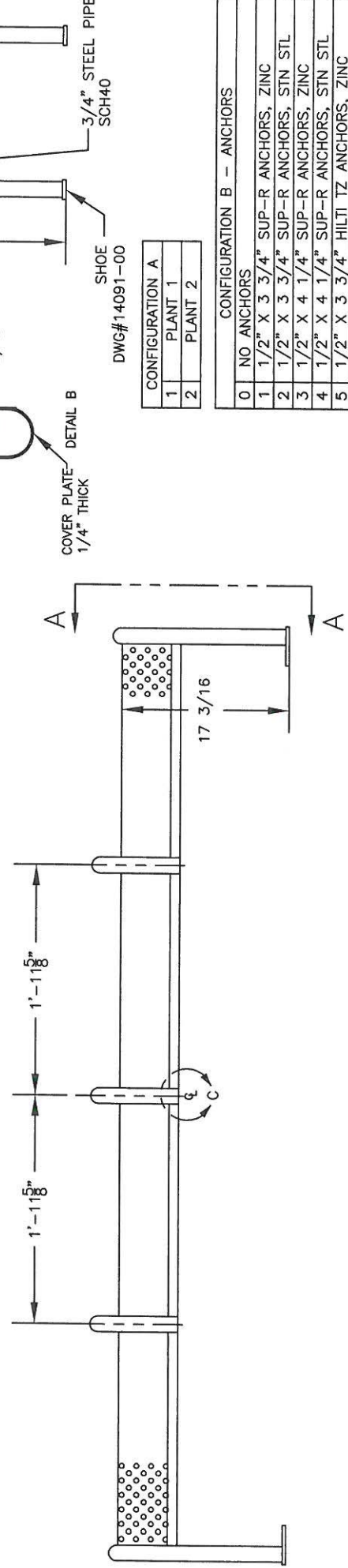
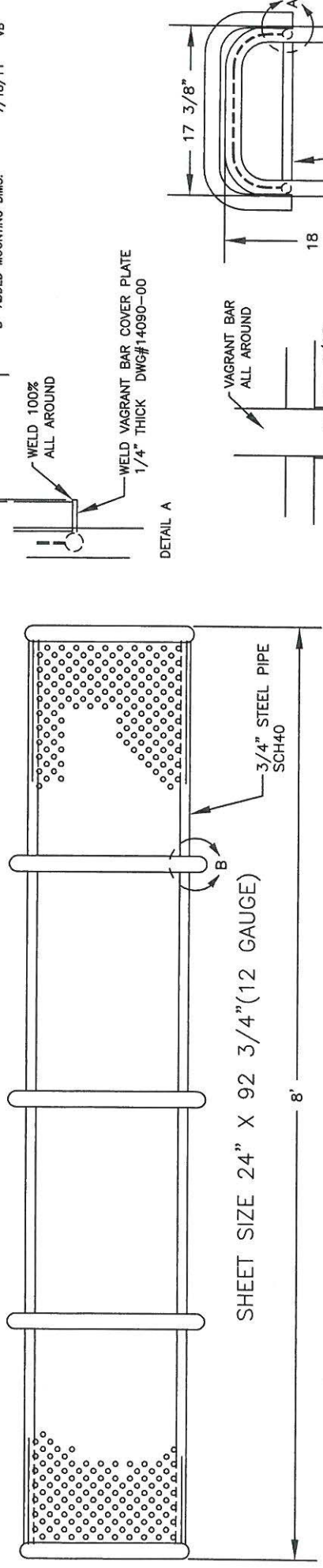

CONFIGURATION A	
1	PLANT 1
2	PLANT 2

CONFIGURATION B - ANCHORS	
0	NO ANCHORS
1	1/2" X 3 3/4" SUP-R ANCHORS, ZINC
2	1/2" X 3 3/4" SUP-R ANCHORS, STN STL
3	1/2" X 4 1/4" SUP-R ANCHORS, ZINC
4	1/2" X 4 1/4" SUP-R ANCHORS, STN STL
5	1/2" X 3 3/4" HILTI TZ ANCHORS, ZINC
6	1/2" X 3 3/4" HILTI TZ ANCHORS, STN STL
7	1/2" X 4 1/2" HILTI TZ ANCHORS, ZINC
8	1/2" X 4 1/2" HILTI TZ ANCHORS, STN STL
9	SPECIAL - SPECIFIED ON SALES ORDER

CONFIGURATION C - FINISH	
0	NONE
1	STANDARD POWDER COAT
2	STANDARD POWDER COAT WITH CLEAR COAT
3	PREMIUM POWDER COAT
4	PREMIUM POWDER COAT WITH CLEAR COAT
5	TBD
6	TBD
7	TBD
8	TBD
9	SPECIAL - SPECIFIED ON SALES ORDER

EXAMPLE: 1 2 1 0 4 - 1 2 1

DRAWING NUMBER

CONFIGURATION A

CONFIGURATION B

CONFIGURATION C

Tolar Manufacturing Company, Inc
 255 Mariah Circle, Corona, CA 92879

DESCRIPTION: 8" BENCH, PERF W/3 BARS

CUSTOMER/ORDER

SIZE: 12.104

REV: B

SCALE: 1/8" = 1'-0"

DATE: 1/28/2010

WORK BY: J.W.

Bench Photos from Streetcar Shelters on Canal Street



Bench Photos from Streetcar Shelters on Canal Street





BUS STOP ZONES

A	62, 63, 64	I	91
B	51, 52	J	100
C	39, 51, 52, 62, 63, 64	K	100
D	84, E2	L	11, 100
E	100, 101, 102, 114, 115	M	10, 16
F	57, 88	N	5, 10, 16, 55
G	100, 101, 102, 114, 115 W2, W3, W8	O	39
H	57, 88, 91	P	39