



CITY OF NEW ORLEANS

Historic District Landmarks Commission

Guidelines for Roofing



ROOFS

A building’s roof provides the first line of defense against the elements while its design greatly affects its overall appearance. Therefore, the following functional and aesthetic concerns should be evaluated when considering new roof construction or roof alteration:

- Weather-tight roofing preserves a building and provides shelter from storm water, wind and sun
- Roofing helps define the building’s character, silhouette and architectural style
- The form, color and texture of the roof and its associated features affect the scale and massing of the building
- Roofing variations add visual interest to the streetscape

SECTION INDEX

The HDLC reviews all roof form modifications, materials, and features that are visible from the street including:

- Roof Forms – Page 05-2
- Roof Materials and Slate – Page 05-3
- Tile – Page 05-4
- Metal – Page 05-5
- Asbestos – Page 05-6
- Asphalt and Flat Roofing Systems – Page 05-7
- Ridge Tiles, Cresting and Finials – Page 05-8
- Ventilation Systems and Chimneys – Page 05-9
- Solar Collectors and Skylights – Page 05-10
- Dormers – Page 05-11
- Gutters and Downspouts – Page 05-12

All applicants must obtain a Certificate of Appropriateness (CofA) as well as all necessary permits prior to proceeding with any work. Please review this information during the early stages of planning your project. Familiarity with this material can assist in moving a project quickly through the approval process, saving applicants both time and money. Staff review of all details is required to ensure proposed work is appropriate to the specific property.

Additional *Guidelines* addressing other historic building topics are available at the HDLC office and on its web site at www.nola.gov. For more information, to clarify whether a proposed project requires Historic District Landmarks Commission (HDLC) review, to obtain property ratings or permit applications, please call the HDLC at (504) 658-7040.

USING THESE GUIDELINES

The first step in using these Guidelines is to understand the rating. The rating corresponds to the historical and/or architectural significance of properties and determines what will be permitted within local Historic Districts or at local Landmarks under the jurisdiction of the HDLC.

- S** *Significant Properties – Retain the highest degree of architectural and historical merit.*
- C** *Contributing Properties – Contribute to the overall District and city character.*
- N** *Non-Contributing Properties – Do not contribute to the overall District character.*

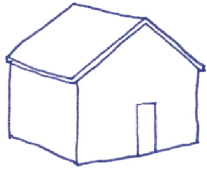

Front Gable

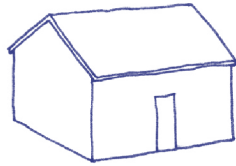

Side Gable

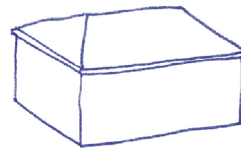

Hipped

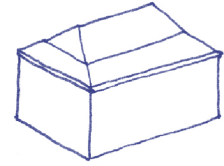

Double Pitched

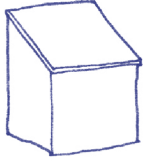

Shed

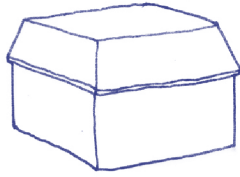

Mansard

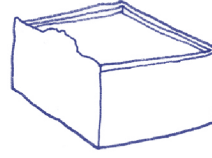

Flat with Parapet

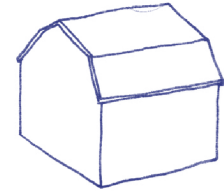

Gambrel

HISTORIC CHARACTER OF ROOF FORMS

The historic form of a roof is critical to the understanding of a building's type and architectural style. Alterations to a roof's shape can have a negative impact on the building's appearance. Roof forms can have various pitches and be combined in different manners to provide numerous roof types. Some of the most common roof forms found in New Orleans are illustrated above.

ROOF PITCH AND MATERIALS

The pitch or slope of a roof helps define the appropriate materials for the roof. Low-pitched to flat roofs depend on a continuous or nearly continuous roof surface to minimize moisture infiltration. Material options for low-pitched roofs include built-up hot tar roofing; roll roofing; and soldered flat seam metal. Possibilities for moderately to steeply sloped roofs include unit materials such as slate, terra cotta, metal and asphalt shingles.

Roof Form, Parapet and Cornice Review

Alterations of roof forms including the addition of dormers without evidence of prior existence



Architectural Review Committee.
Commission Review.
HDLC Staff review.

Minor changes to flat or low-sloped roofs or rear shed addition roofs



HDLC Staff review.

Modify parapets or cornices or install cap flashing



Commission appeal.
HDLC Staff review.

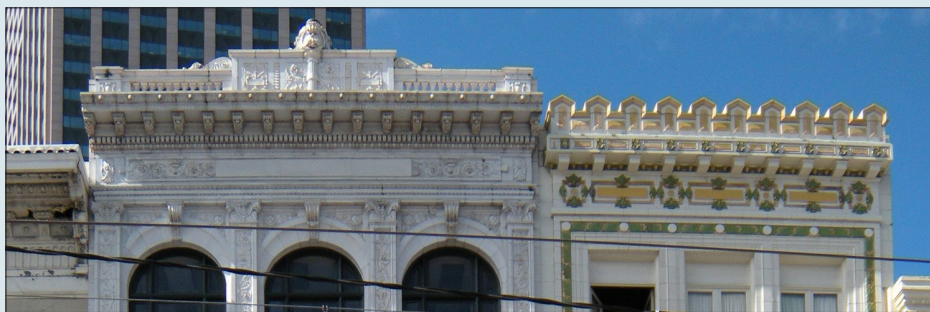

This commercial building row has decorative cornices and parapets at the front elevation with lower flat roofs behind. Retain all historic cornices and parapets.

PARAPETS are the portion of a wall that projects above an adjacent roof surface.

CORNICES are projecting horizontal moldings towards the top of the building wall.



The parapet on this residential gallery features a central arch and conceals the low sloped gable roof beyond. The paired brackets at the cornice are typical of the Italianate style.



This distinctive slate roof with diamond patterns, terra cotta ridge caps, and Chinese caps are being retained as part of the rehabilitation project.

ROOFING MATERIALS

Historically, roofing materials were selected based upon practical and aesthetic criteria, including pitch, weather conditions and availability of materials and craftsmen. Prior to the fires of 1788 and 1794 in the City of New Orleans, roofing was generally wood shingles. Following the fires, roofs were typically replaced and new buildings constructed with terra cotta tiles and later slate.

Each material provides a specific color, texture and pattern to a roof surface. Terra cotta and slate provide a modulated surface with variations in color, shadow lines, texture, veining and thickness. Decorative slate shingles were also used, particularly in the Victorian period during the second half of the nineteenth century, to add additional colors or shapes to roof surfaces.

With industrialization at the end of the 19th century and beginning of the 20th century, new roofing materials were introduced, including metal roofing, asbestos and asphalt based shingles, as well as varieties of rolled or built-up roofing for flat installations. As time progressed, the variety of metal roofing was also expanded to include copper, galvanized sheet steel and aluminum.

More recently, a larger variety of substitute roofing materials intended to simulate historic materials have been developed, with some being more successful than others. These include “dimensional” or “architectural” asphalt-composition shingles; fiberglass, lightweight concrete, metal or recycled rubber shingles intended to evoke the appearance of terra cotta or slate.

SUBSTITUTE MATERIALS

Care is recommended when using substitute materials since they might not have the longevity promised and they can potentially damage historic building fabric.

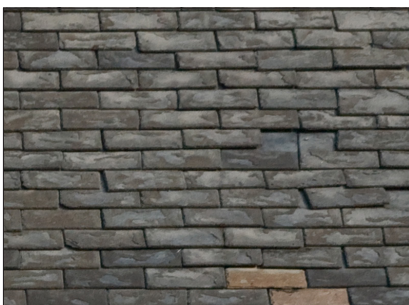

Individual missing or damaged slates can often be replaced, extending the serviceable life of the roof and postponing costly replacement.

SLATE

A slate roof can last 60 to 125 years depending on the roof slope, stone properties, formation, installation quality and regularity of maintenance. A failing slate often slowly delaminates, chips and absorbs moisture, causing the deterioration process to accelerate over time. Problems with slate roofs are typically the result of localized failure since many of the roof accessories and fasteners do not have the same 100-year life span as the slate itself. To extend the serviceable life of a roof, property owners are encouraged to address localized problems as they become apparent, using a qualified slate roofer.

Typical localized problems and possible repairs for slate:

- Loosening or corrosion of fasteners for slate or accessories – *Reattach or replace fastener*
- Split or cracked slate – *Install sheet metal under shingle, fill split or hole with roofing cement*
- Missing or damaged slates or roof accessories – *Replace to match original*

If over 20% of the roof slates are damaged or missing, replacement of the roofing might be warranted, although property owners are strongly encouraged to make every attempt to match decorative patterns and colors with replacement materials. Imitation slate is available in a variety of materials but many have not been available commercially for very long. Dimensional or architectural fiberglass asphalt shingles are manufactured by several companies, simulating the shapes, color and variegated color appearance of slate. Select flashing material that has a life span similar or longer than the new roofing.

Slate Roof Review	
<p>Replace roof in-kind with slate</p> <p>S C N HDLC Staff review.</p>	
<p>Install new slate roof</p> <p>S C N HDLC Staff review.</p>	
<p>Remove slate roof and install other roof material</p> <p>S C Commission appeal.</p> <p>N HDLC Staff review.</p>	



This concrete tile roof includes a finial and terra cotta ridge caps at the top of the main roof and along the roof hip.

TILE

A tile roof, which includes terra cotta and concrete tiles, can last over 100 years depending on the material's properties and manufacturing process, installation quality and regularity of maintenance. Similar to slate, problems with tile roofs are typically the result of localized failure since many of the roof accessories and fasteners do not have the same 100-year life span as the tile itself. In addition, the tiles are relatively fragile and susceptible to damage from falling tree limbs and other impacts. To extend the serviceable life of a roof, property owners are encouraged to address localized problems as they become apparent, using a qualified roofer.

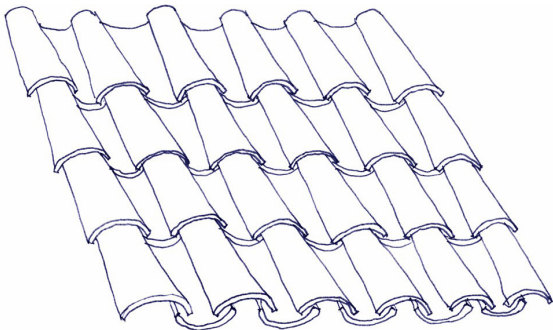

Terra cotta tile provides a durable, fire resistant and distinctive roof finish. Spanish tiles are rounded and installed in an overlapping pattern.

Typical localized problems and possible repairs for tile roofing:

- Loosening or corrosion of fasteners for tiles or accessories – *Reattach or replace fastener*
- Cracked tile – *Install sheet metal under tile, fill split or reattach dislodged piece with tinted roofing cement*
- Missing or damaged tile or roof accessories – *Replace to match original, preferably with salvaged units with the same dimensions and similar visual characteristics*

If over 20% of the tiles on a roof slope is damaged or missing, replacement of the roofing might be warranted, although property owners are strongly encouraged to make every attempt to match decorative shapes, patterns and colors with replacement materials. Other materials are used to simulate terra cotta, concrete or other tiles, but many do not have the same dimensional characteristics of the historic material or have not been available commercially for very long. It is often possible to reuse salvaged tiles taking care to verify availability of appropriate quantities of needed sizes, shapes and colors. **The HDLC does not approve red asphalt shingles as an alternative to terra cotta tile replacement.** When replacing a roof, select flashing material that has a life span similar or longer than the roofing.

Terra Cotta, Concrete and Tile Roof Review

Replace roof in-kind to match historic roofing

S C N HDLC Staff review.

Install new tile roof

S C N HDLC Staff review.

Remove historic tile roof and install other roof material

S C Commission appeal.
N HDLC Staff review.



The top of this church tower includes a standing seam copper roof, copper finials and a weathervane. Copper roofing is known for its longevity with relatively little required maintenance.

METAL ROOFING COLOR

Metal roof colors in New Orleans tend to be natural metal or natural copper, or if a painted finish is desired, colors that are similar to metal, such as silver to grey or muted green. In the region, red metal roofs are more commonly found in agricultural settings and are generally not appropriate within the City. **The HDLC Staff provides final approval for metal roofing colors.**

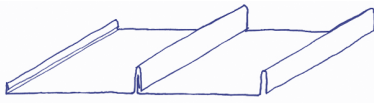

Standing Seam

Approved for all building types

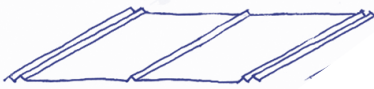

5-V Crimp

Approved only for sheds, garages and some residential

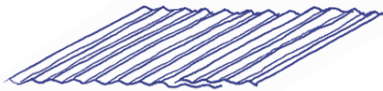

Corrugated

Approved only for shed, garage, commercial, overhangs



R-Panel

Approved only for Non-Contributing commercial



Rib-Panel

Approved only for Non-Contributing commercial

METAL

Metal was popularized for roofing after sheet metal production was expanded following the mid 19th century, and can be found on commercial and industrial buildings, as well as residences and outbuildings. Traditional sheet roofing metals include lead, copper, zinc, tin plate, tern plate and galvanized iron. Many metal roofs require regular painting with traditional colors including silver, grey or green to minimize the potential for corrosion.

On shallow pitch roofs like galleries, porches, cupolas or domes, small rectangular pieces of flat seam metal roofing were installed with edges crimped together and soldered to form a weather-tight surface. On steeper pitched roofs, long continuous seams were used, typically in a standing seam configuration, providing regular ridges down roof slopes. Corrugated or other paneled metal roofing was also common on commercial and industrial buildings as well as outbuildings, such as sheds and garages.

Deterioration of the metal surface tends to occur from wearing of the protective painted or galvanized surface, chemical action, rusting, pitting or streaking, airborne pollutants, rain or material acids, or galvanic action. Galvanic action occurs when dissimilar metals chemically react against each other and corrode, and can come from adjacent metals, such as fasteners and non-adjacent metals, such as roof cresting via rainwater.

If the roof is generally rusting, splitting, pitted, severely buckled or warped, or many of the seams or edges are open or disfigured, replacement of the roofing might be warranted. If considering replacement, applicants are encouraged to make every attempt to match seam patterns

and color with the replacement material. Not all types of metal roofing are appropriate at all building types and styles. In addition, the installation should not negatively impact a building's style or detailing. Special attention should be paid to ensure sympathetic edge conditions including eaves, ridges, parapets and flashings.

Typical localized problems and possible repairs for metal:

- Worn paint, galvanizing or coating – *Repaint*
- Slipping sheet, panel, open seam or solder joint – *Refasten and/or re-solder*
- Isolated rusting or holes – *Replace to match original*

Metal Roof Review	
Metal roofs are typically not appropriate for highly visible roof slopes or where the historic roofing material would have been slate, especially on high-style buildings. Metal roofs may be considered for installation where minimally visible.	
Replace in-kind with metal roof material of same material and design	
S C N	HDLC Staff review.
Replace copper roof with other material	
S C N	Commission appeal.
Install standing seam metal roofing when appropriate for building type and style	
S	Commission review.
C N	HDLC Staff review.
Install corrugated metal roofing at sheds, garages, commercial buildings	
S C N	HDLC Staff review.
Install 5-V crimp when appropriate for building type and style	
S	Commission review.
C N	HDLC Staff review.
Install Rib Panel or R-Panel at non-commercial buildings	
S C N	Commission appeal.
Remove metal roofing and install other material	
S	Commission appeal.
C N	HDLC Staff review.



The asbestos shingle roof has terra cotta caps on the ridge and hips and a triangular louvered vent at the front gable. The ridge caps and louvered vents should be retained. Gutter installation is recommended.

ASBESTOS

Asbestos became a popular roofing material at the beginning of the 20th century. Asbestos roofing is made from asbestos mineral fibers and either Portland or hydraulic cement and it provides a durable, lightweight, economical, fireproof, rot and termite resistant alternative to slate, terra cotta and corrugated metal roofing.

With appropriate maintenance an asbestos shingle roof can be expected to last well over 30 years, with cracking and rusting nails being the most typical cause of failure.

Although the manufacturing of asbestos roofing essentially ceased when asbestos was banned by the EPA in 1973, the HDLC encourages the retention of existing asbestos roofing that continues to provide a watertight roof surface. If the roofing is damaged, consultation with a professional to determine whether repair is feasible is recommended. It should also be noted that asbestos roofing is often available at architectural salvage suppliers.

Typical localized problems and possible repairs for asbestos shingles:

- Split or puncture – *Install sheet metal under shingle, fill split or hole with grout of Portland cement and water*
- Loosening or corrosion of fasteners for asbestos shingle or accessories – *Reattach or replace fastener*
- Moss or fungi on surface – *Trim back adjacent trees allowing sun to dry out roof surface*
- Missing or damaged shingles or roof accessories – *Replace shingles with non-asbestos shingles to match original and roof accessories in-kind*

If over 20% of the asbestos shingles on a roof slope are damaged or missing, replacement of the roofing might be warranted. Property owners are encouraged to consider installing salvaged asbestos roofing or non-asbestos fiber-cement products that visually duplicate traditional asbestos tiles. Other alternative roofing materials are hard roofs, such as slate, terra cotta, metal or simulated slate or terra cotta.

REPAIR AND REMOVAL OF ASBESTOS SHINGLE

Great care should be taken when working with broken asbestos products and during its removal. It is recommended that all asbestos related work be undertaken by a licensed contractor.

Property owners are responsible for ensuring that all asbestos removal and disposal is handled in accordance with all applicable regulations and procedures.



The asbestos roof has some non-asbestos replacement shingles of a similar size and shape as the existing roofing.

Asbestos / Simulated Slate Roof Review

Replace asbestos / simulated slate roof with slate, imitation slate “architectural” or “dimensional” asphalt or metal material

S C N

HDLC Staff review.

Remove asbestos /simulated slate roof and install other roof material

S C

Commission appeal.

N

HDLC Staff review.

ASPHALT SHINGLE AND SIMULATED SLATE ROOFING COLOR

The colors for asphalt shingle and simulated slate roofs in New Orleans should simulate the appearance of slate. This typically will include a range of grays. Brown shingles, which simulate wood, are not appropriate in New Orleans. Applicants are not encouraged to install decorative color patterns or shaped shingles in replacement roof installations.

HDLC Staff provides final approval for asphalt shingle and simulated slate roofing colors.



This dimensional asphalt shingle hipped roof features ridge tiles at the hips and a perimeter gutter.

ASPHALT





Asphalt became a popular roofing material at the beginning of the 20th century providing a relatively inexpensive and easily installed roofing material. Early roofing was generally made of asphalt-saturated felts in a variety of shapes, styles, textures and colors. Today, asphalt shingles are made with fiberglass, generally as 3-tab, “architectural” or “dimensional” shingles, which include multiple layers of material with simulated shadows suggesting wood or slate.

An asphalt shingle roof can be expected to last from 15 to 25 years with “architectural” or “dimensional” shingles lasting longer due to their multiple layers. Over time, asphalt shingles can curl, lose their mineral coating, be dislodged by wind or become brittle.

Typical localized problems and possible repairs for asphalt:

- Split or puncture – *Install sheet metal under shingle, fill split or hole with roofing cement*
- Moss or fungi on surface – *Trim back adjacent trees allowing sun to dry out roof surface*
- Missing or damaged shingles or roof accessories – *Replace to match original*

If over 20% of the asphalt shingles on a roof slope are damaged or missing, replacement of the roofing might be warranted.

Asphalt Roof Review	
Replace existing asphalt roof in kind	 HDLC Staff review.
Replace existing 3-tab asphalt roof with new “dimensional” or “architectural” asphalt shingles to simulate slate	 HDLC Staff review.
Remove “dimensional” or “architectural” asphalt shingles and install 3-tab asphalt roofing	 Commission appeal.  HDLC Staff review.

FLAT ROOFING SYSTEMS

Although very few roofs are truly “flat”, low-sloped, generally defined as a pitch below 3:12 slope, (3” rise for 12” run), require a watertight roofing system. There are a variety of flat or low-slope roof systems including: metal roofing; built-up roofing, single-ply roofing, and modified bitumen roofing.

By contrast steeper pitched roof systems generally employ shingles; in materials such as slate, terra cotta and asphalt; to shed storm water.

Typical localized problems for flat roofs include:

- Splits, punctures, or cracking of surface
- Standing water or poor drainage

In selecting the most appropriate roofing material it is important to verify that the design addresses the building’s drainage and specific details of the existing conditions including attachment, substrate and weight limitations. Other factors include maintenance requirements, anticipated life span in New Orleans’ climate and hurricane resistance.

Flat or Low-Sloped Roof Review
Install new flat or low-sloped roof visible from a public right of way
 HDLC Staff review.



A flat or low-sloped roof is located behind the parapet and bracketed cornice.



Ridge caps are located along the roof hips, cresting is along the top ridge and a finial is found at the end of the main roof gable. Chimney placement reflects the internal organization of the residence and Chinese caps provide roof ventilation.

ROOF FEATURES

Roof features are decorative and sometimes functional elements that help define the profile of a roof against the skyline and should complement the building’s style. Historic rooftop features include ridge caps, cresting, finials, roof vents, flashing, gutters, downspouts, chimneys, dormers, bell towers, turrets and monitors. More recent additions include skylights, mechanical and television equipment and solar panels.

Ridge tiles, cresting and finials can be found on a variety of building types and styles in New Orleans, and more specifically on sloped slate, terra cotta, asbestos and asphalt roofs. They are visually important features, accentuating the changes in roof slopes, and the HDLC encourages their retention. Most prevalent are those made from terra cotta, in either overlapping barrel forms or in an English-V mortared between joints. In addition, ceramic and cast iron versions are also still extant. Ridge caps are typically located along a top ridge or hip of a roof, and cover the intersection where two roof slopes meet. Cresting is similarly located to ridge caps, but its location tends to be limited to the upper portions of a roof. Finials are often found at the end of a gable roof form or dormer.

English V - With mortar joints

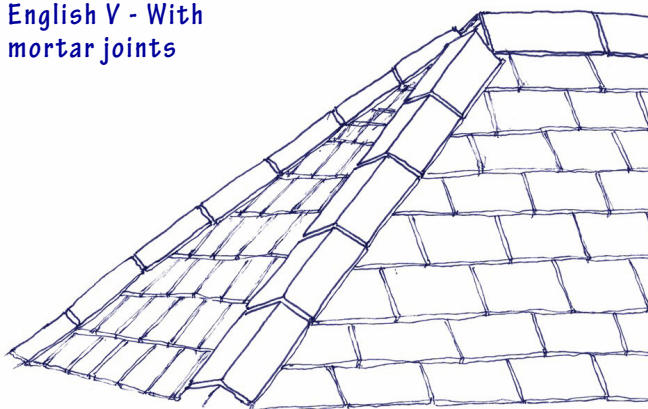

Spanish Tiles - With overlapping joints

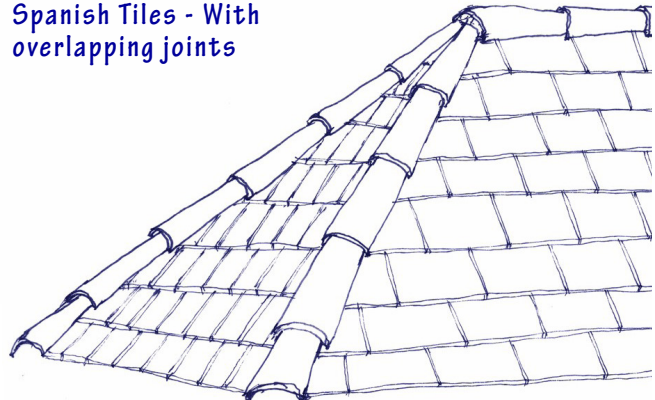

Ridge tiles in New Orleans are often in an English-V profile with mortar between adjoining tiles as seen in the top drawing or in overlapping Spanish tiles as seen below.

Ridge Tile, Cresting and Finial Review	
Install ridge tiles, cresting or finials	
S C N	HDLC Staff review.
Remove ridge tiles, cresting or finials	
S C	Commission appeal.
N	HDLC Staff review.
Remove ridge tiles, cresting or finials for the installation of an appropriate standing seam metal roof	
S	Commission review.
C N	HDLC Staff review.

Roof ventilation systems are generally located along or on the roof ridge and can greatly reduce the heat in an attic and home in the summer months.



Chinese Cap
Most appropriate for all buildings in Historic Districts



Turbine Ventilator
Not appropriate – Can only be installed as a replacement in-kind



Power Roof Vent
Approved only in less visible locations



Ridge Vent
Approved only where ridge tiles are not present

In addition to ventilation systems, residential roof penetrations will typically include plumbing vents and could include kitchen and laundry vents. To minimize the visual impact of roof vents, they should be placed in an orderly fashion below the roof ridge. Any roof or wall vent 4" diameter or larger is subject to HDLC review. (Refer to *Guidelines for Commercial Buildings, Page 11-21* for roof-mounted building equipment.

Roof Ventilation Systems Review	
Install Chinese caps, replacement in-kind of turbine ventilators, power roof vents, ridge vents	S C N HDLC Staff review.
Install turbine ventilators, highly visible power roof vents or ridge vents in place of ridge tiles	S C N Commission review.
Install roof vents or systems 4" in diameter or larger that are visible from the street	S Commission review. C N HDLC Staff review.

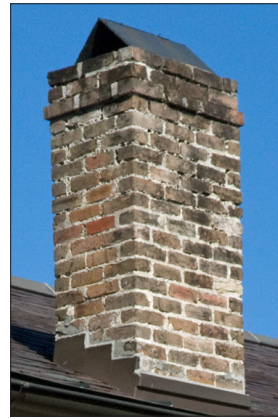

An inverted "V" cap is at the top of the chimney and flashing at its base.

Chimneys were typically designed to complement the style of a building and period of construction. In New Orleans, most are constructed of brick, some of which have been covered by stucco or plaster, and they are most often located within the building walls rather than be attached to an exterior wall. The rhythm and placement of chimneys typically reflect the internal organization of a building and represent an important building feature.

Most building types and styles, including shotguns and colonial revival buildings, tend towards square or rectangular chimney shafts, sometimes with molded tops, are often covered with inverted "V" shaped caps. Victorian period chimneys can include decorative detailing including corbelling, varied patterns, undulating and molded surfaces and decorative terra-cotta chimney pots. **Removal of historic chimneys is only approved by the HDLC if they are structurally deficient.** The visibility of new chimney flues should be minimized, and new flues can generally be clad in brick or stucco.



This row of three chimneys suggests the division of rooms on the interior of the building. The central chimney includes an inverted "V" cap and English V ridge tiles with mortared joints marking the top of the roof.

Chimney Review	
Remove structurally deficient chimney or installation of visually unobtrusive chimney	S Commission review. C N HDLC Staff review.
Remove or install all other chimneys	S C Commission appeal. N HDLC Staff review.



Satellite dishes should be installed towards the rear of the building so they are minimally visible from the street.

Solar collectors provide a renewable energy source. The City of New Orleans encourages solar collectors for space heating, hot water and electricity. However in Historic Districts, property owners are encouraged to locate solar collectors where they are minimally visible or hidden from public view. **Solar collectors shall be located as far back from the front of the building wall as possible, and a minimum of 10'-0" from the front building wall.** When visible, the HDLC recommends using products and installation methods that allow the panels to blend with their surroundings. Examples include the use of black panels on black mounts, rectangular array configurations and thin film panels installed on standing seam metal roofs. On Significant buildings and corner properties, it might be more appropriate to locate solar collectors on the ground in the rear yard.



Some skylights were historically located in warehouse and commercial buildings, providing natural interior light and ventilation. The visibility of new skylights should be minimized.

Skylights are sometimes historically found in commercial buildings. They are occasionally appropriate in sloped roof building types and townhouses where dormer windows are not present. **Property owners are encouraged to select skylights that do not extend more than 8" above the roof surface; minimize the overall number; locate skylights a minimum of 10'-0" back from the front building wall, and 12" below the roof ridge, in unobtrusive locations, arranged in an orderly fashion.** The installation should minimize alteration of the roof structure with the long dimension oriented down the roof slope.

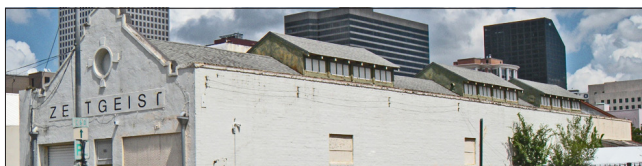

Roof monitors are more typically found on commercial buildings and often provide interior light and ventilation.

Roof monitors are structures that project up from the roof, used for ventilation with louvers, or for light or lookouts with windows. Monitors are often found on warehouse buildings. Property owners are encouraged to retain historic roof monitors.

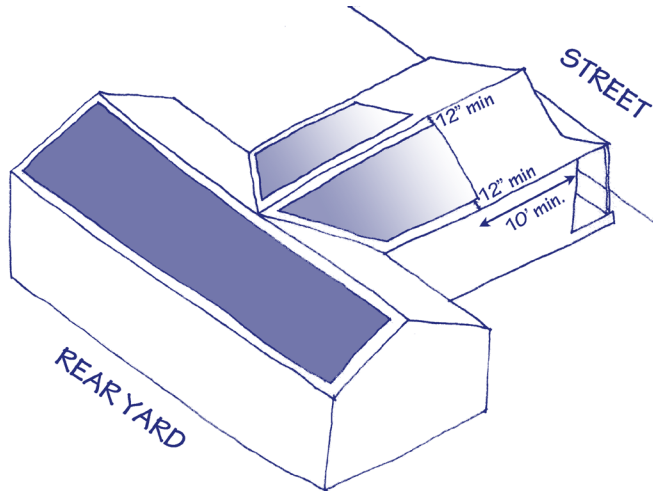

Roof Mounted Equipment, Solar Collector and Skylight Review

Refer to *Equipment and Systems, Guidelines for Site Elements*, page 10-8 for additional requirements

Install roof mounted solar collectors on side and rear roof slopes if they meet the following criteria:

- Set back a minimum of 10'-0" from the front façade
- Less than 8" above the roof surface
- Minimum 12" from roof eave and ridge
- Rectangular and contiguous arrangement when visually prominent
- Low profile, black racking and frame system
- Rails do not extend more than 3" past panel
- Low contrast panels
- Minimally visible conduit painted to match wall color

S

Commission review.

C N

HDLC Staff review.

Install unobtrusive roof mounted equipment or skylight - Minimum 10'-0" from front façade, less than 8" above the roof surface:

S

Commission review.

C N

HDLC Staff review.

Install new visually obtrusive roof mounted equipment or skylight

S C

Commission review.

N

HDLC Staff review.

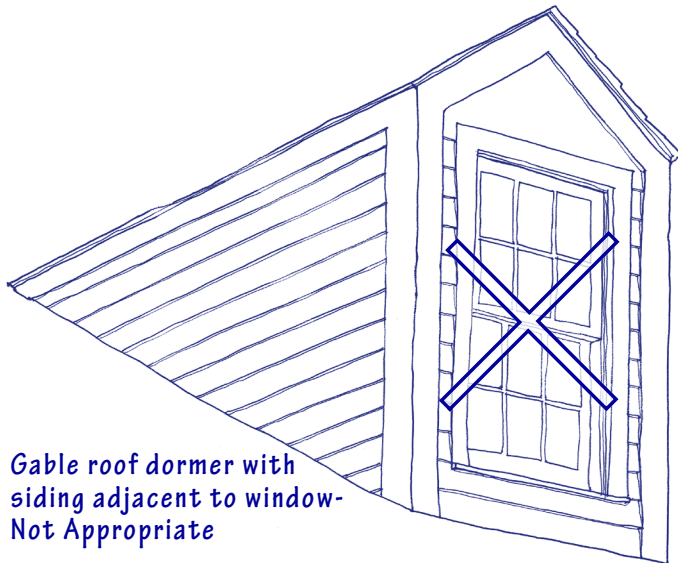

Gable roof dormer with siding adjacent to window- Not Appropriate

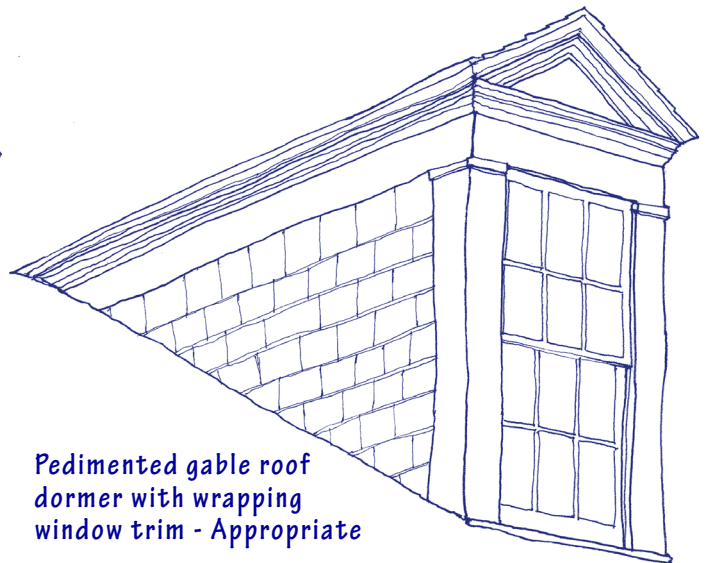

Pedimented gable roof dormer with wrapping window trim - Appropriate

Both gable roof dormers have 6/6 double hung windows. However, the dormer to the left has simple wood trim along the eaves and rakes, with siding flanking the window at the face of the dormer and is inappropriate. The more traditional example at the right is more appropriate with a pedimented gable end with trim framing the window and wrapping to meet the slate at the cheek walls.

Dormers, also known as dormer windows, protrude from the roof surface with a window providing light and additional headroom under roof eaves. Dormers can have various roof shapes but are typically gables. Property owners are encouraged to retain existing historic dormers and reconstruct dormers on buildings where there is clear evidence that they existed. Evidence can be historic photographs indicating a dormer or visible within attic roof framing.

New dormers at historic buildings are not always appropriate. Certain building types and architectural styles did not traditionally include dormer windows. (Refer to *Building Types and Architectural Styles*.) For those buildings that historically included dormers, they were often located on certain roof slopes; set back a certain distance from the roof eave; centered or evenly spaced relative to architectural features below; had a standard form, most often a gable roof form; with window types and styles similar to the remainder of the building; and trim complementing the building’s architectural style.

When considering a new dormer, particularly at historic buildings, property owners are encouraged to consider comparable buildings of the same style and period including the location, form, spacing, dimensions, proportions, style and detailing. For example, dormers are not typically appropriate on side elevation roof slopes. Similarly, oversized dormers to accommodate egress windows or to capture additional interior square footage are often inappropriate.

Cheek wall cladding materials vary with building materials. **On masonry buildings, dormer cheek walls should be slate unless the roof is metal, in which case they can be metal. On wood frame buildings, dormer cheek walls can be slate, wood or cementitious clapboard siding.**



This gable roof dormer is appropriately located, proportioned and detailed for the building and include slate cheek walls. Spanish tile ridge caps should be retained.

Dormer Review	
<p>Reconstruct previously existing dormer – Must provide evidence of previous dormer, scaled elevations, sections and detail drawings:</p> <p>S C N HDLC Staff review.</p>	
<p>Install new dormer – Must provide scaled elevations, sections and detail drawings</p> <p>S C N Commission review.</p> <p>N HDLC Staff review.</p>	

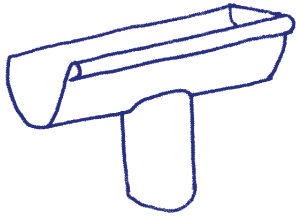

Half-Round Gutter,
Round Downspout
Preferred

K-Style Gutter,
Corrugated Downspout

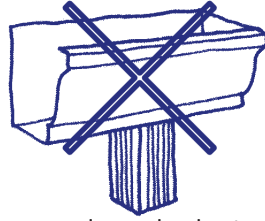

Gutters are typically located near or along the bottom edge of a roof slope to collect rainwater. Although many New Orleans buildings were not designed with gutters, installing them can significantly reduce the water damage to building walls, foundations and piers. Built-in gutters are hidden from view from the ground within or behind architectural features such as cornices or parapets. Pole gutters are located near the bottom edge of a roof slope and project perpendicularly to the roof surface. Both built-in gutters and pole gutters are formed of flashing materials typically wrapped around or within wood forms.

Hanging gutters are located just under the roof slope edge and are usually metal with a half-round or profiled cross sections. Gutter materials have different life spans. Generally, copper has the longest potential life span, followed by steel, with aluminum being highly susceptible to punctures, tears, dents and galvanic reaction to other metals. Vinyl can become brittle and fracture in low temperatures. When installing or reinstalling gutters, property owners should reproduce any special molding, strap or bracket used to support or attach a gutter to a building and repair or replace wood eave detailing and trim. Refer to *Guidelines for Exterior Woodwork* for additional information.



Decorative cast iron boots should be retained.

Downspouts, also known as rainwater conductors, are generally surface mounted to a building's exterior to conduct a gutter's water down the face of the building to the ground or an underground drainage system via a cast iron boot. Similar to gutters, downspouts can be fabricated of copper, galvanized metal, aluminum and vinyl with similar characteristics, in a round or rectangular profile. When adding downspouts to a structure for the first time, they should be arranged in an orderly fashion and mounted to the building rather than to galleries or porches.

KEEP IN MIND...

- Roofing work is potentially dangerous and should be left to professionals
- All roofers are not experienced in all materials, obtain references and verify that roofers have appropriately completed comparable work
- Verify the extent of both the material and installation warranties and company histories
- Verify whether removal of existing roofing is required before installation of new roofing; too much weight can damage structural elements
- Use appropriate fasteners for New Orleans' hurricane-strength winds
- Inspect attics periodically after a storm to catch small leaks early to minimize the potential for interior damage
- Verify the condition of underlying materials for rot or decay and make necessary repairs, including the sheathing or lath, and structural elements
- Install gutters and downspouts while maintaining the existing eave conditions and clean them regularly, typically every spring and fall

Gutter and Downspout Review

Replace gutters in kind; or install k-style or half-round gutters where they do not exist



HDLC Staff review.

Install K-style gutters or gutters with built-in leaf and debris covers



Commission appeal.

HDLC Staff review.

This material is based upon work assisted by a grant from the Department of the Interior, National Park Service. Any opinions, findings, and conclusions or recommendations expressed in this material are those of the authors and do not necessarily reflect the views of the Department of the Interior.

© 2019, City of New Orleans, Louisiana

Prepared by Dominique M. Hawkins, AIA, LEED AP of Preservation Design Partnership, LLC in Philadelphia, PA.